

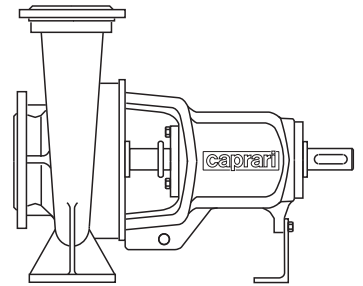

NORM SINGLE-STAGE
PUMPS -EN733 (DIN 24255)
*НОРМАЛИЗОВАННЫЕ НАСОСЫ С
1 РАБОЧИМ КОЛЕСОМ - EN733 (DIN 24255)*
POMPE MONOGIRANTI
NORMALIZZATE - EN733 (DIN24255)

NCD



caprari

pumping power



• Technical data <i>Технические данные</i> Dati tecnici	3
• Pump coding <i>Пояснения к обозначениям</i> Esemplificazione sigla	4
• Performance ranges <i>Диапазон рабочих параметров</i> Campi di prestazione	5
• Operating limits <i>Рабочий диапазон</i> Limiti di funzionamento	6
• Pump construction and materials <i>Конструкция и материалы насоса</i> Costruzione pompa e materiali	7
• Technical data standardized enclosed electric motors - 50Hz <i>Технические данные закрытых электродвигателей - 50Гц</i> Dati tecnici motore elettrico chiuso normalizzato - 50Hz	8
• Performances curves at 1450 n [min-1] <i>Рабочие характеристики при 1450 об. [мин-1]</i> Caratteristiche di funzionamento a 1450 n [min-1]	9
• Performances curves at 1750 n [min-1] <i>Рабочие характеристики при 1750 об. [мин-1]</i> Caratteristiche di funzionamento a 1750 n [min-1]	40
• Performances curves at 2900 n [min-1] <i>Рабочие характеристики при 2900 об. [мин-1]</i> Caratteristiche di funzionamento a 2900 n [min-1]	69
• Performances curves at 3450 n [min-1] <i>Рабочие характеристики при 3450 об. [мин-1]</i> Caratteristiche di funzionamento a 3450 n [min-1]	91
• Overall dimensions and weights <i>Общие габариты и вес</i> Dimensioni di ingombro e pesi	113
• Selection - Dimensions and weights for base mounted electric pumps 2P / 50Hz <i>Подбор - Габариты и вес электронасосов на раме 2P / 50Hz</i> Selezione - Dimensioni e pesi elettropompe su base 2P / 50Hz	115
• Selection - Dimensions and weights for base mounted electric pumps 2P / 60Hz <i>Подбор - Габариты и вес электронасосов на раме 2P / 60Hz</i> Selezione - Dimensioni e pesi elettropompe su base 2P / 60Hz	116
• Selection - Dimensions and weights for base mounted electric pumps 4P / 50Hz <i>Подбор - Габариты и вес электронасосов на раме 4P / 50Hz</i> Selezione - Dimensioni e pesi elettropompe su base 4P / 50Hz	117
• Selection - Dimensions and weights for base mounted electric pumps 4P / 60Hz <i>Подбор - Габариты и вес электронасосов на раме 4P / 60Hz</i> Selezione - Dimensioni e pesi elettropompe su base 4P / 60Hz	118
Flanges (UNI EN 1092-2) - <i>Фланцы (UNI EN 1092-2)</i> - Flange (UNI EN 1092-2)	119

GENERAL INFORMATION

Single-stage horizontal shaft pumps with main dimensions and characteristics conforming to EN733 (DIN 24255) standards.

- Pump casing:
volute type with flanged delivery port.
- Impeller:
high efficiency closed type with balanced axial thrust.
Available in either cast iron or bronze.
- Shaft and supports:
the AISI 430 stainless steel shaft (fully protected against contact with the pumped water) is guided and supported by two ball bearings housed in the connecting support that are permanently lubricated with high quality grease to guarantee longer life.
- Seal:
the mechanical type, housed in the connecting support and easily replaceable.
- Coupling to the motor
the NCD series pumps can be coupled to IP 55 standard electric motors with B3 motor mounting. The pumps can be coupled to high-efficiency motors. The BACK PULL OUT constructional concept, connection to the motor with a flexible coupling and spacer, available on request, allow the wet end to be disassembled from the rear for inspection purposes and repairs without disconnecting the motor or the pump casing from the piping.
- Direction of rotation:
clockwise viewed from drive side.
- Port positioning:
axial for suction / radial delivery port pointing upwards.

APPLICATIONS

The NCD series standardized pumps have been designed for several applications, such as firefighting, industrial water supply, industrial uses, anti-frost protection, irrigation, medium and large heating and air conditioning systems and water supply for both civil and industrial uses.

LIMITS

- Max. temperature of pumped liquid: +90°C (special versions on request +140°C)
- Min. temperature of pumped liquid: -10°C.
- Max operating time with closed discharge and liquid at 90°C: 30 sec.
- Nominal pressure 10/16 bar (with flanging conforming to UNI 2223 PN16/PN25).
- The pumps can operate with all fluids chemically and mechanically compatible with the pump materials.

Special versions can be supplied on request.

ХАРАКТЕРИСТИКИ

Одноступенчатые насосы с горизонтальной осью, основные характеристики и размеры которых соответствуют стандартам EN733 (DIN 24255).

- Корпус насоса:
спиральный с фланцевым нагнетательным патрубком.
- Рабочее колесо:
закрытого типа с высоким КПД, с уравновешиванием осевой силы. Доступно в исполнении из чугуна или бронзы.
- Вал и опоры:
вал из нержавеющей стали AISI 430 (полностью защищенный от контакта с перекачиваемой водой) направляется и поддерживается двумя шариковыми подшипниками, размещенными в соединительной опоре и смазанными высококачественной постоянной смазкой, что гарантирует более длительный срок службы.
- Уплотнение:
механического типа, размещенное в соединительном держателе и легко заменяемое.
- Соединение с двигателем
насосы серии NCD могут соединяться со стандартными электродвигателями IP 55 в конструкции В3; насосы могут соединяться с двигателями высокой эффективности. Конструкция BACK PULL OUT и соединение с двигателем с помощью эластичного соединения и распорного дистанционного элемента под заказ позволяют демонтировать заднюю часть гидравлической системы для осмотра или ремонта, не отсоединяя двигатель и корпус насоса от трубопроводов.
- Направление вращения:
по часовой стрелке, если смотреть со стороны электрощитка.
- Ориентация патрубков:
всасывающий - осевая / напорный - радиальная, с направлением вверх.

ПРИМЕНЕНИЕ

Нормализованные насосы серии NCD были разработаны для таких областей применения, как противопожарная защита, водопроводы, промышленность, защита от обледенения, орошение, средние и крупные системы отопления и кондиционирования, а также водоснабжение как для гражданского, так и для промышленного использования.

ОГРАНИЧЕНИЯ ПРИМЕНЕНИЯ

- Максимальная температура перекачиваемой жидкости: +90°C (в спец. исполнениях по запросу: +140°C)
- Минимальная температура перекачиваемой жидкости: -10°C
- Максимальное время работы при закрытом патрубке с жидкостью температурой 90°C: 30 сек.
- Номинальное давление 10/16 бар (с фланцами согласно UNI 2223 PN16/PN25)
- Возможность перекачки всех жидкостей, химически и механически совместимых с конструкционными материалами насосов.

Под заказ могут быть изготовлены специальные исполнения.

CARATTERISTICHE

Pompe monogiranti ad asse orizzontale con caratteristiche e dimensioni principali secondo le norme EN733 (DIN 24255).

- Corpo pompa:
del tipo a voluta con bocca premente flangiata.
- Girante:
del tipo chiuso ad elevato rendimento, con equilibratura della spinta assiale.
Disponibile in ghisa o bronzo.
- Albero e supporti:
l'albero in acciaio inossidabile AISI 430, (totalmente protetto dal contatto con l'acqua pompata) è guidato e sostenuto da due cuscinetti a sfere alloggiati nel supporto di collegamento e lubrificati a grasso permanente di alta qualità a garanzia di una più lunga durata.
- Tenuta:
di tipo meccanico alloggiata nel supporto di collegamento e facilmente sostituibile.
- Accoppiamento al motore
le pompe serie NCD, possono essere accoppiate a motori elettrici standard IP 55 in forma costruttiva B3; le pompe possono essere accoppiate a motori ad alto rendimento.
Il concetto costruttivo BACK PULL OUT e l'accoppiamento al motore con giunto elastico e distanziale spaziatore su richiesta consentono lo smontaggio posteriore della parte idraulica per l'ispezione o la riparazione, senza sconnettere il motore ed il corpo pompa dalle tubazioni.
- Senso di rotazione:
orario visto dal lato comando.
- Orientamento bocche:
aspirante assiale / premente radiale rivolta verso l'alto.

APPLICAZIONI

Le pompe normalizzate serie NCD sono state studiate per i settori di utilizzo quali antincendio, acquedottistica, industriale, antibrina, irrigazione, impianti di riscaldamento e condizionamento di medie e grandi dimensioni e approvvigionamento idrico sia ad uso civile che industriale.

LIMITI D'IMPIEGO

- Temperatura max. liquido sollevato: +90°C. (esecuzione su richiesta +140°C.)
- Temperatura min. liquido sollevato: -10°C.
- Tempo max di funzionamento a bocca chiusa con liquido a 90°C.: 30 sec.
- Pressione nominale 10/16 bar (con flangiature secondo UNI 2223 PN16/PN25).
- Possibilità di veicolamento di tutti quei liquidi chimicamente e meccanicamente compatibili con i materiali costruttivi delle pompe.

Su richiesta possono essere fornite esecuzioni speciali.

PUMP CODING
ПОЯСНЕНИЯ К ОБОЗНАЧЕНИЯМ
ESEMPLIFICAZIONE SIGLA

Code - Обозначение - Sigla
NCD4P50-250

Series NCD (with Cast Iron impeller)
Серия NCD (с рабочим колесом из чугуна)
Serie NCD (con girante in ghisa)

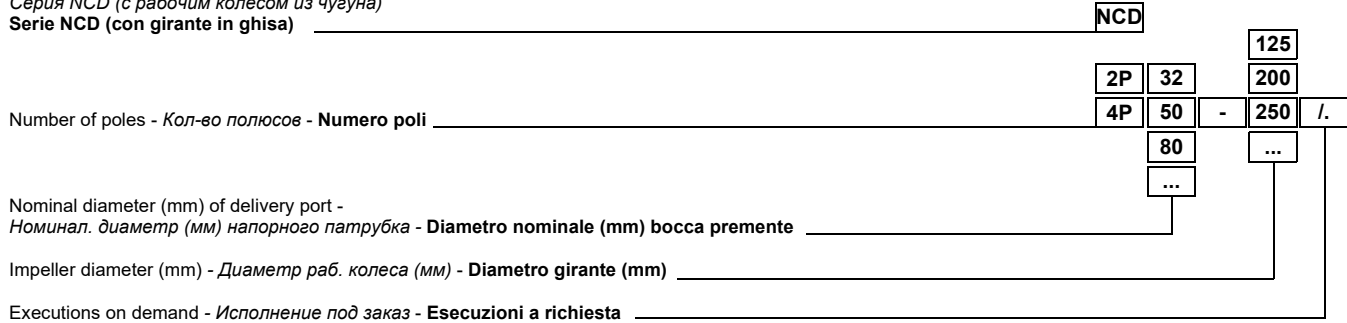

MECHANICAL SEAL

МЕХАНИЧЕСКОЕ УПЛОТНЕНИЕ

TENUTA MECCANICA

Component / Компонент / Particolare				
Type Тип Tipo	Ressort Пружина Molla	Joints Уплотнения Guarnizioni	Static seat Неподвижное кольцо Anello fisso	Rotatic seat Вращающееся кольцо Anello rotante
Material/ Материал / Materiale				
Standard	AISI 316	EPDM	SILICON CARBIDE КАРБИД КРЕМНИЯ CARBURO DI SILICIO	SILICON CARBIDE КАРБИД КРЕМНИЯ CARBURO DI SILICIO

PUMPED LIQUID

Conforming to : DIN 24960 - ISO 3069.

TOLERANCES

Service conditions have been measured with cold water (15°C - 59°F) at 1 bar atmospheric pressure. These tolerances are guaranteed with standard assembly line pumps built according to UNI/ISO 9906 Grade 3B. Catalogue data are for liquids with a density of 1 kg/dm³, and kinematic viscosity not exceeding 1 mm²/s.

REGULATIONS

Parameters not covered by EN733 (DIN24255): 80-400, 200-315, 200-400

ПЕРЕКАЧИВАЕМАЯ ЖИДКОСТЬ

Стандартизировано: DIN 24960 - ISO 3069.

ДОПУСКИ

Рабочие характеристики измерялись с использованием холодной воды (15 °C) при атмосферном давлении (1 бар). Поскольку речь идет о серийно производимых насосах, они гарантированы в соответствии со стандартами UNI/ISO 9906 Уровень 3B. Данные каталога относятся к жидкостям с плотностью 1 кг/дм³ и кинематической вязкостью не более 1 мм²/с.

НОРМАТИВЫ

Размеры, не предусмотренные в EN733 (DIN24255): 80-400, 200-315, 200-400

LIQUIDO DA SOLLEVARE

Secondo le norme : DIN 24960 - ISO 3069.

TOLLERANZE

Le caratteristiche di funzionamento sono state rilevate con acqua fredda (15°C) alla pressione atmosferica (1bar) e vengono garantite, trattandosi di pompe costruite in serie, secondo le norme UNI/ISO 9906 grado 3B. I dati di catalogo si riferiscono a liquidi con densità di 1kg/dm³ e con viscosità cinematica non superiore a 1mm²/s.

NORMATIVE

Grandezze non previste in EN733 (DIN2455): 80-400, 200-315, 200-400

Performance ranges
 Диапазон рабочих параметров
 Campi di prestazione

Performance curves at 50Hz / Рабочие характеристики при 50 Гц / Caratteristiche di funzionamento a 50Hz

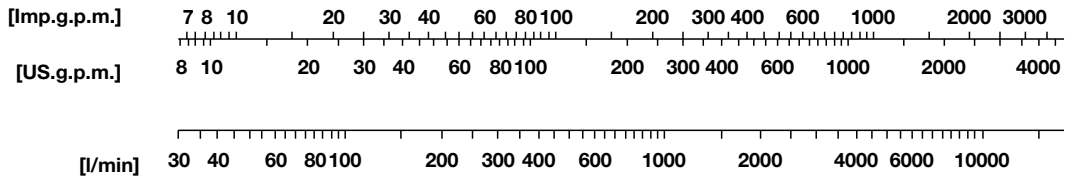
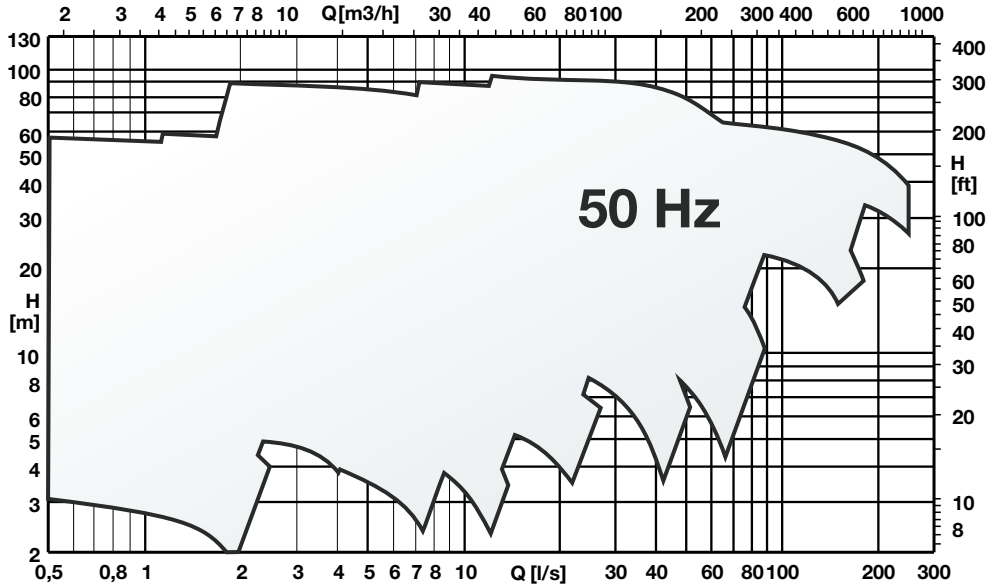

Performance curves at 60Hz / Рабочие характеристики à 60Hz / Caratteristiche di funzionamento a 60Hz

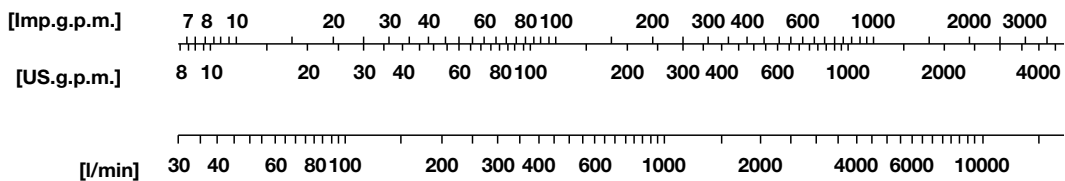
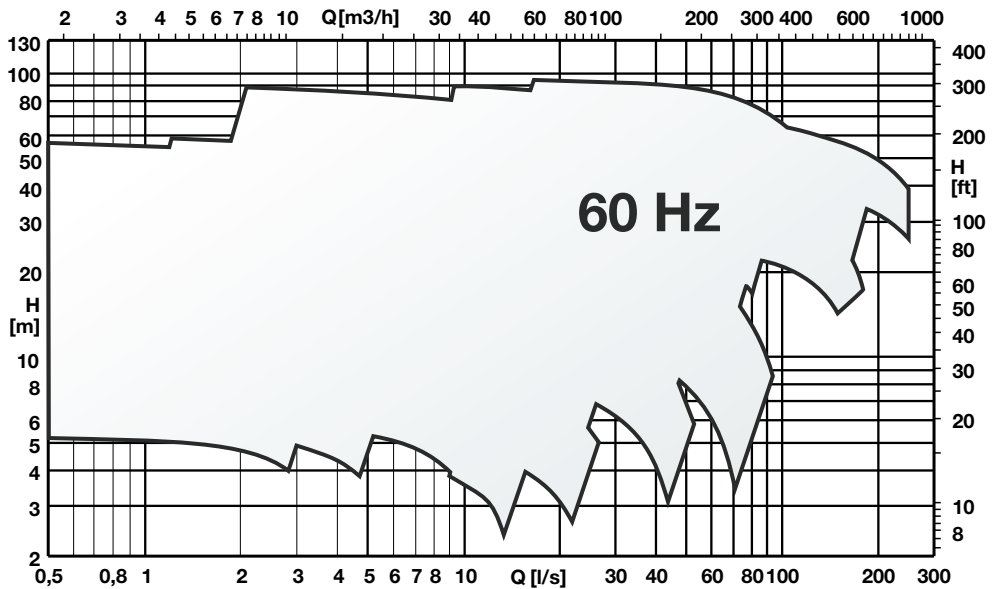

OPERATING LIMITS / РАБОЧИЙ ДИАПАЗОН / LIMITI DI FUNZIONAMENTO

Maximum speed Макс. скорость Velocità massima	[min ⁻¹]	Maximum speed Макс. скорость Velocità massima	[min ⁻¹]
NCD4P32-125	1450	NCD2P32-125	2900
NCD4P32-160		NCD2P32-160	
NCD4P32-200		NCD2P32L-160	
NCD4P40-160		NCD2P32-200	
NCD4P40-200		NCD2P32L-200	
NCD4P40-250		NCD2P40-125	
NCD4P50-125		NCD2P40-160	
NCD4P50-160		NCD2P40-200	
NCD4P50-200		NCD2P40-250	
NCD4P50-250		NCD2P50-125	
NCD4P65-125		NCD2P50-160	
NCD4P65-160		NCD2P50-200	
NCD4P65-200		NCD2P50-250	
NCD4P65-250		NCD2P65-125	
NCD4P65-315		NCD2P65-160	
NCD4P80-160		NCD2P65-200	
NCD4P80-200		NCD2P65-250	
NCD4P80-250		NCD2P80-160	
NCD4P80-315		NCD2P80-200	
NCD4P80-400		NCD2P80-250	
NCD4P100-200		NCD2P100-200	
NCD4P100-250		NCD2P100-250	
NCD4P100-315		NCDS2P32-125	3450
NCD4P100-400		NCDS2P32-160	
NCD4P125-250		NCDS2P32L-160	
NCD4P125-315		NCDS2P32-200	
NCD4P125-400		NCDS2P32L-200	
NCD4P150-315		NCDS2P40-125	
NCD4P150-400		NCDS2P40-160	
NCD4P200-315		NCDS2P40-200	
NCD4P200-400		NCDS2P40-250	
NCDS4P32-160		NCDS2P50-125	
NCDS4P32-200	NCDS2P50-160		
NCDS4P40-160	NCDS2P50-200		
NCDS4P40-200	NCDS2P50-250		
NCDS4P40-250	NCDS2P65-125		
NCDS4P50-160	NCDS2P65-160		
NCDS4P50-200	NCDS2P65-200		
NCDS4P50-250	NCDS2P65-250		
NCDS4P65-125	NCDS2P80-160		
NCDS4P65-160	NCDS2P80-200		
NCDS4P65-200	NCDS2P80-250		
NCDS4P65-250	NCDS2P100-200		
NCDS4P65-315	NCDS2P100-250		
NCDS4P80-160			
NCDS4P80-200			
NCDS4P80-250			
NCDS4P80-315			
NCDS4P80-400			
NCDS4P100-200			
NCDS4P100-250			
NCDS4P100-315			
NCDS4P100-400			
NCDS4P125-250			
NCDS4P125-315			
NCDS4P125-400			
NCDS4P150-315			
NCDS4P150-400			
NCDS4P200-315			
NCDS4P200-400			
NCDS4P200-400			

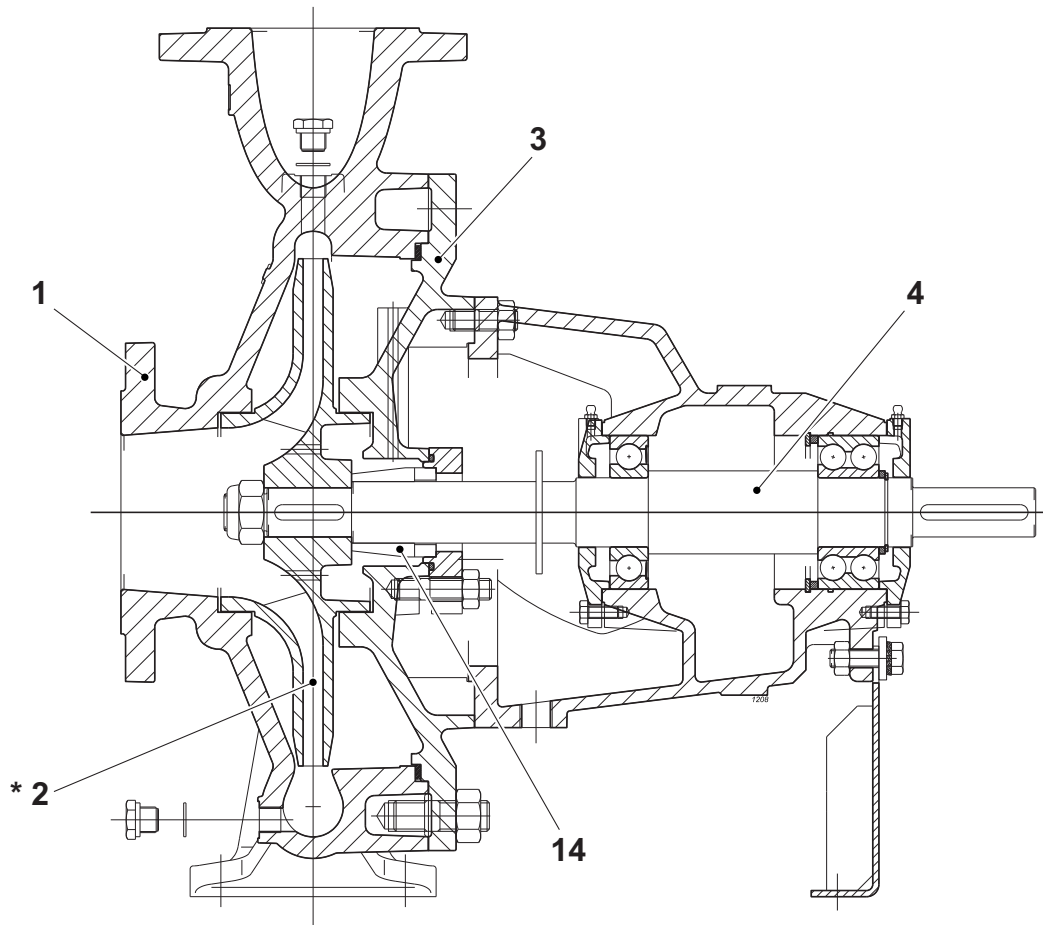

Pos.	Parts	Materials	Компонент	Материал	Nomenclatura	Materiale
1	Pump casing	Cast iron	Корпус насоса	Серый чугун	Corpo pompa	Ghisa grigia
2*	Impeller	Cast iron	Раб. колесо	Серый чугун	Girante	Ghisa grigia
3	Lantern bracket	Cast iron	Соединит. опора	Серый чугун	Supporto di collegamento	Ghisa grigia
4	Shaft	Stainless steel	Вая	Нержав. сталь	Albero	Acciaio inox
14	Mechanical seal	Carbon/Ceramic/ Rubber	Мех. уплотнение	Углерод/Керамика/ Резина	Tenuta meccanica	Carbone/Ceramica/ Gomma

Screws and nuts in stainless steel.

* The sizes 32-125, 32-160, 32L-200 and 40-200 have a bronze impeller.

Винты и гайки из нержавеющей стали.

* Типоразмеры 32-125, 32-160, 32L-200 и 40-200 имеют рабочее колесо из бронзы.

Viti e dadi in acciaio inox

* Le grandezze 32-125, 32-160, 32L-200 e 40-200 hanno il girante in bronzo.

Technical data standardized enclosed electric motors (Indicatives values according to the type of motor installed)
 Тех. данные стандартных закрытых электродвигателей (ориентировочные значения в зависимости от марки двигателя)
 Dati tecnici motore elettrico chiuso normalizzato (Valori indicativi in funzione della marca di motore utilizzato)

Motor power Мощность двигателя Potenza motore	2 Poles 50 Hz 2 Полюса 50 Гц 2 Poli 50 Hz			4 Poles 50 Hz 4 Полюса 50 Гц 4 Poli 50 Hz		
	Max. number starts/hour* Макс. кол-во пусков в час* Numero massimo di avviamenti/ora*	Voltage variation Изменение напряжения Variazione di tensione	Dynamic momentum J Динамич. момент J Momento dinamico J	Max. number starts/hour* Макс. кол-во пусков в час* Numero massimo di avviamenti/ora*	Voltage variation Изменение напряжения Variazione di tensione	Dynamic momentum J Динамич. момент J Momento dinamico J
[kW]		[%]	[kg m ²]		[%]	[kg m ²]
0,75	3	± 10 (400V)	0,001	3	± 10 (400V)	0,003
1,1	3	± 10 (400V)	0,002	3	± 10 (400V)	0,004
1,5	3	± 10 (400V)	0,002	3	± 10 (400V)	0,005
2,2	3	± 10 (400V)	0,003	3	± 10 (400V)	0,01
3	3	± 10 (400V)	0,005	3	± 10 (400V)	0,013
4	3	± 10 (400V)	0,008	3	± 10 (400V)	0,02
5,5	3	± 10 (400V)	0,014	3	± 10 (400V)	0,035
7,5	3	± 10 (400V)	0,017	3	± 10 (400V)	0,047
11	3	± 10 (400V)	0,051	3	± 10 (400V)	0,107
15	3	± 10 (400V)	0,064	3	± 10 (400V)	0,129
18,5	3	± 10 (400V)	0,076	3	± 10 (400V)	0,19
22	3	± 10 (400V)	0,117	3	± 10 (400V)	0,226
30	3	± 10 (400V)	0,174	3	± 10 (400V)	0,361
37	3	± 10 (400V)	0,205	3	± 10 (400V)	0,63
45	3	± 10 (400V)	0,302	3	± 10 (400V)	0,738
55	3	± 10 (400V)	0,408	3	± 10 (400V)	1,024
75 ○	3	± 10 (400V)	0,677	3	± 10 (400V)	1,4723
90 ○	3	± 10 (400V)	0,8001	3	± 10 (400V)	1,6775
110 ○	3	± 10 (400V)	1,5379	3	± 10 (400V)	3,4327
132 ○	3	± 10 (400V)	1,8654	3	± 10 (400V)	3,9943

- Axial drive only, by flexible coupling.
 - Electric motor operating limits in compliance with IEC 34-1

- Только осевой привод с помощью упругой муфты.
 - Рабочий диапазон для электродвигателей в соответствии с IEC 34-1.

- Azionamento solo coassiale tramite giunto elastico.
 - Limiti d'utilizzo motore elettrico secondo IEC 34-1.

* Equally distributed.
 ".-" = Contact the sales network

* Рекомендуется равномерное распределение.
 ".-" = Обратитесь в коммерческий отдел.

* Consigliati equamente ripartiti.
 ".-" = Contattare la rete di vendita

SPECIFICATIONS
 Efficiency class: IE3
 ○ Motor in IE4 efficiency class according to EU REGULATION 2019/1781.
 Available in other efficiency classes for non-EU markets.

ХАРАКТЕРИСТИКИ
 Класс эффективности: IE3.
 ○ Двигатель класса эффективности IE4 в соответствии с РЕГЛАМЕНТОМ ЕС 2019/1781.
 Имеются варианты в других классах эффективности для рынков за пределами ЕС.

CARATTERISTICHE
 Classe di efficienza: IE3
 ○ Motore in classe di efficienza IE4 in conformità al REGOLAMENTO UE2019/1781.
 Disponibili in altre classi di efficienza per mercati extra UE.

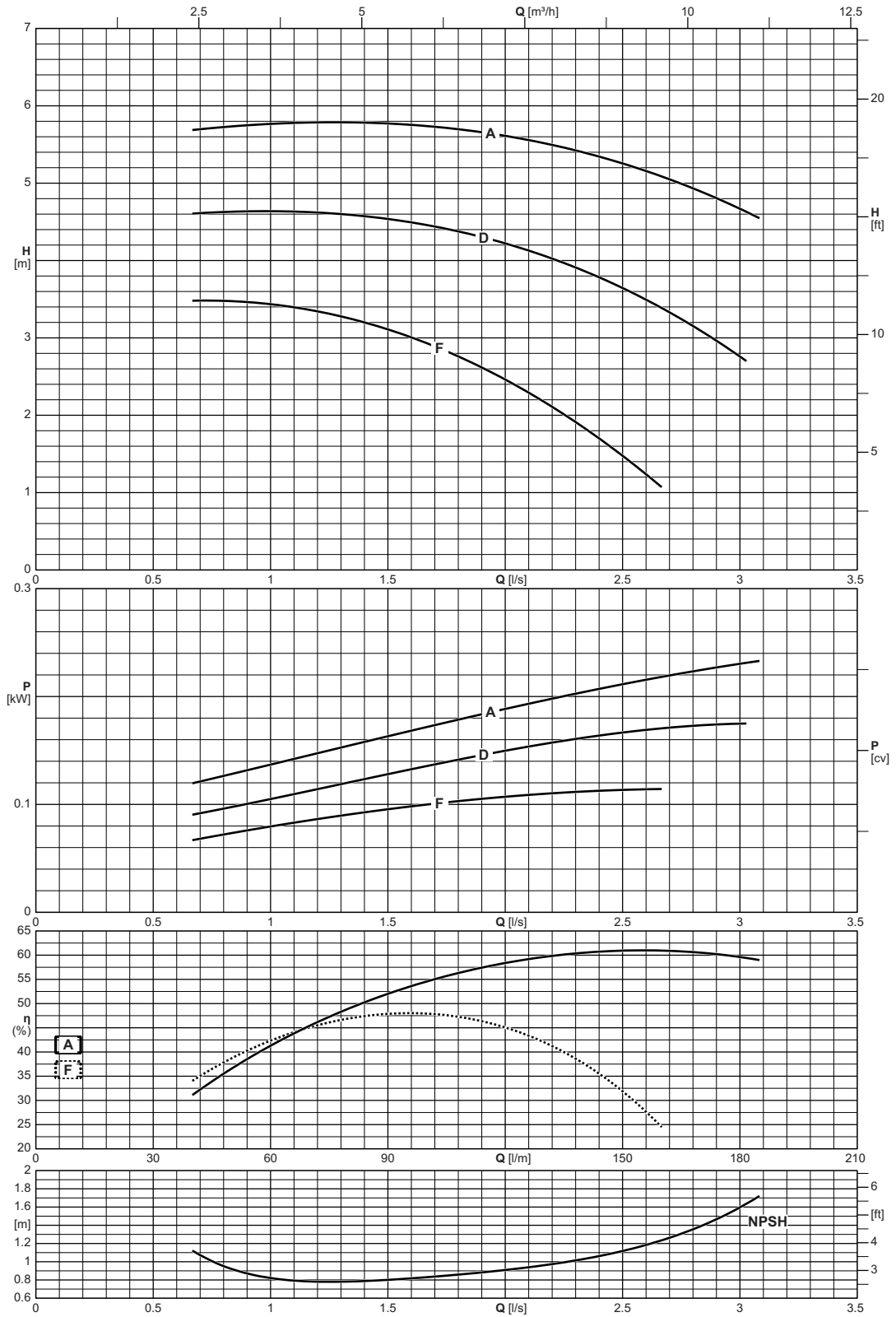

Type Тип Tipo	Inlet maximum pressure Макс. давление на всасывании Pressione massima in aspirazione
NCD4P32-125	[bar] 10

NCD 4P32-160

1450 n [min⁻¹]

ErP Ready



Operating data
Рабочие характеристики
Caratteristiche di funzionamento

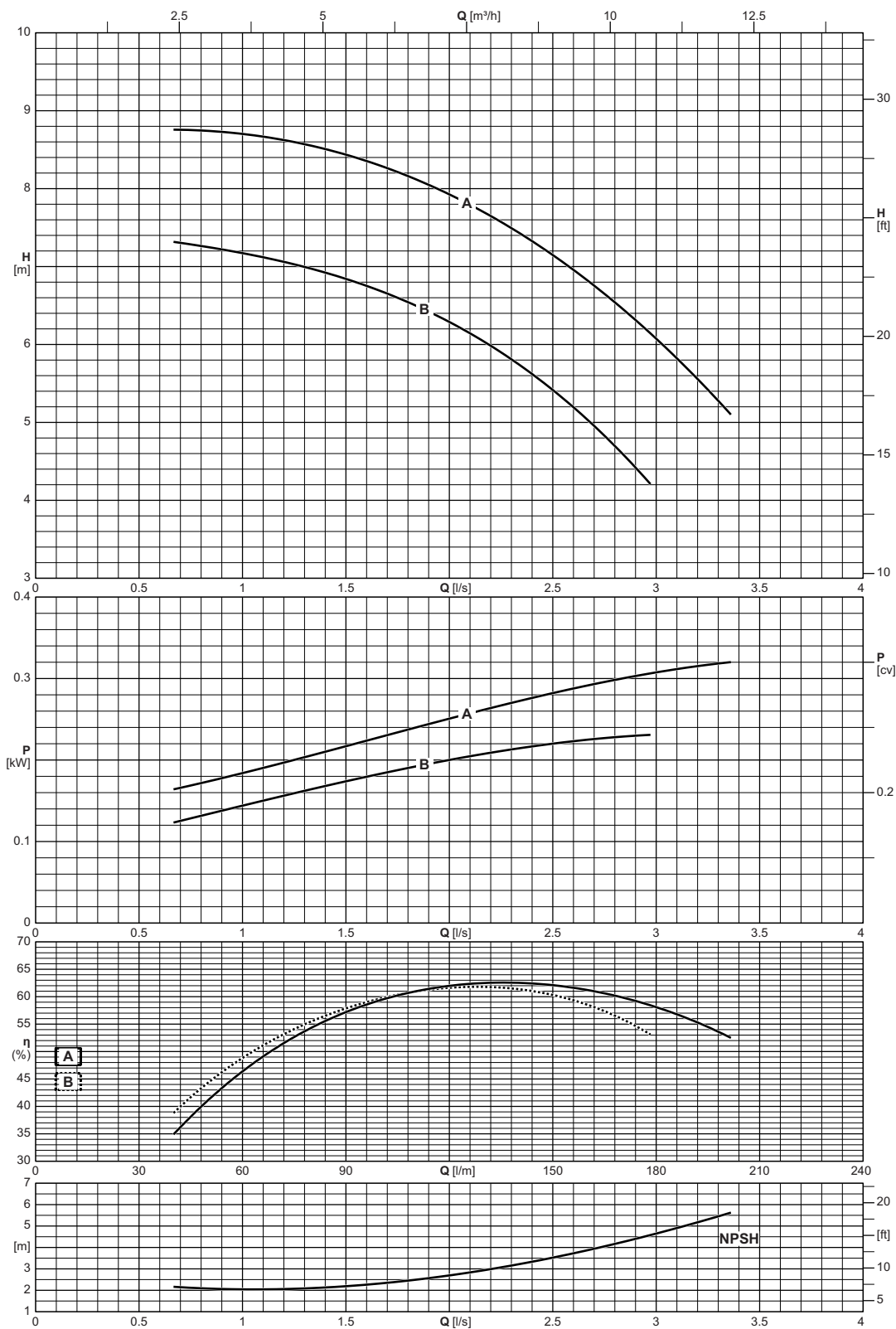

Type Тип Tipo	Inlet maximum pressure Макс. давление на всасывании Pressione massima in aspirazione
NCD4P32-160	[bar] 10

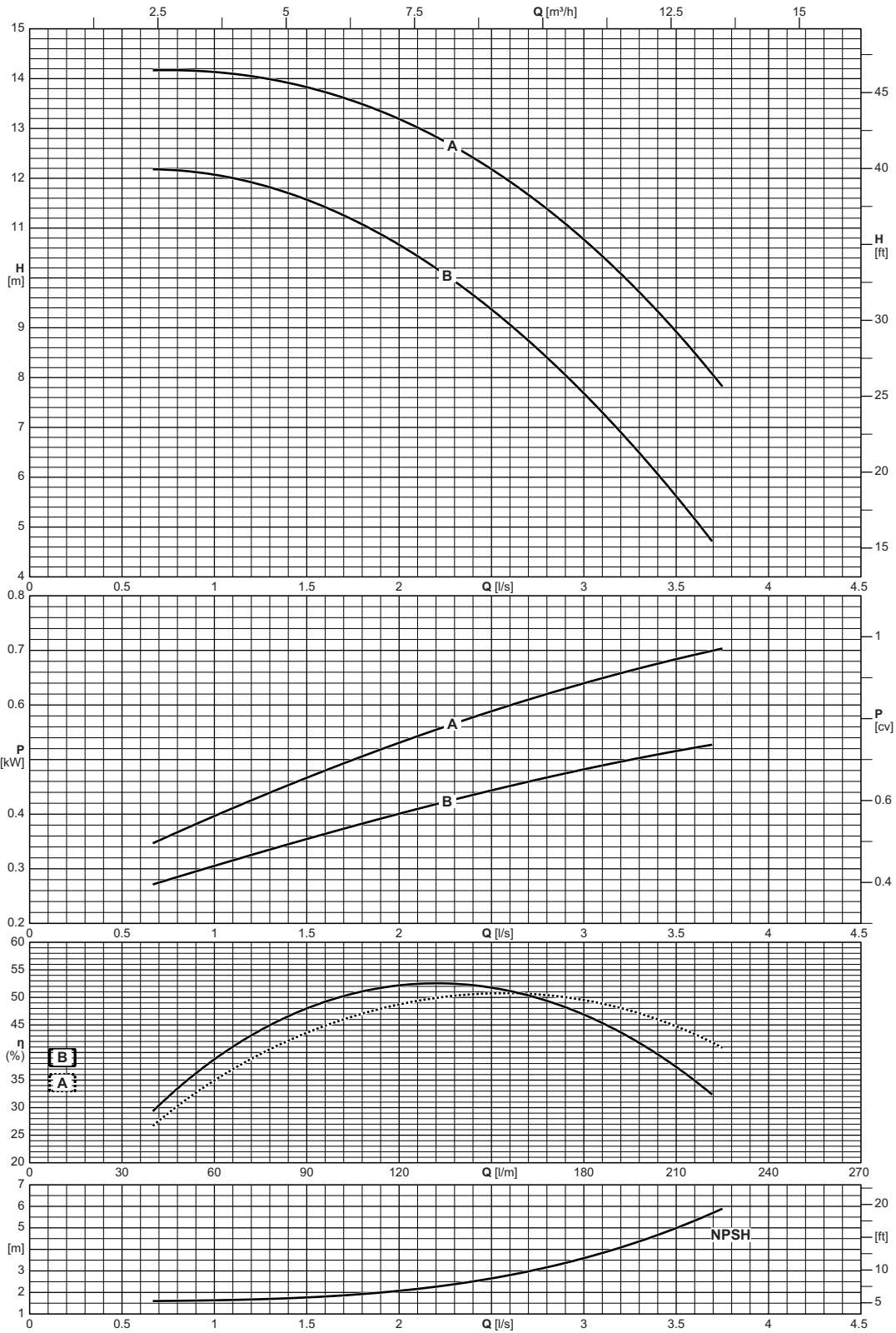

Type Тип Tipo	Inlet maximum pressure Макс. давление на всасывании Pressione massima in aspirazione
NCD4P32-200	[bar] 10

NCD 4P40-160

1450 n [min⁻¹]

ErP Ready



Operating data
Рабочие характеристики
Caratteristiche di funzionamento

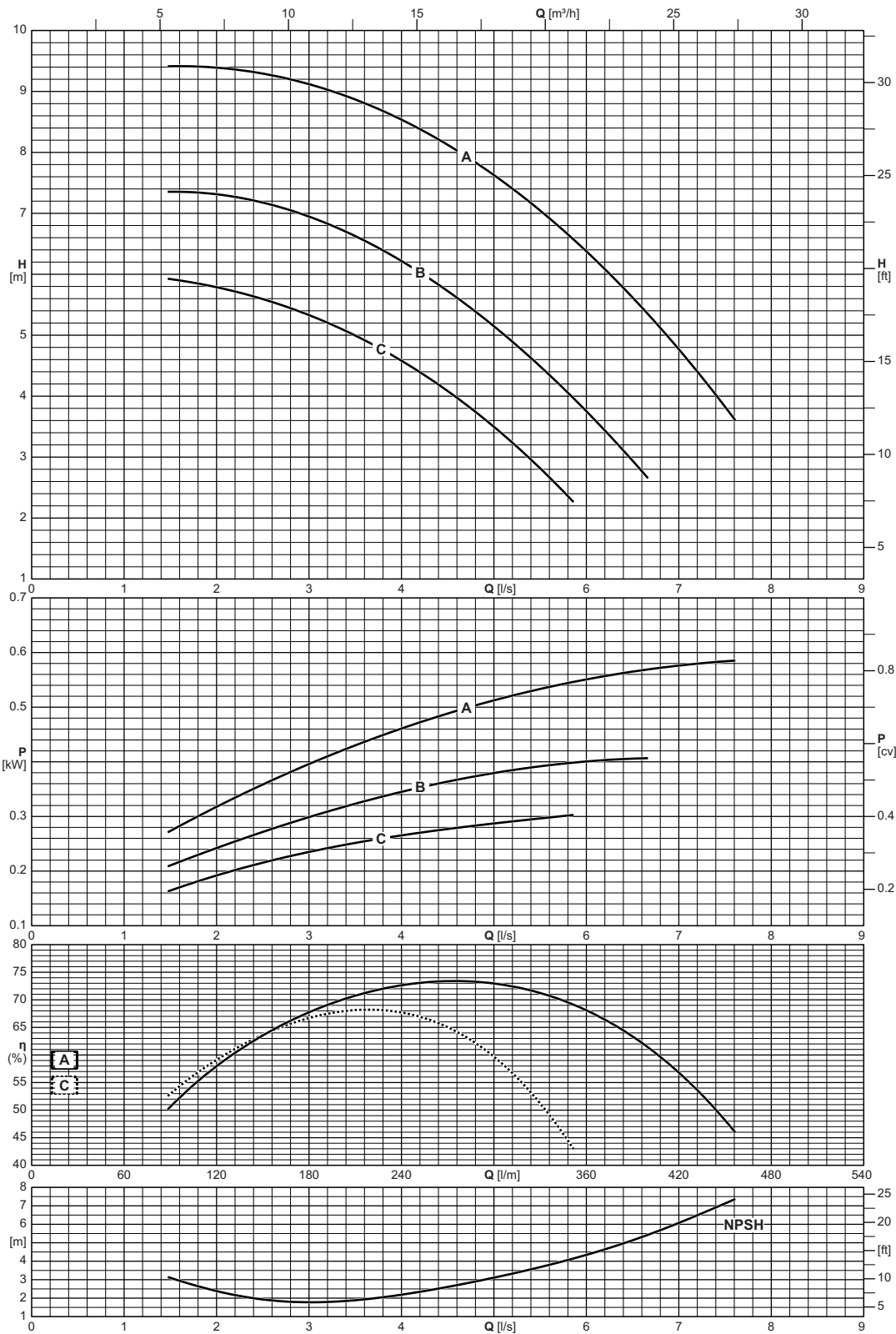

Type Тип Tipo	Inlet maximum pressure Макс. давление на всасывании Pressione massima in aspirazione
NCD4P40-160	[bar] 16

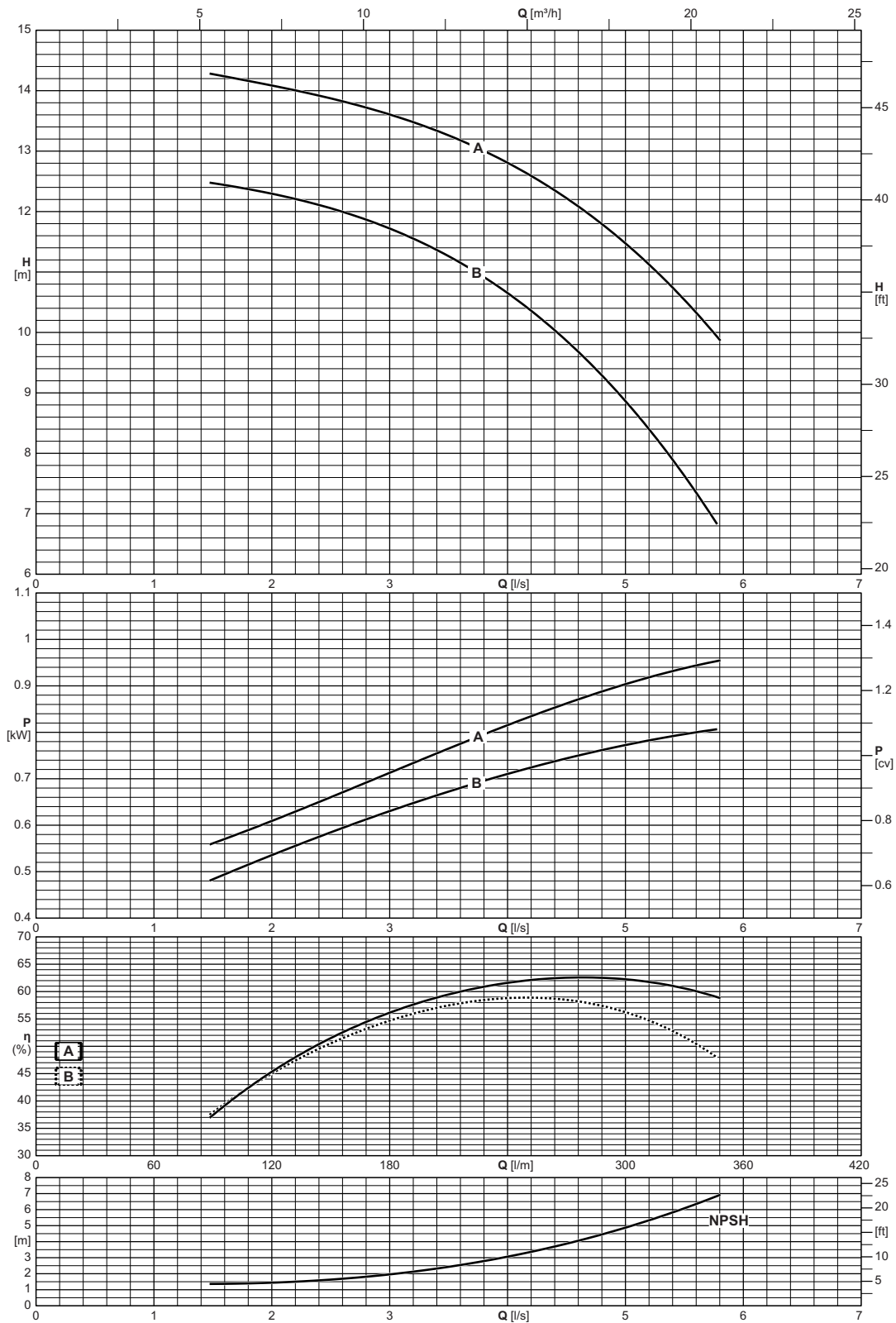

Type Тип Tipo	Inlet maximum pressure Макс. давление на всасывании Pressione massima in aspirazione
NCD4P40-200	[bar] 16

NCD 4P40-250

1450 n [min⁻¹]

ErP Ready



Operating data
Рабочие характеристики
Caratteristiche di funzionamento

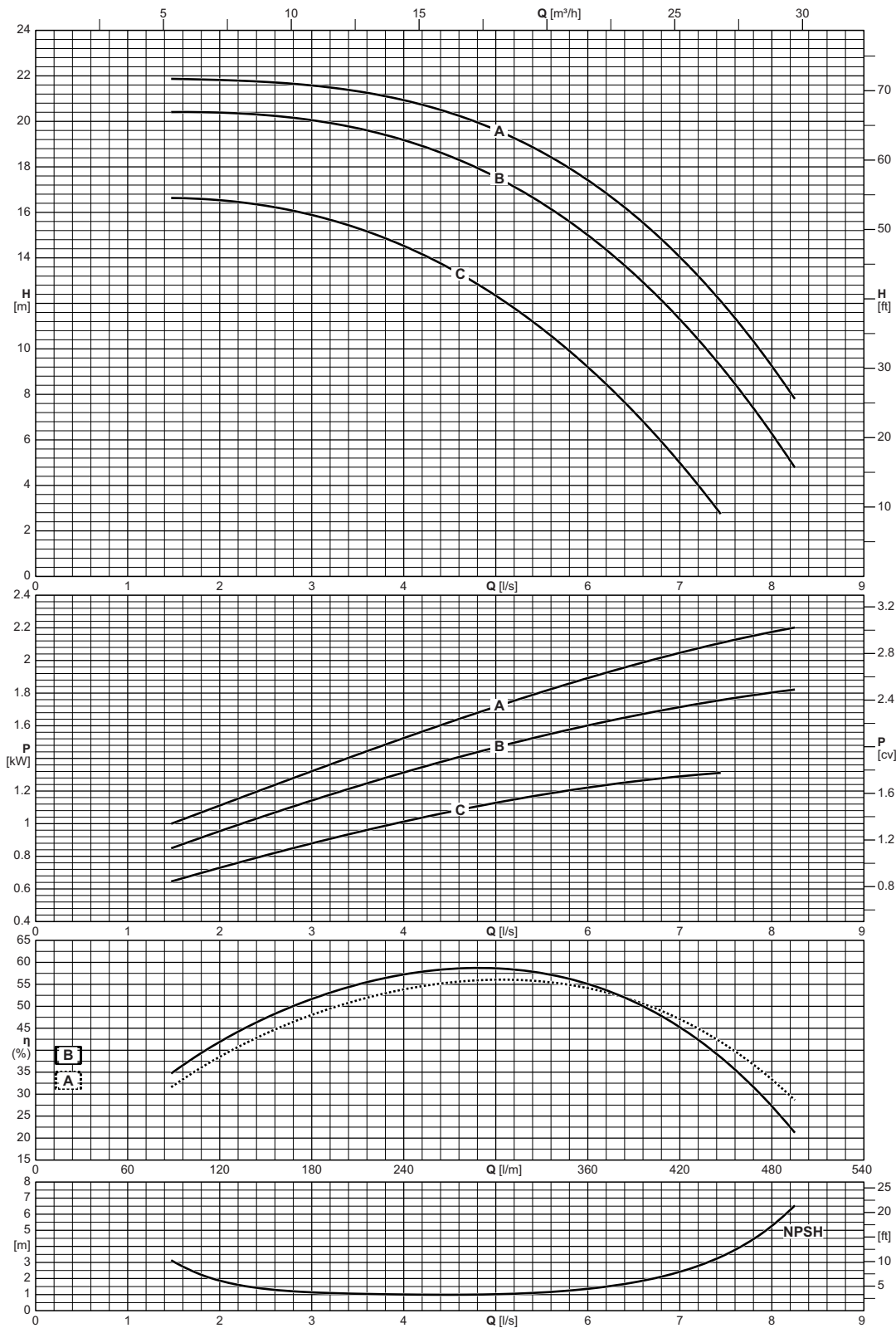

Type Тип Tipo	Inlet maximum pressure Макс. давление на всасывании Pressione massima in aspirazione
	[bar]
NCD4P40-250	10

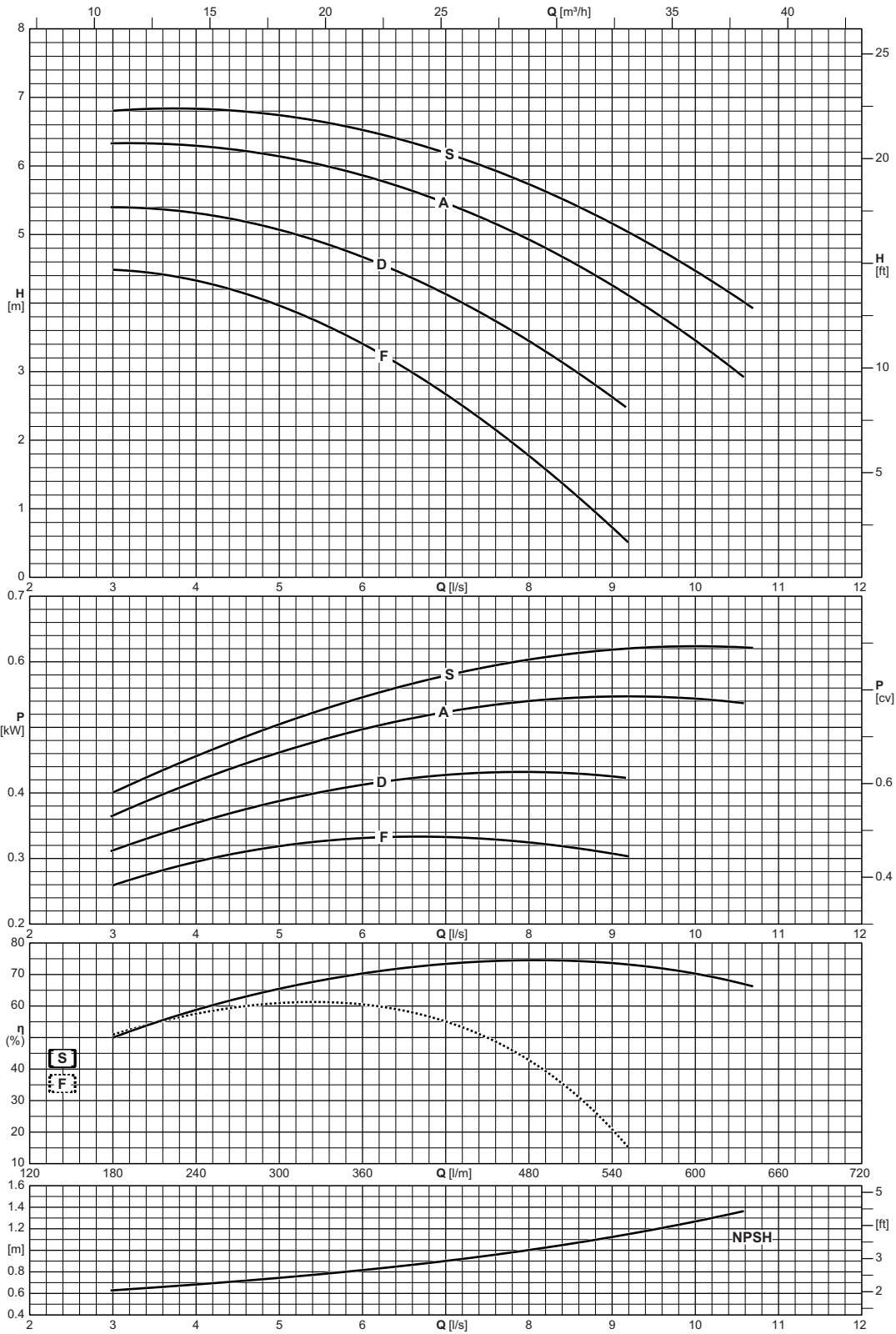

Type Тип Tipo	Inlet maximum pressure Макс. давление на всасывании Pressione massima in aspirazione
NCD4P50-125	[bar] 16

NCD 4P50-160

1450 n [min⁻¹]

ErP Ready



Operating data
Рабочие характеристики
Caratteristiche di funzionamento

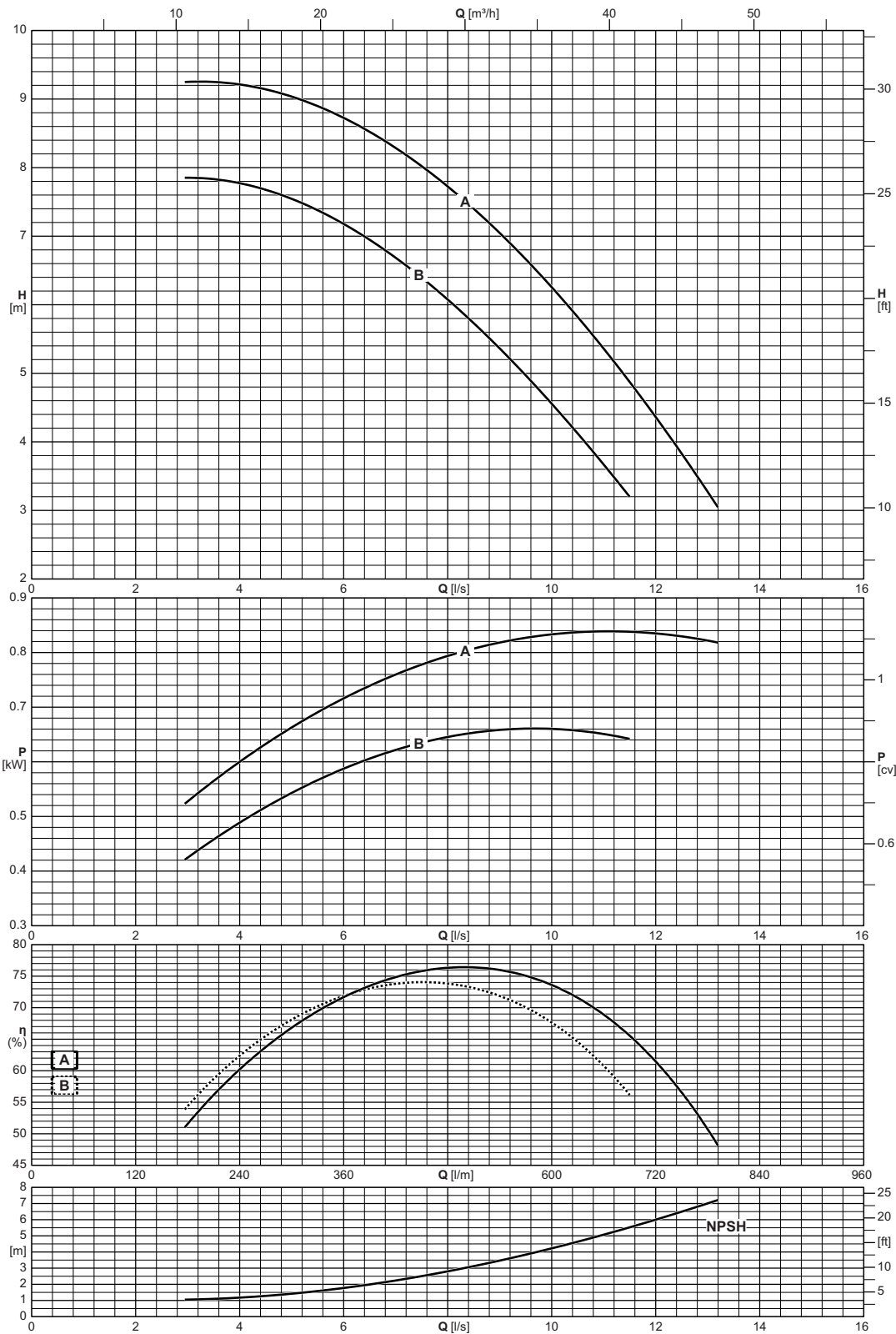

Type Тип Tipo	Inlet maximum pressure Макс. давление на всасывании Pressione massima in aspirazione
NCD4P50-160	[bar] 16

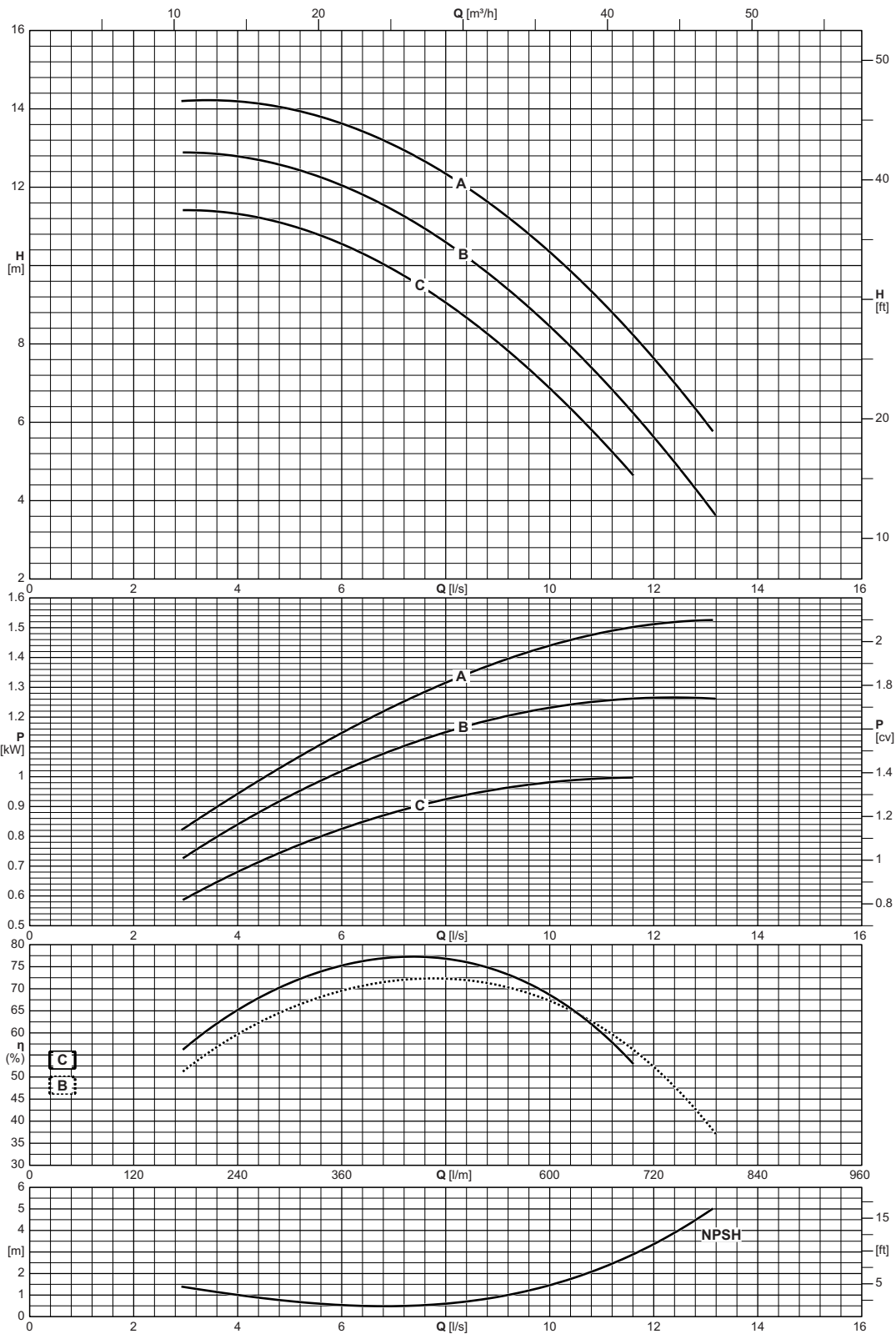

Type <i>Tun</i> Tipo	Inlet maximum pressure <i>Макс. давление на всасывании</i> Pressione massima in aspirazione
NCD4P50-200	[bar] 10

NCD 4P50-250

1450 n [min⁻¹]

ErP Ready



Operating data
Рабочие характеристики
Caratteristiche di funzionamento

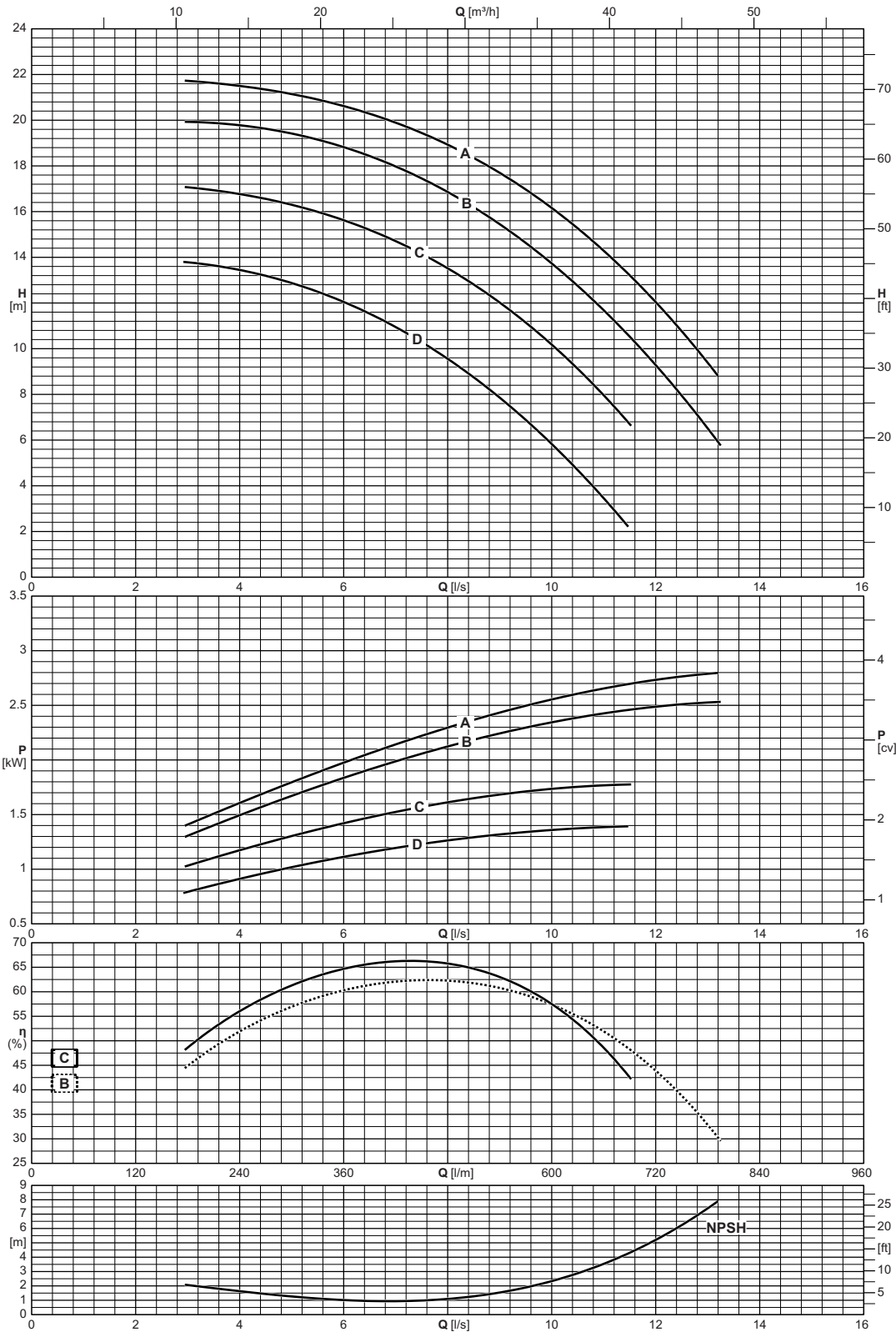

Type Тип Tipo	Inlet maximum pressure Макс. давление на всасывании Pressione massima in aspirazione
NCD4P50-250	[bar] 10

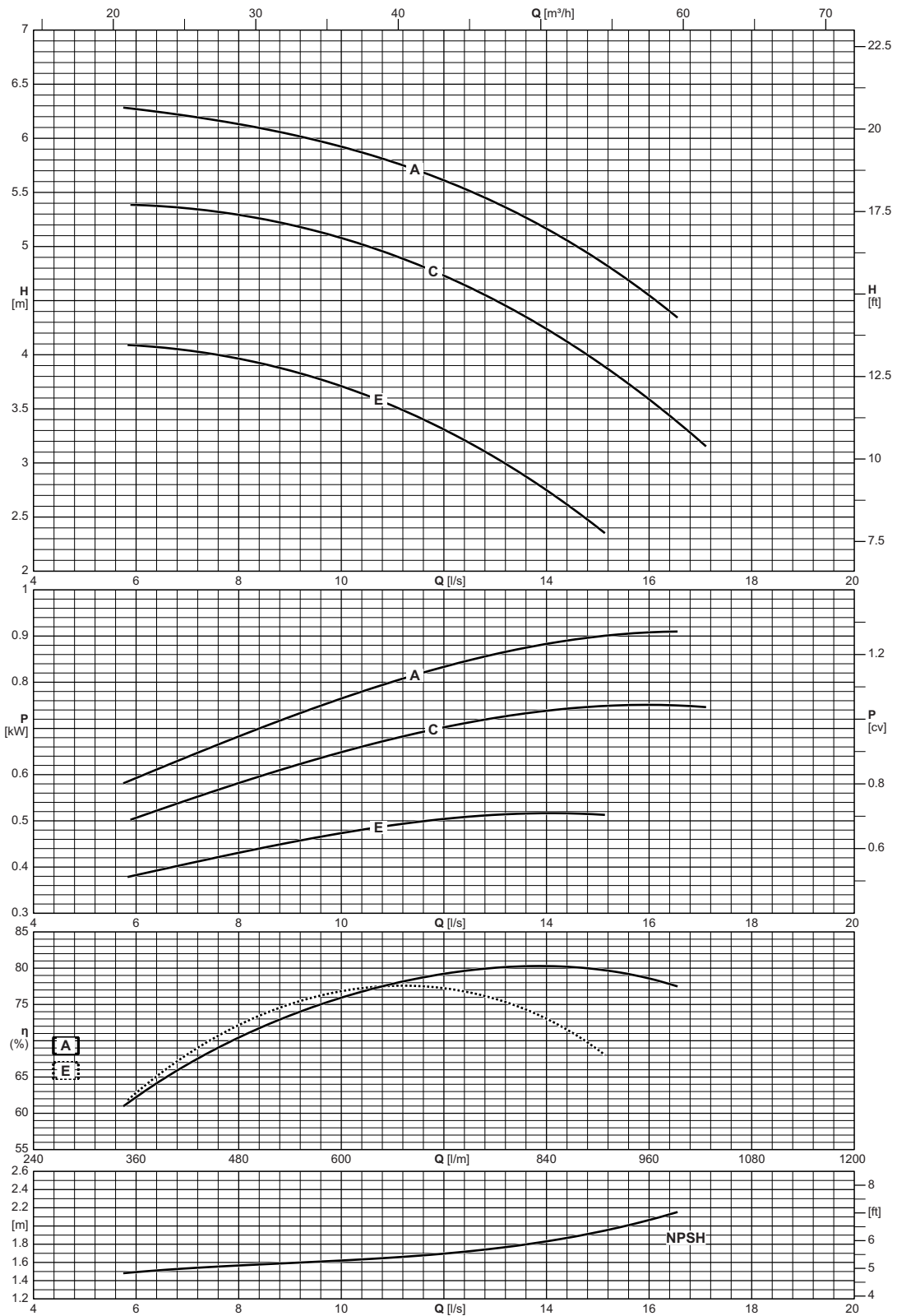

Type Тип Tipo	Inlet maximum pressure Макс. давление на всасывании Pressione massima in aspirazione
	[bar]
NCD4P65-125	16

NCD 4P65-160

1450 n [min⁻¹]

ErP Ready



Operating data
Рабочие характеристики
Caratteristiche di funzionamento

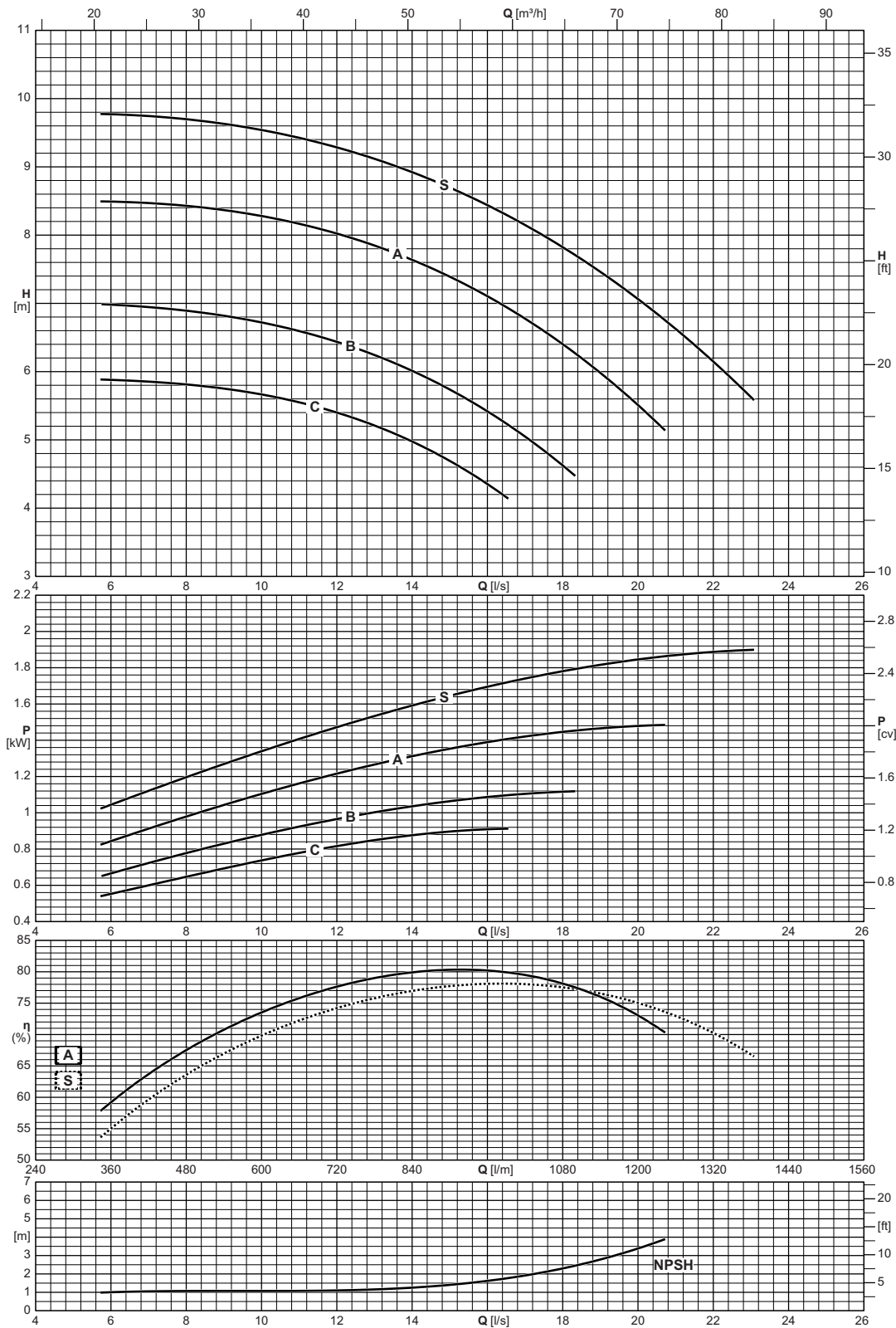

Type Тип Tipo	Inlet maximum pressure Макс. давление на всасывании Pressione massima in aspirazione
NCD4P65-160	[bar] 16

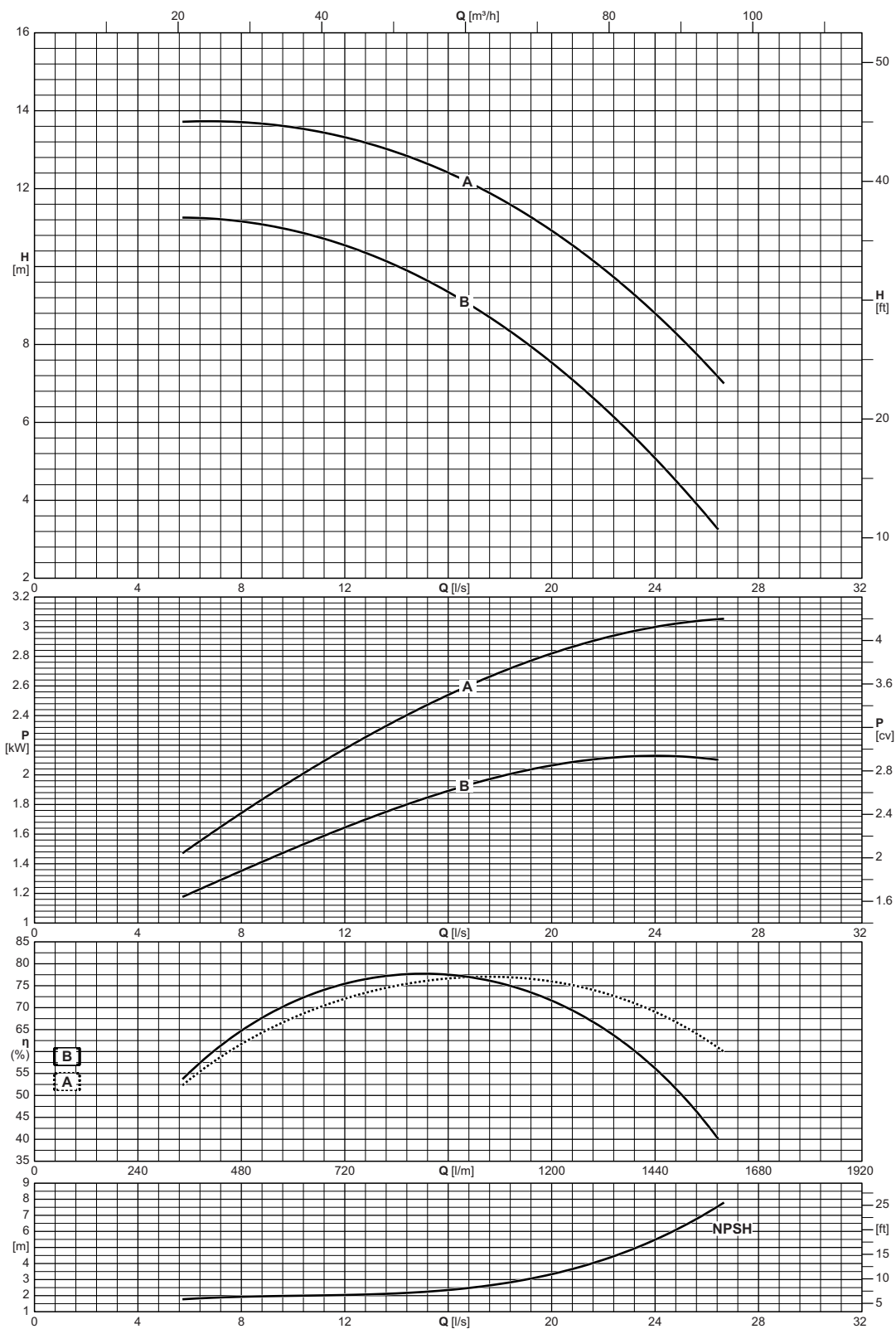

Type Тип Tipo	Inlet maximum pressure Макс. давление на всасывании Pressione massima in aspirazione
NCD4P65-200	[bar] 16

NCD 4P65-250

1450 n [min⁻¹]

ErP Ready



Operating data
Рабочие характеристики
Caratteristiche di funzionamento

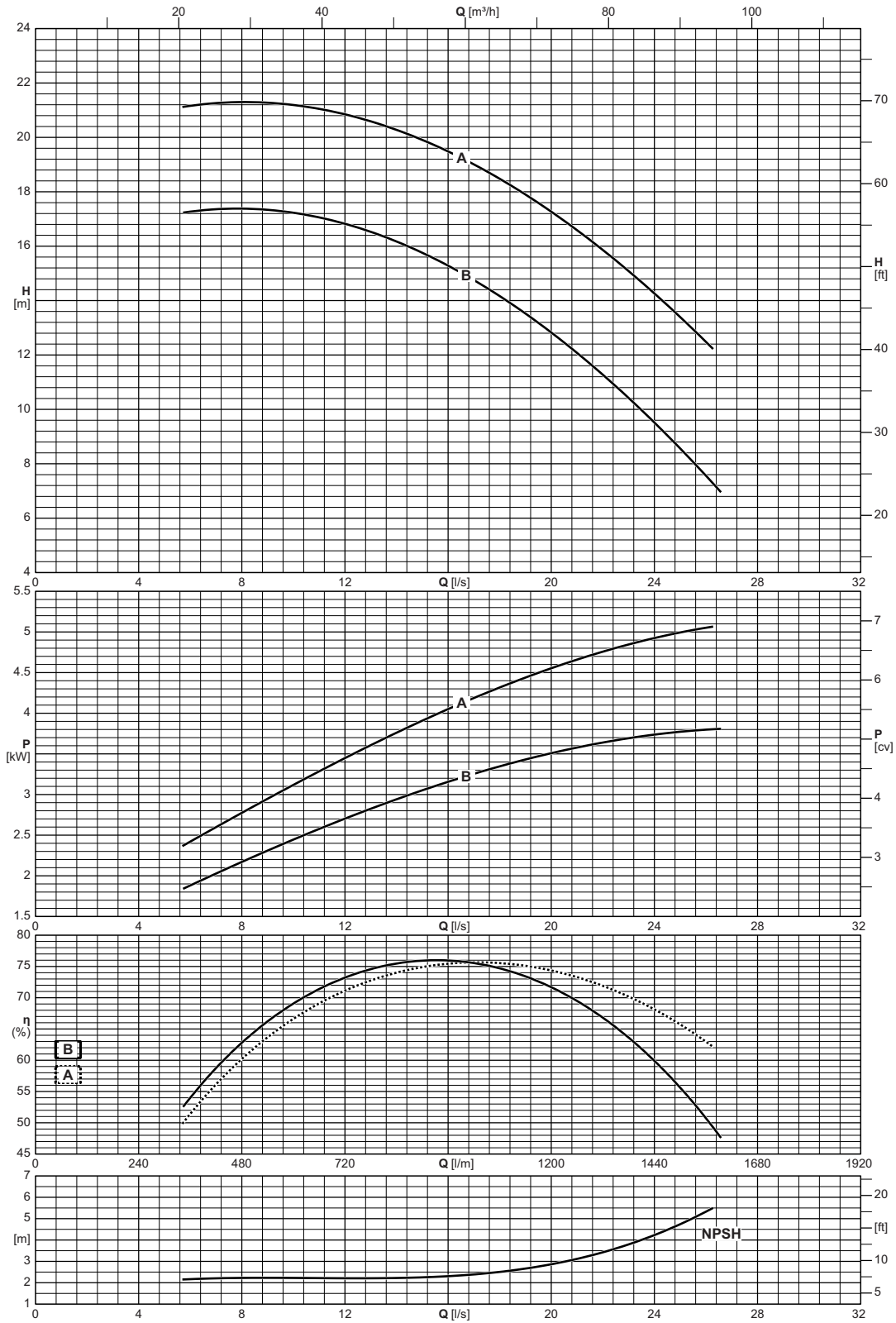

Type Тип Tipo	Inlet maximum pressure Макс. давление на всасывании Pressione massima in aspirazione
NCD4P65-250	[bar] 16

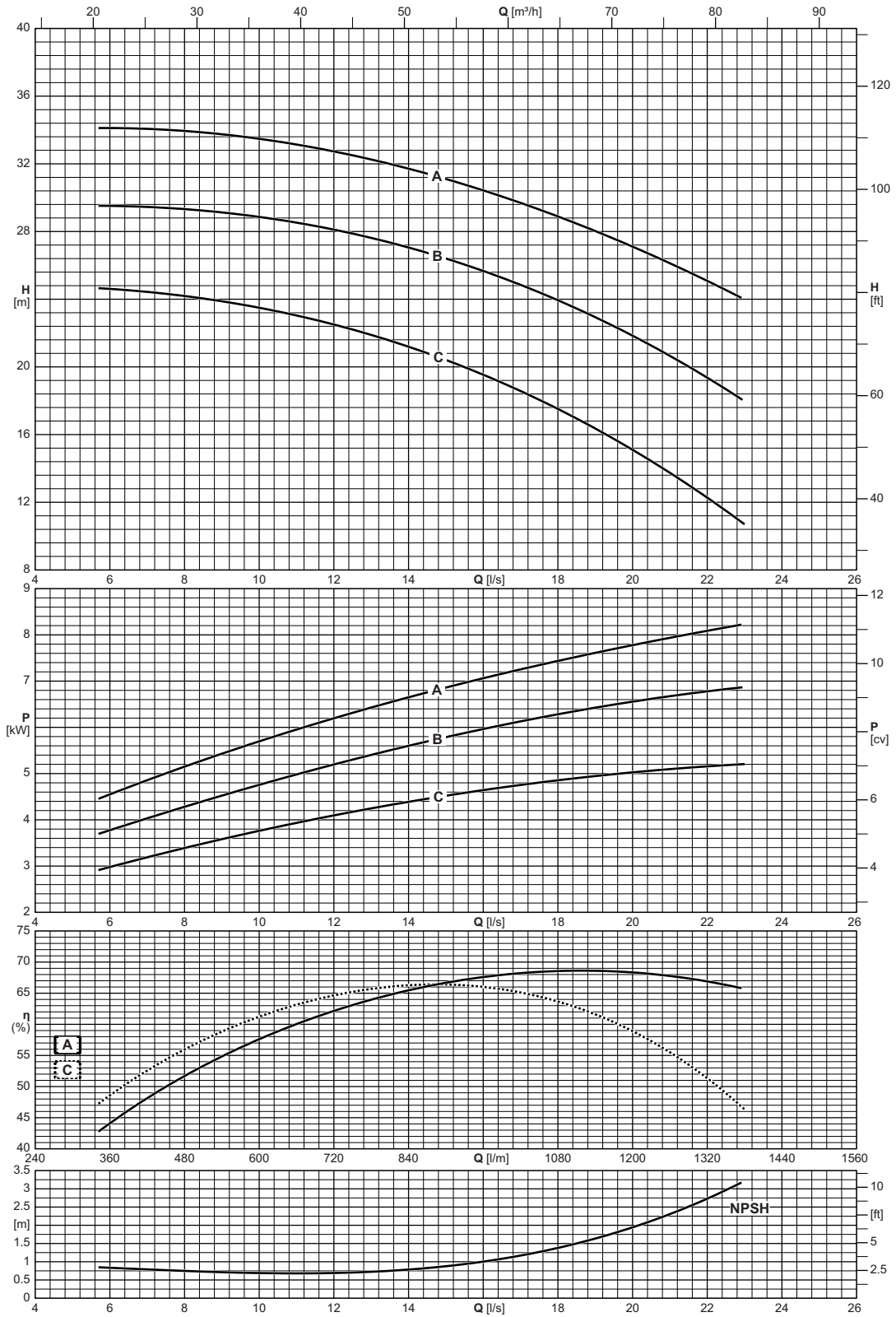

Type Тип Tipo	Inlet maximum pressure Макс. давление на всасывании Pressione massima in aspirazione [bar]
NCD4P65-315	10

NCD 4P80-160

1450 n [min⁻¹]

ErP Ready



Operating data
Рабочие характеристики
Caratteristiche di funzionamento

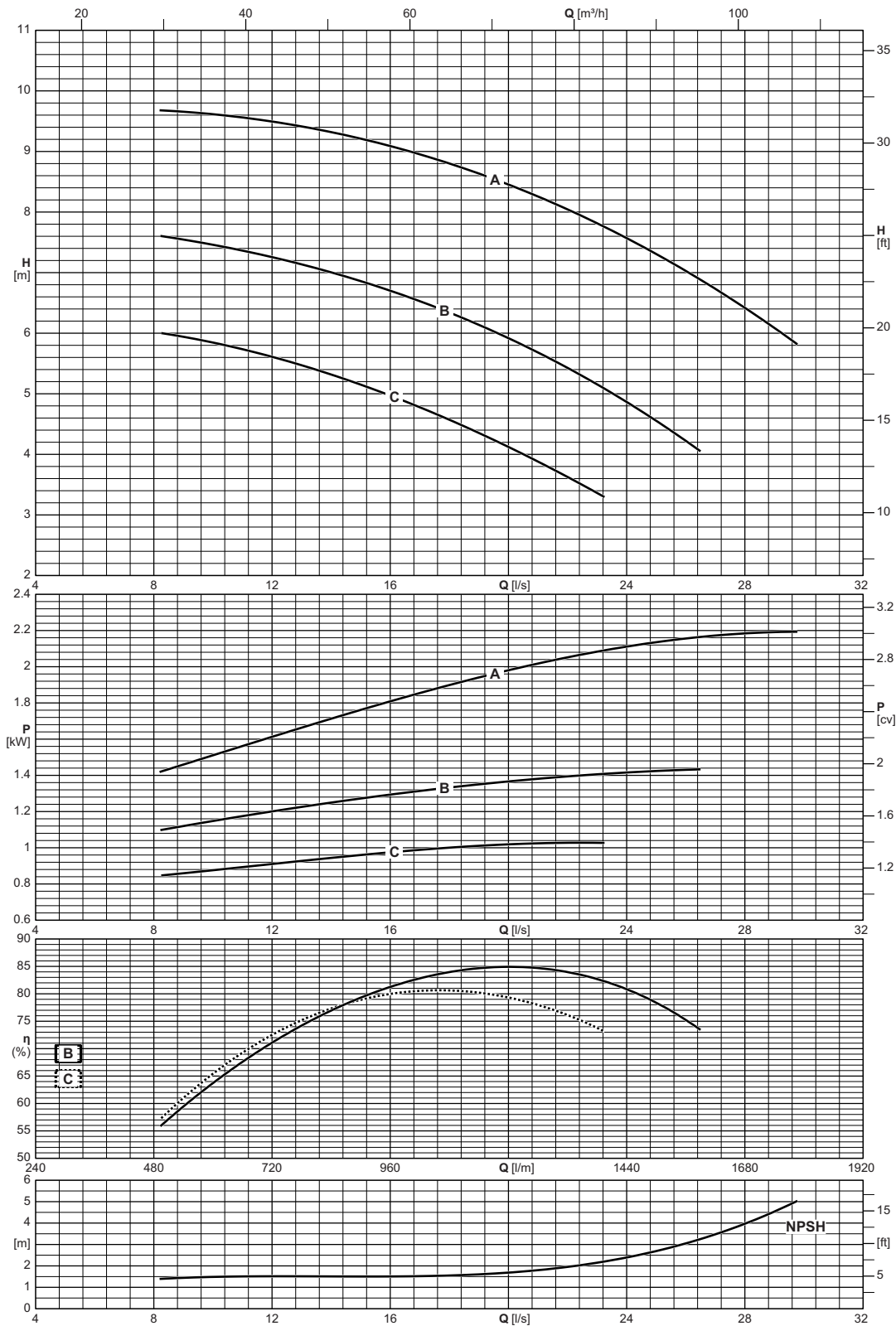

Type Тип Tipo	Inlet maximum pressure Макс. давление на всасывании Pressione massima in aspirazione
	[bar]
NCD4P80-160	16

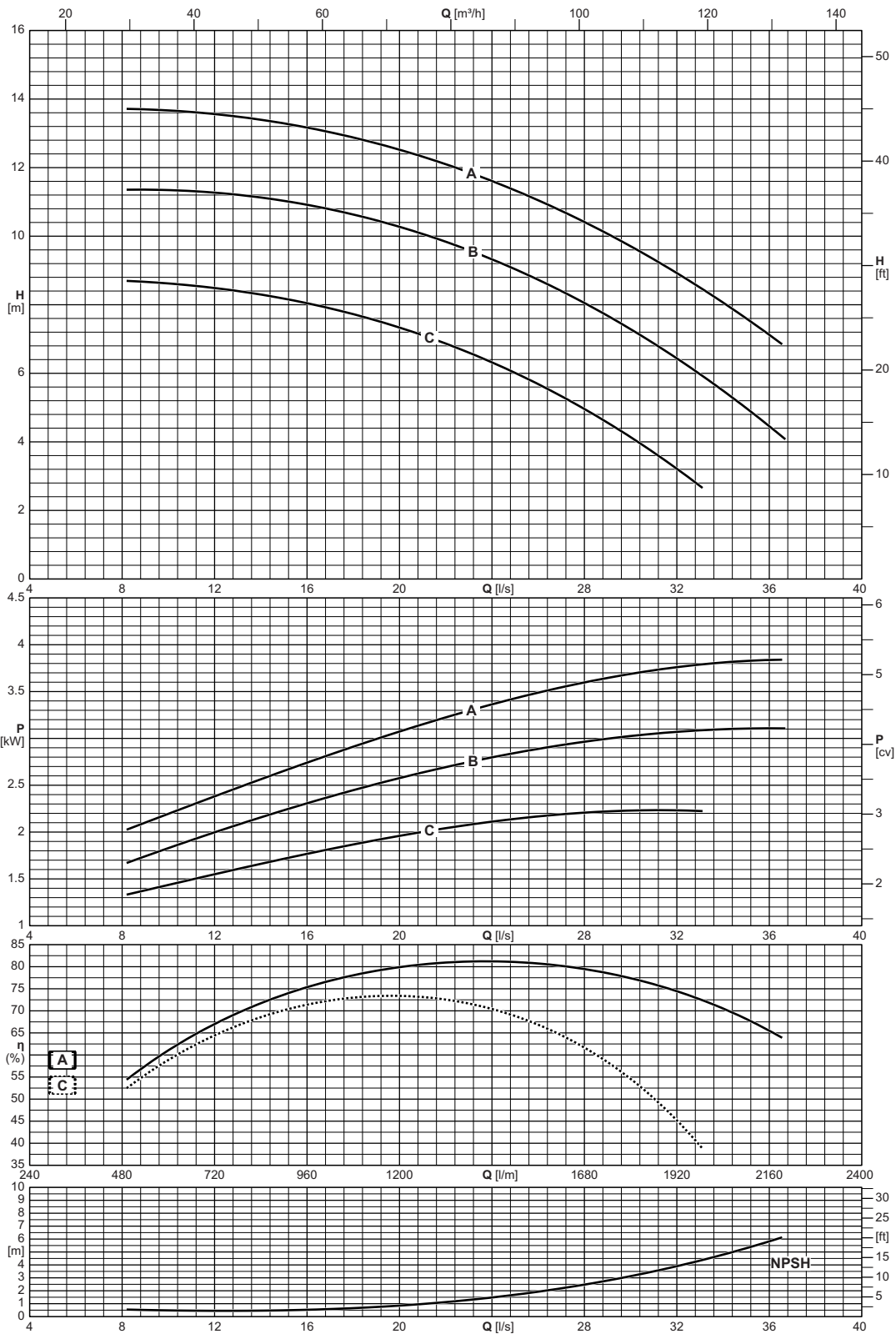

Type Тип Tipo	Inlet maximum pressure Макс. давление на всасывании Pressione massima in aspirazione
NCD4P80-200	[bar] 10

NCD 4P80-250

1450 n [min⁻¹]

ErP Ready



Operating data
Рабочие характеристики
Caratteristiche di funzionamento

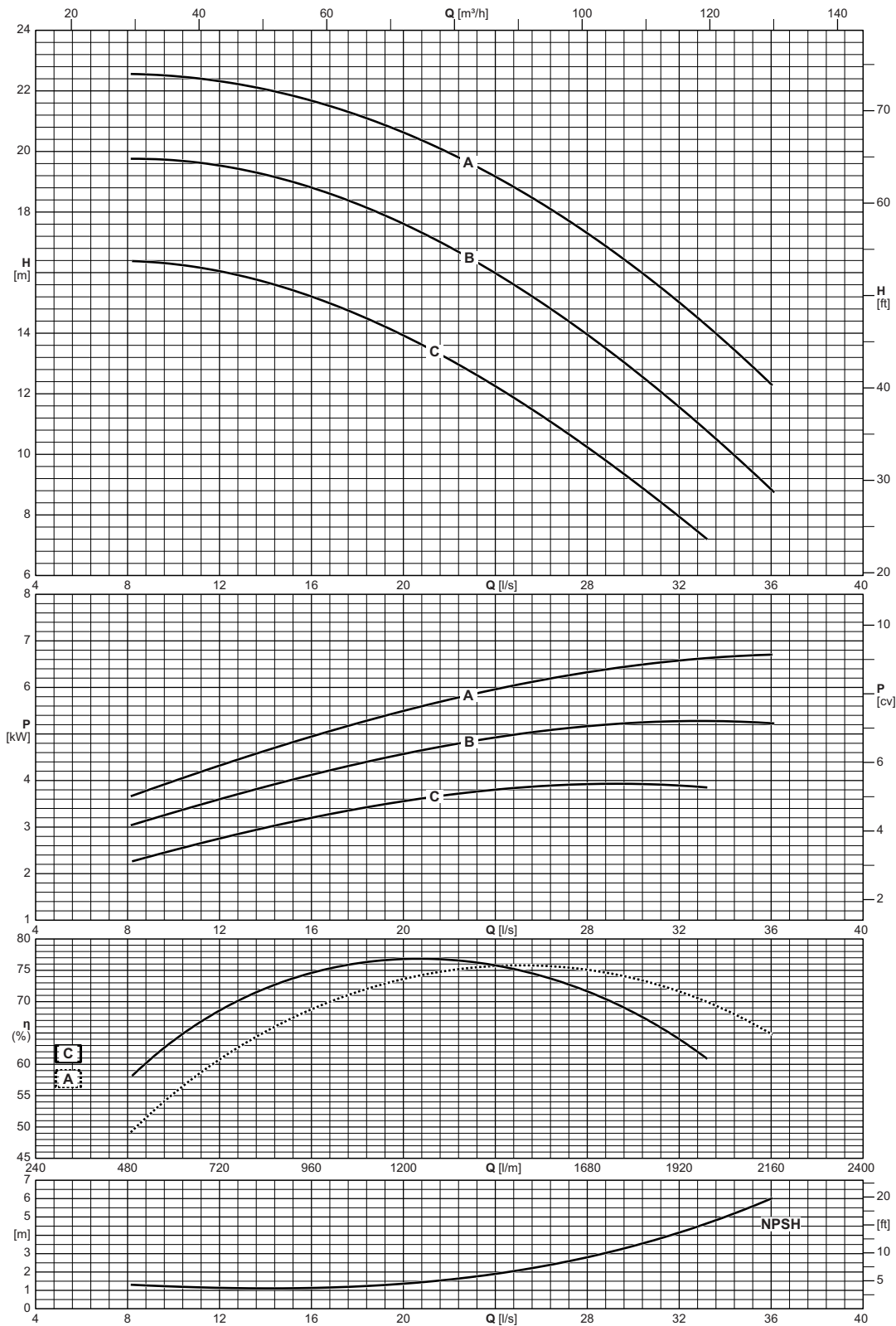

Type Тип Tipo	Inlet maximum pressure Макс. давление на всасывании Pressione massima in aspirazione
NCD4P80-250	[bar] 16

Operating data
Рабочие характеристики
Caratteristiche di funzionamento

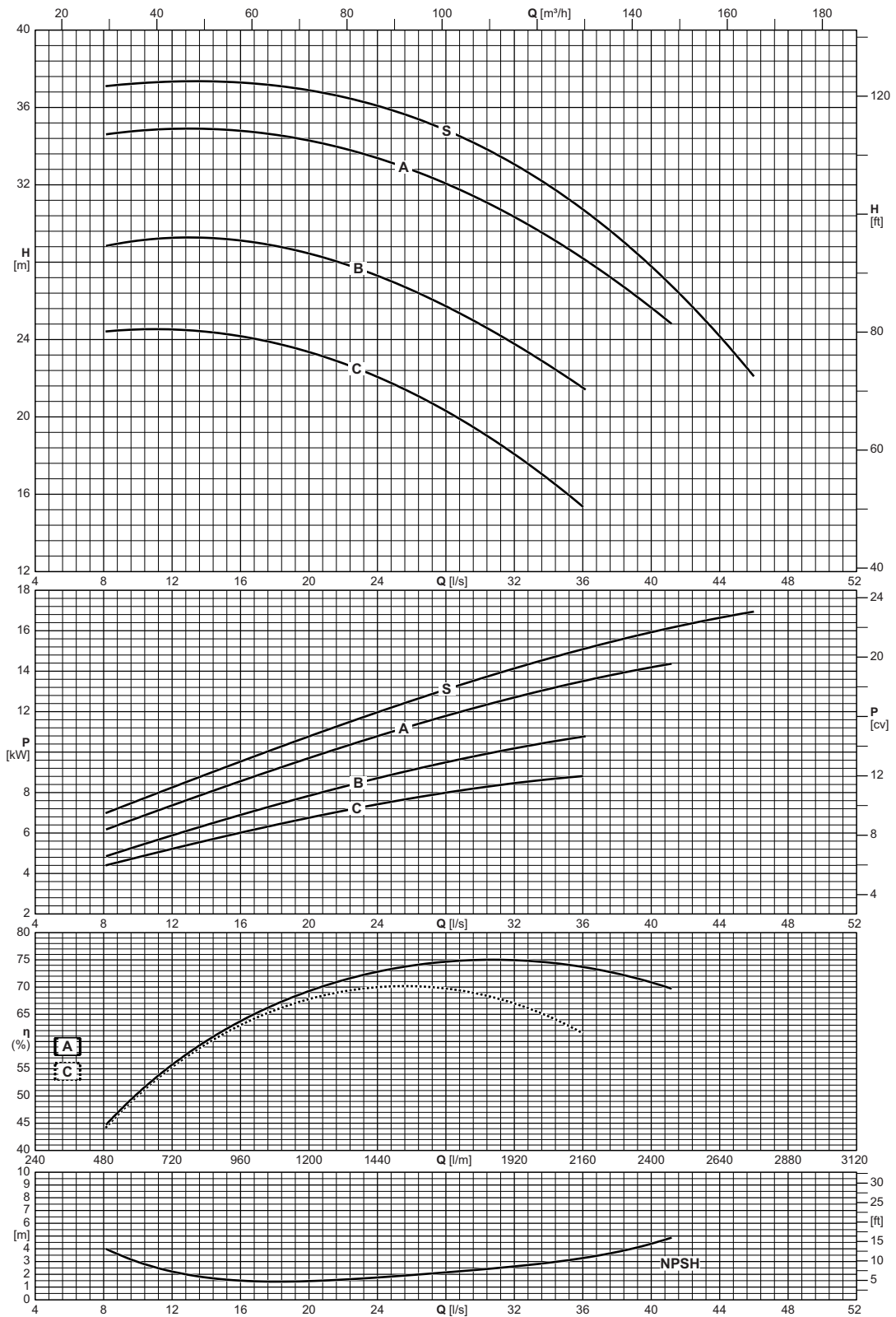

Type Тип Tipo	Inlet maximum pressure Макс. давление на всасывании Pressione massima in aspirazione
NCD4P80-315	[bar] 16

NCD 4P80-400

1450 n [min⁻¹]



Operating data
Рабочие характеристики
Caratteristiche di funzionamento

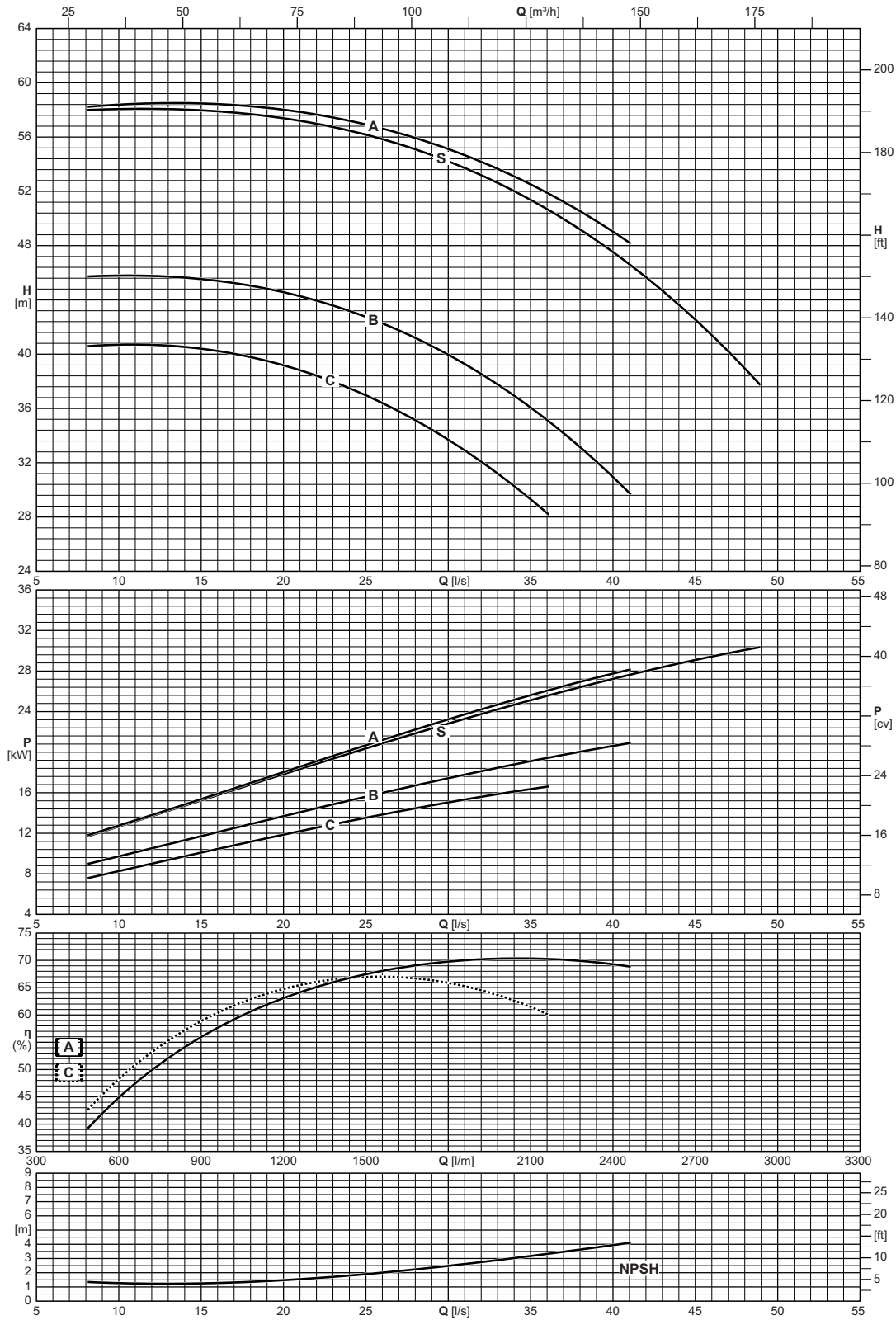

Type Тип Tipo	Inlet maximum pressure Макс. давление на всасывании Pressione massima in aspirazione
NCD4P80-400	[bar] 16

Operating data
Рабочие характеристики
Caratteristiche di funzionamento

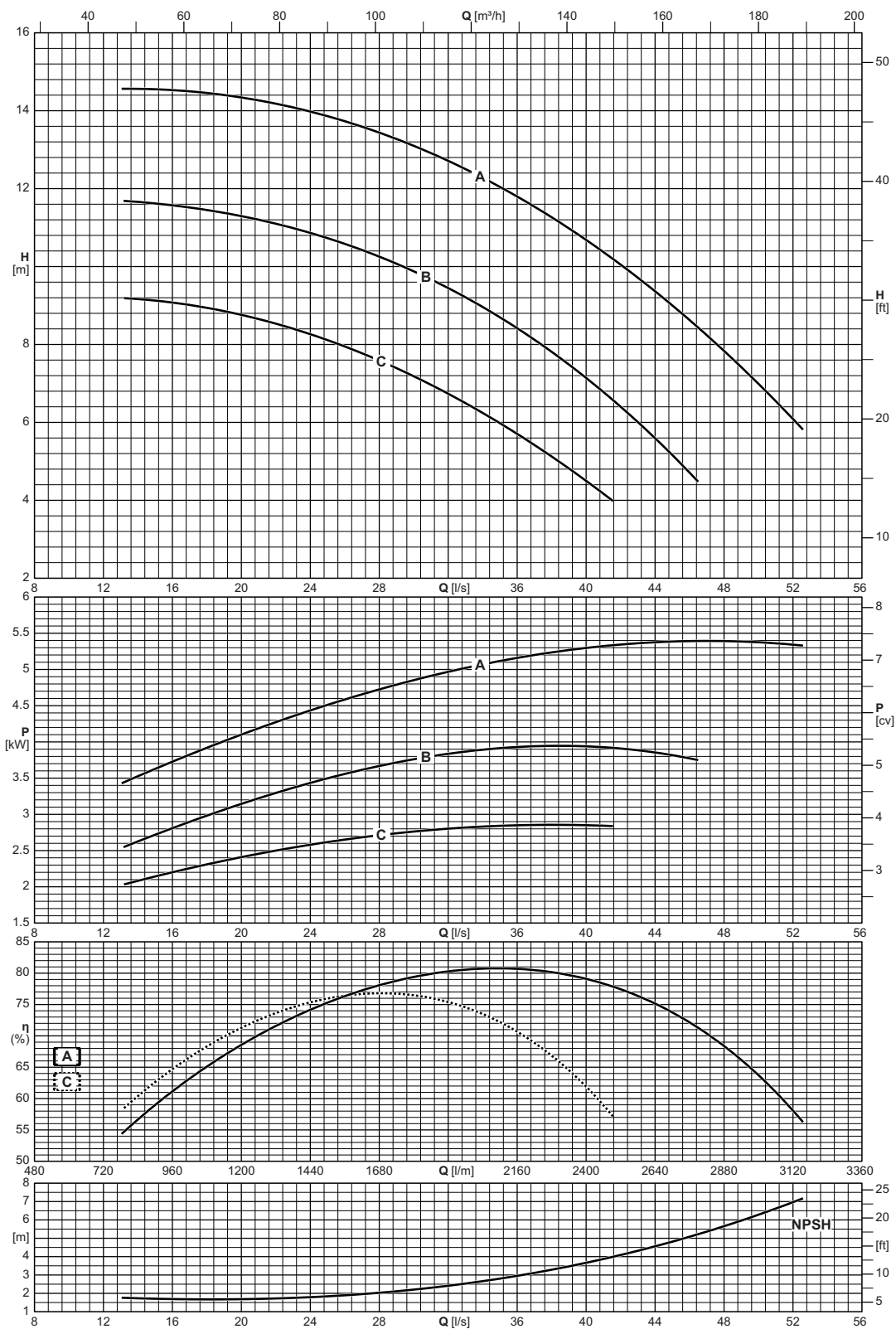

Type <i>Tun</i> Tipo	Inlet maximum pressure <i>Макс. давление на всасывании</i> Pressione massima in aspirazione
NCD4P100-200	[bar] 16

NCD 4P100-250

1450 n [min⁻¹]

ErP Ready



Operating data
Рабочие характеристики
Caratteristiche di funzionamento

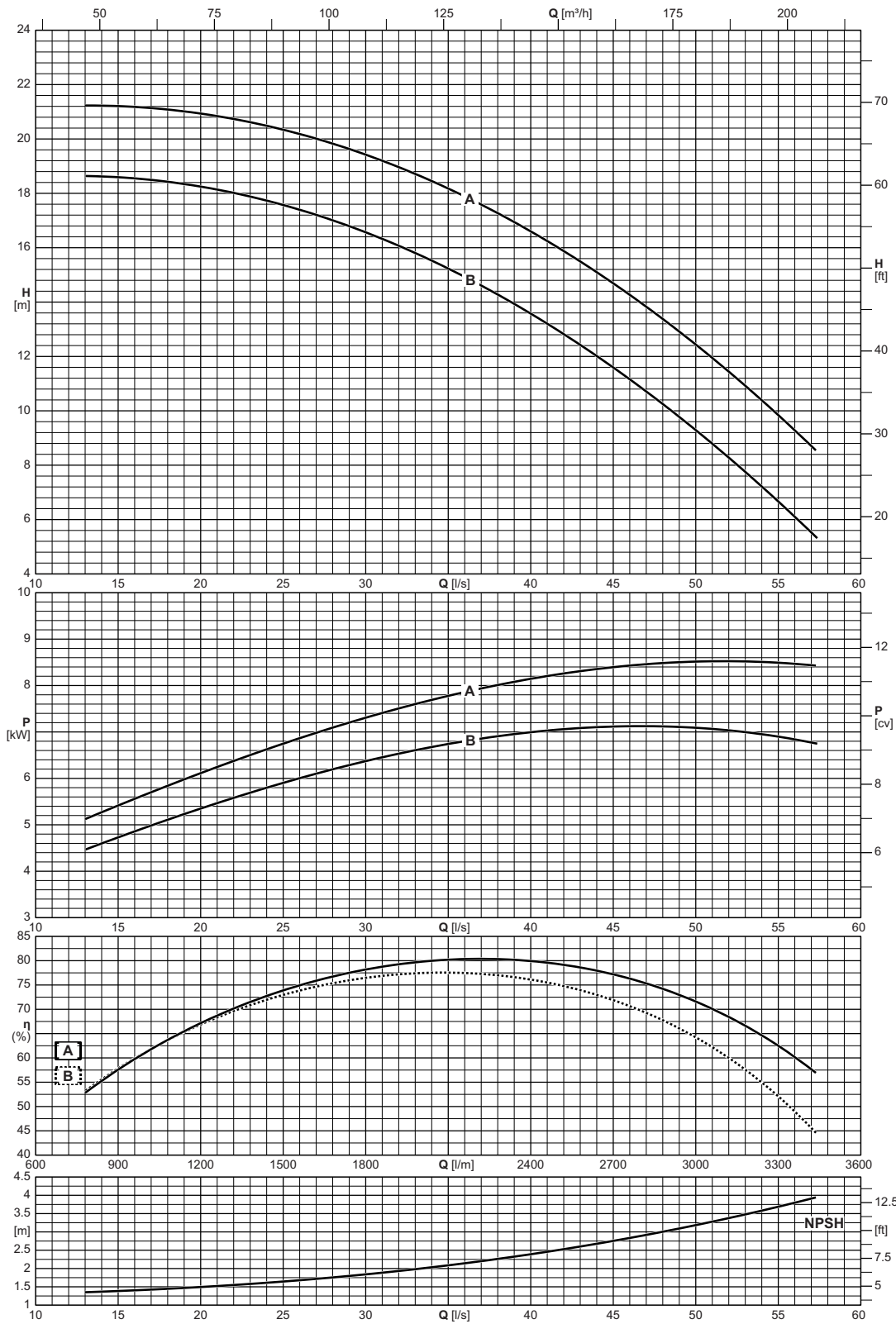

Type Тип Tipo	Inlet maximum pressure Макс. давление на всасывании Pressione massima in aspirazione
NCD4P100-250	[bar] 10

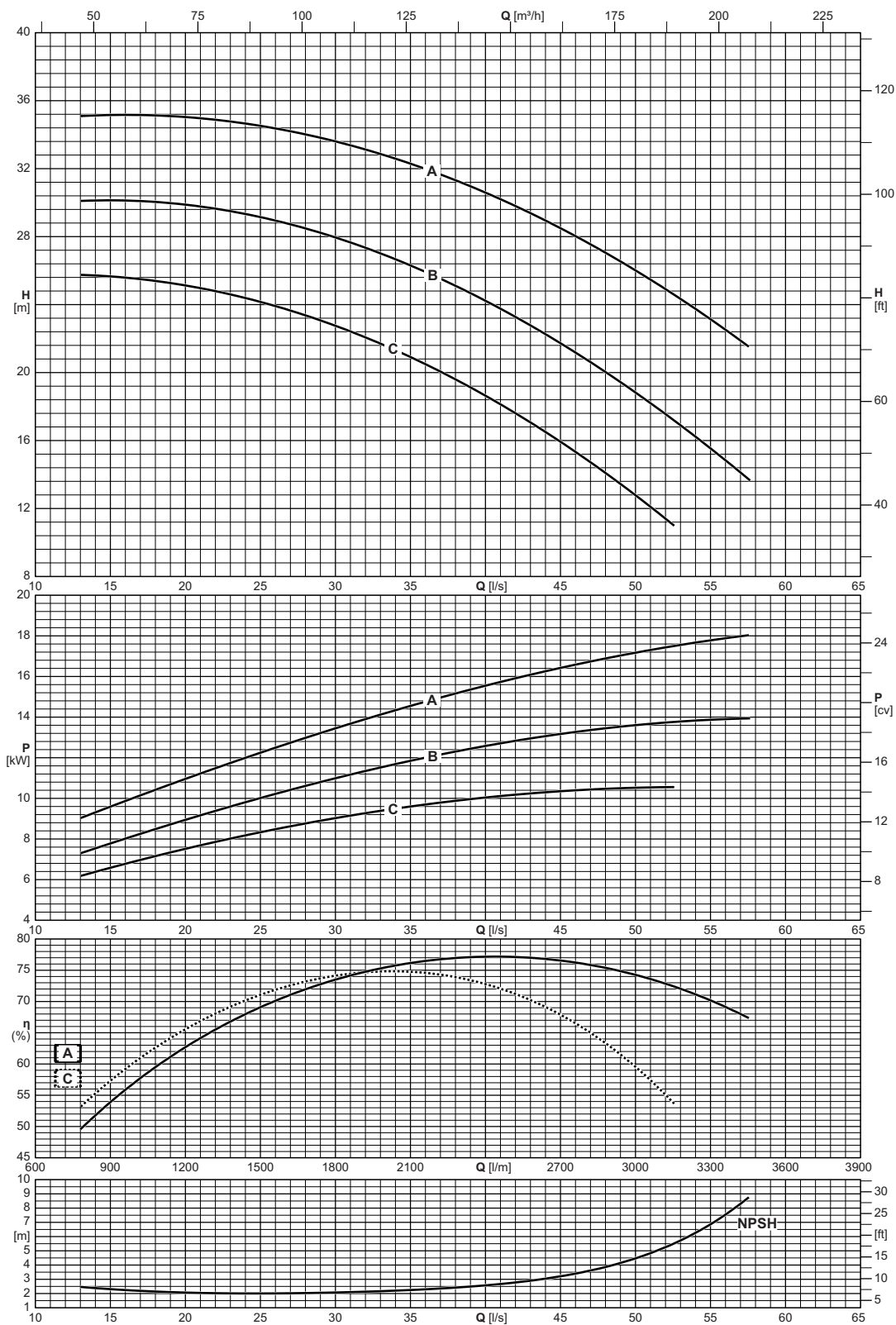

Type Тип Tipo	Inlet maximum pressure Макс. давление на всасывании Pressione massima in aspirazione
NCD4P100-315	[bar] 10

NCD 4P100-400

1450 n [min⁻¹]

ErP Ready



Operating data
Рабочие характеристики
Caratteristiche di funzionamento

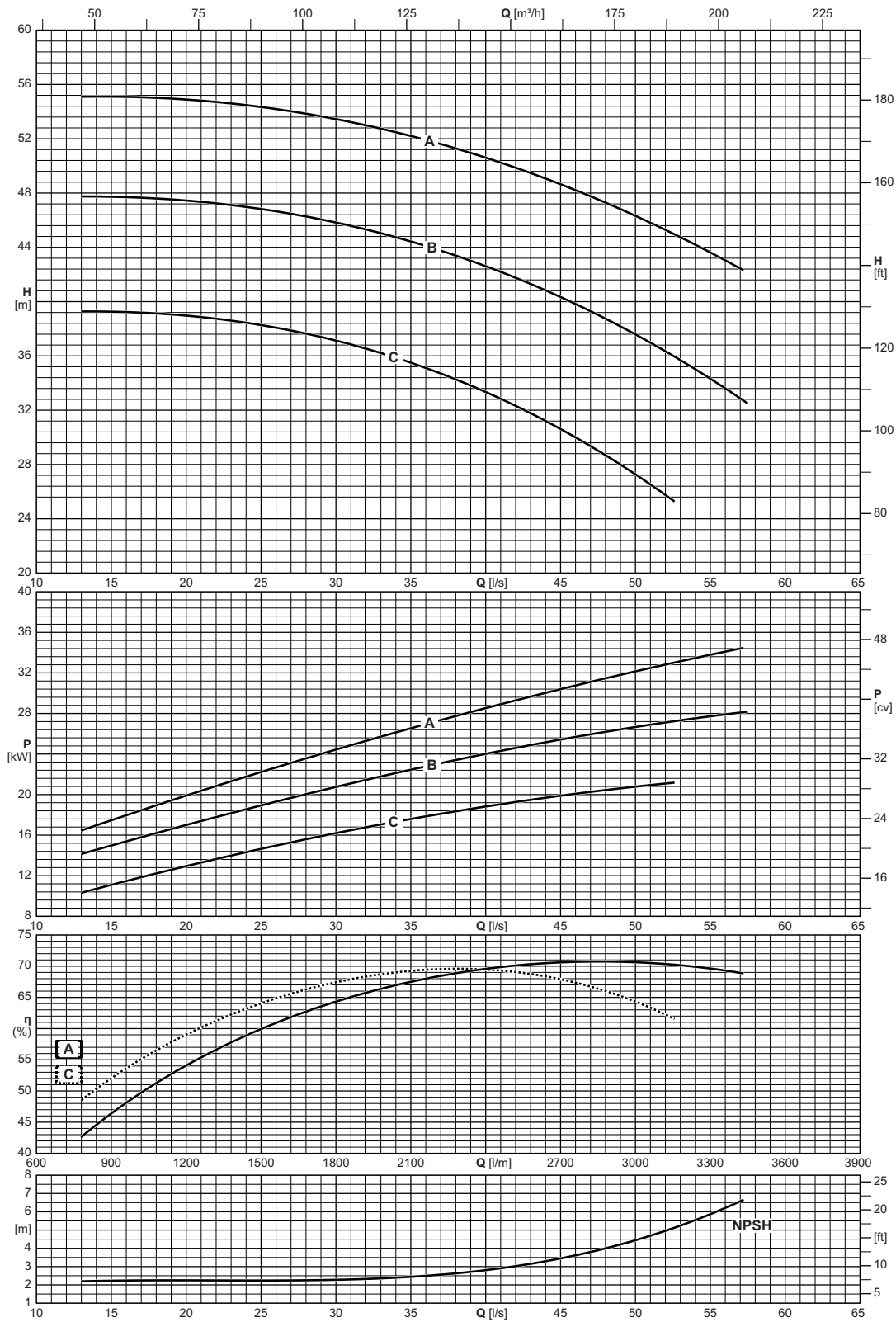

Type Тип Tipo	Inlet maximum pressure Макс. давление на всасывании Pressione massima in aspirazione [bar]
NCD4P100-400	10

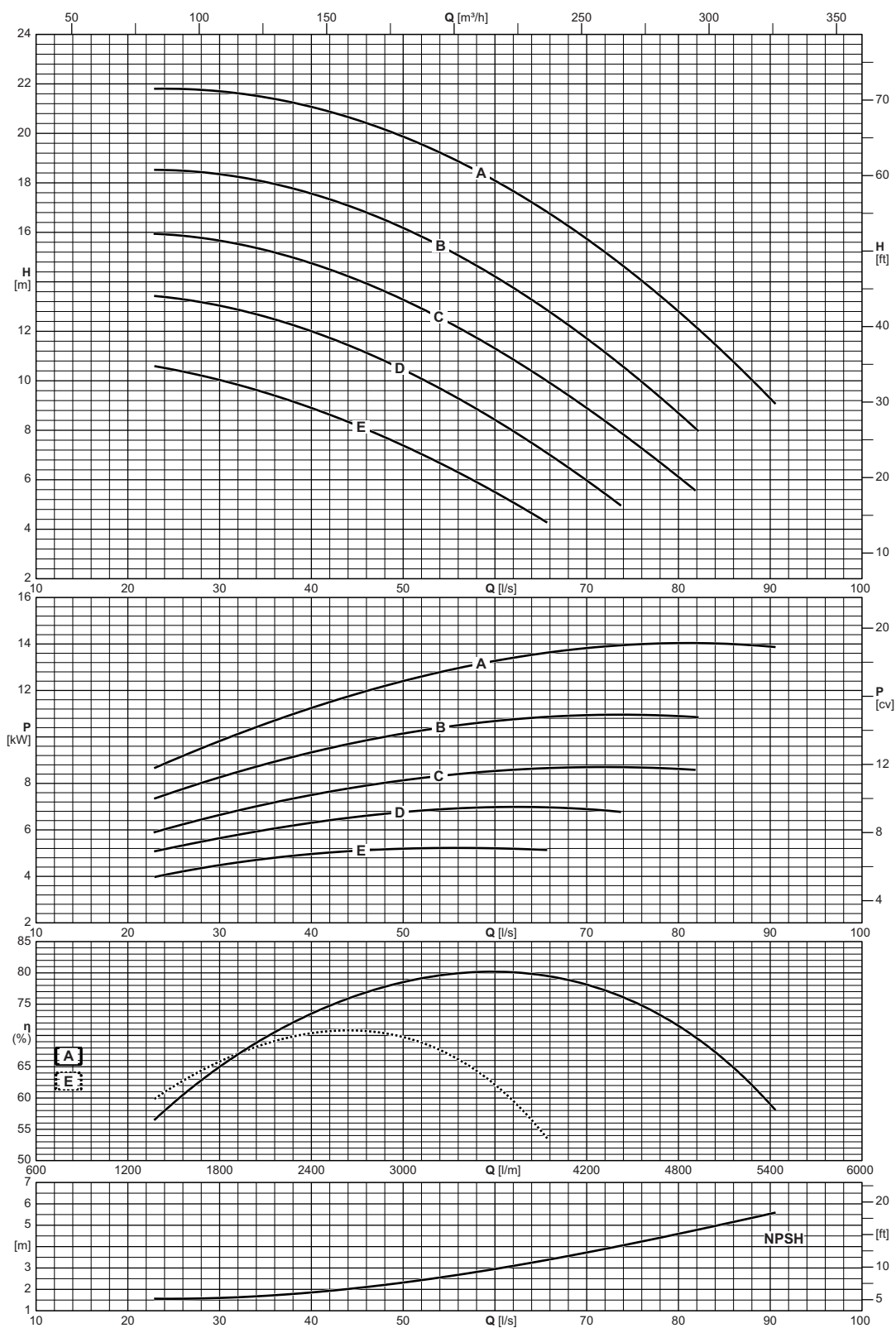

Type Тип Tipo	Inlet maximum pressure Макс. давление на всасывании Pressione massima in aspirazione
NCD4P125-250	[bar] 10

NCD 4P125-315

1450 n [min⁻¹]

ErP Ready



Operating data
Рабочие характеристики
Caratteristiche di funzionamento

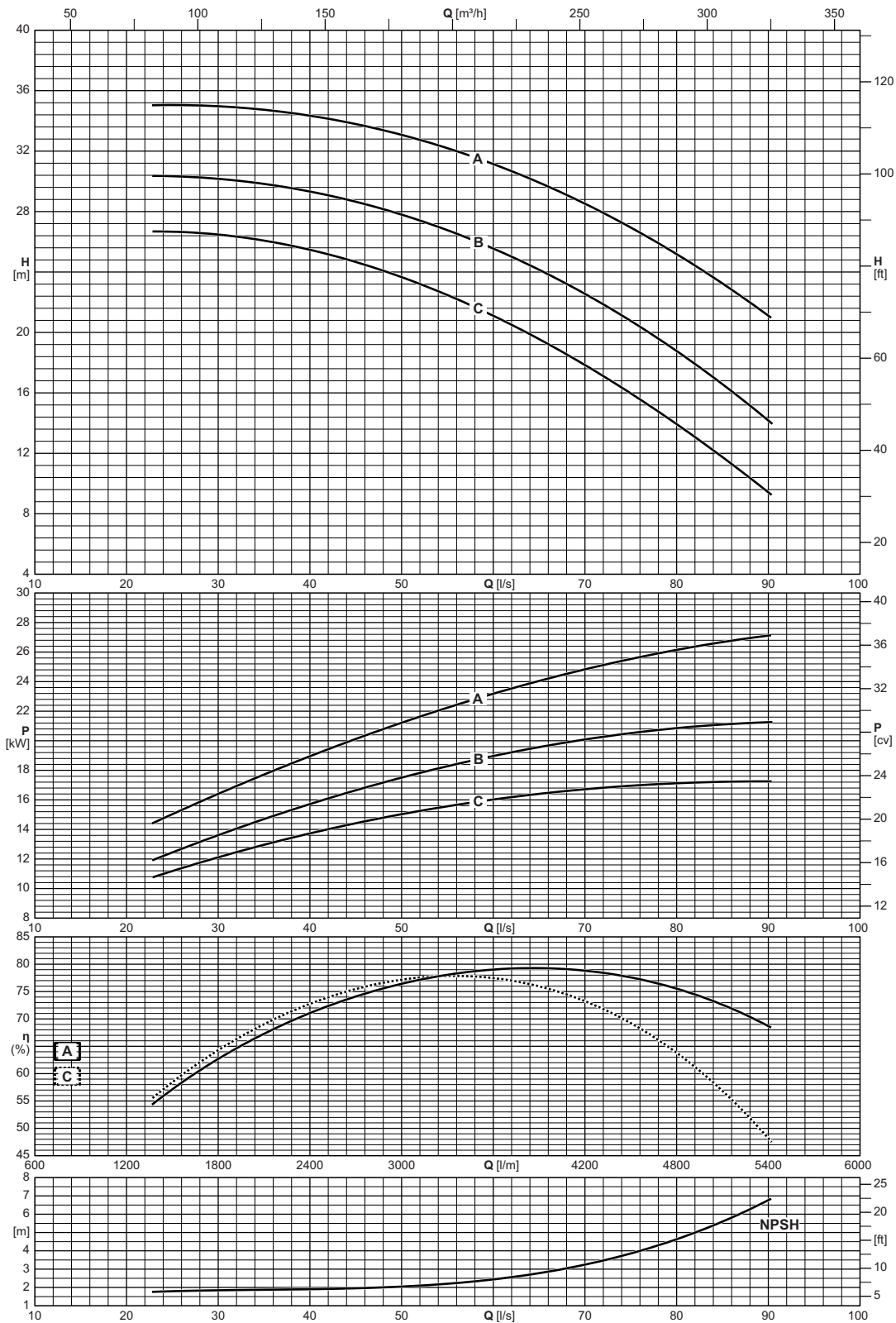

Type Тип Tipo	Inlet maximum pressure Макс. давление на всасывании Pressione massima in aspirazione [bar]
NCD4P125-315	16

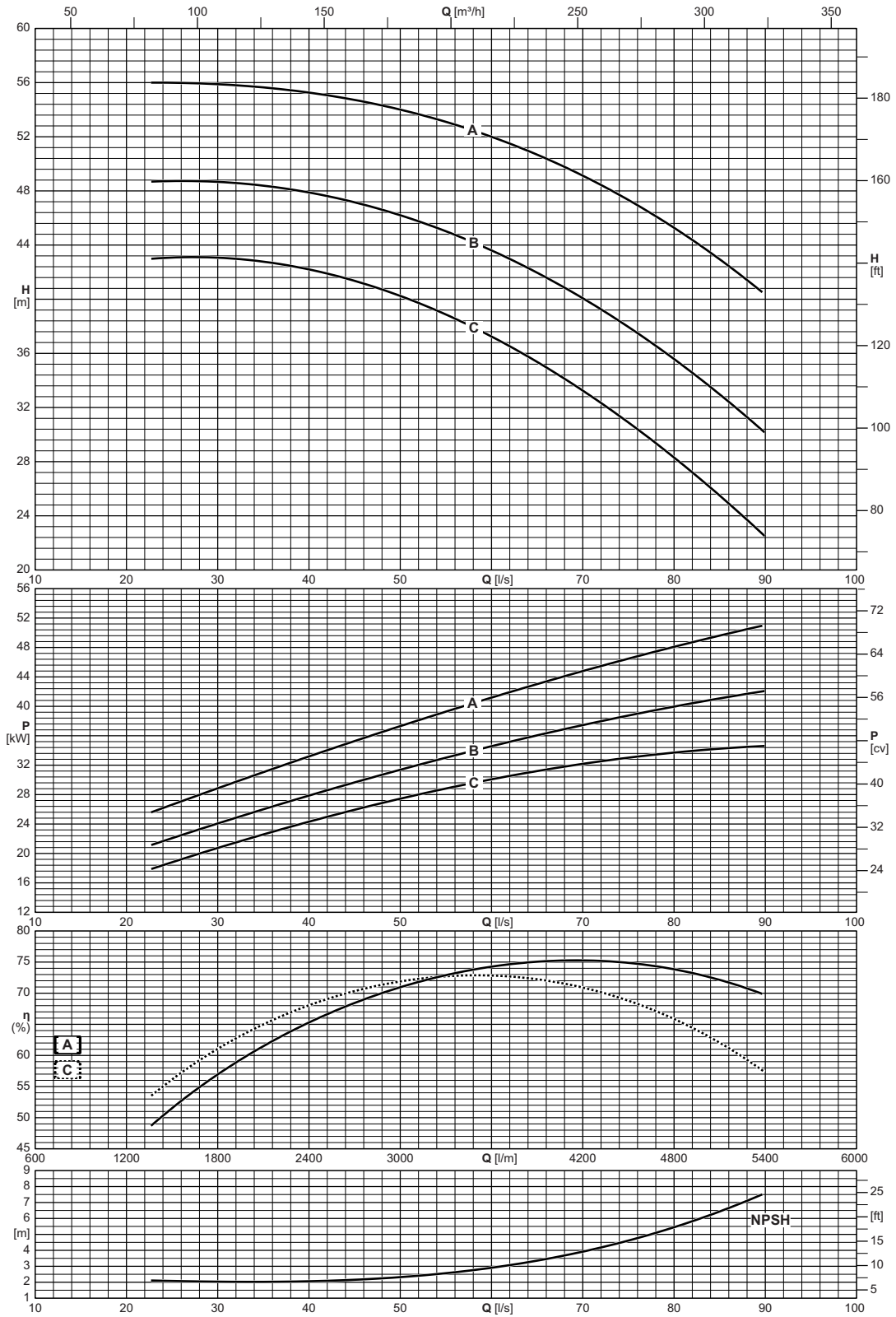

Type Тип Tipo	Inlet maximum pressure Макс. давление на всасывании Pressione massima in aspirazione
NCD4P125-400	[bar] 10

NCD 4P150-315

1450 n [min⁻¹]

ErP Ready



Operating data
Рабочие характеристики
Caratteristiche di funzionamento

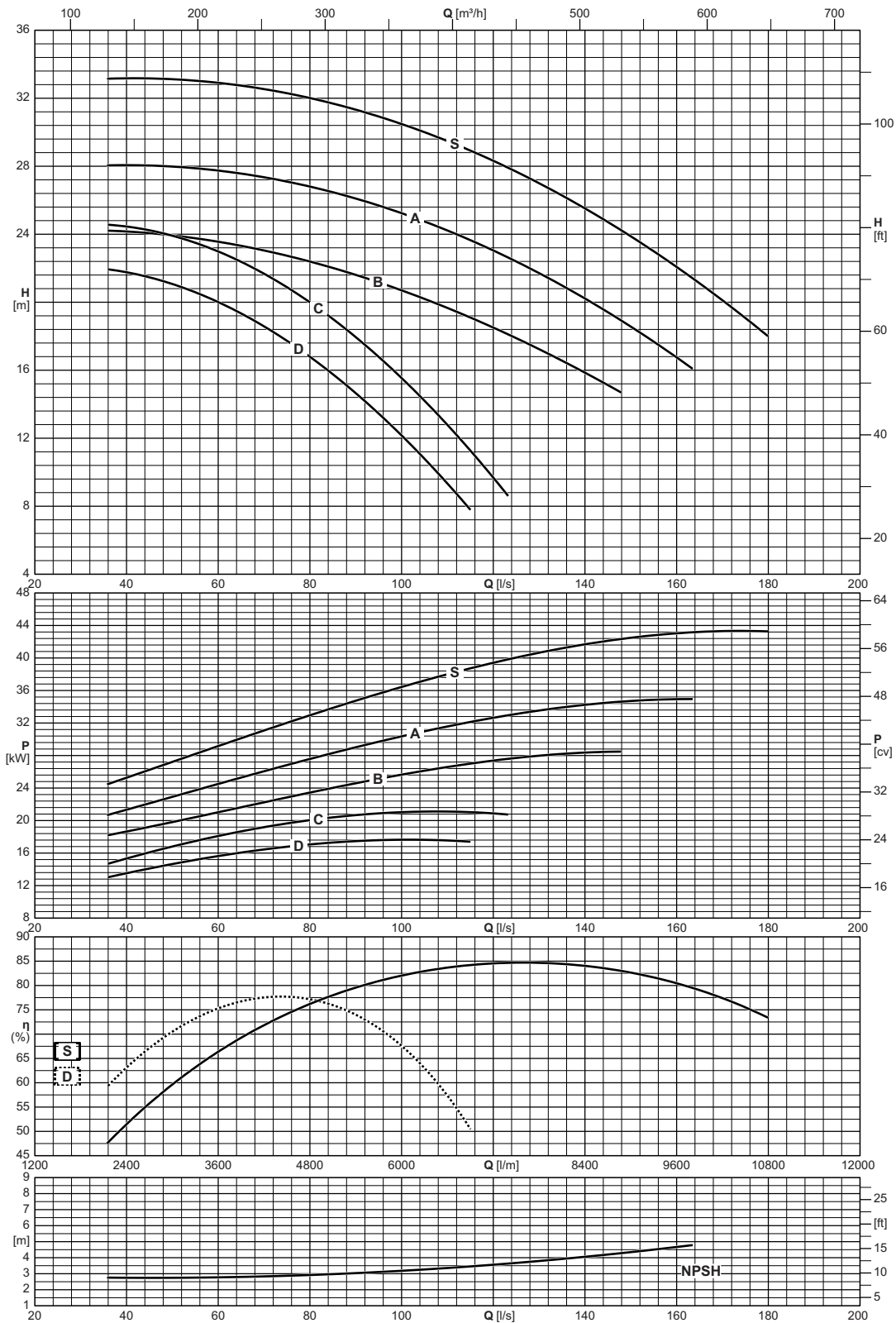

Type Тип Tipo	Inlet maximum pressure Макс. давление на всасывании Pressione massima in aspirazione
NCD4P150-315	[bar] 10

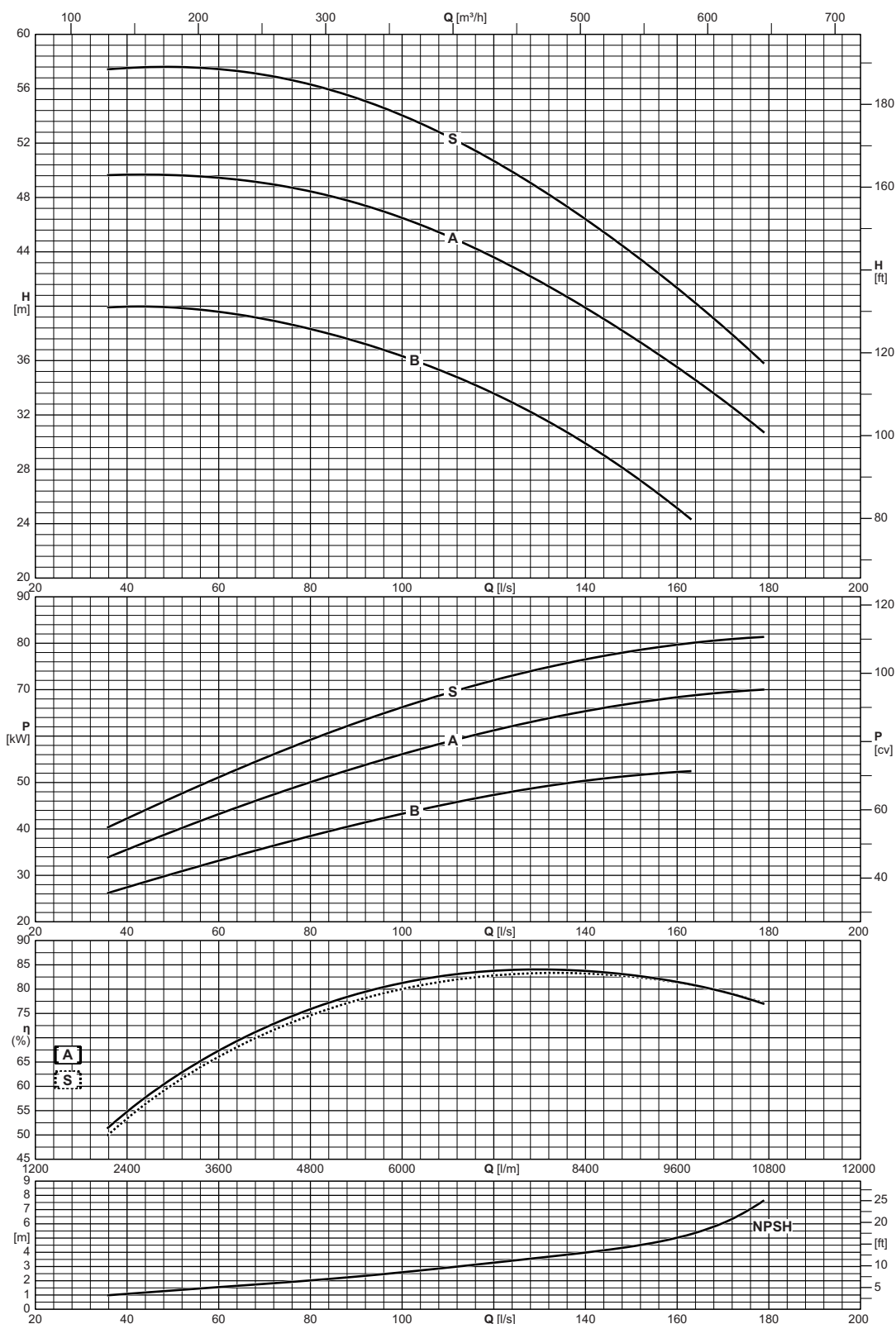

Type Тип Tipo	Inlet maximum pressure Макс. давление на всасывании Pressione massima in aspirazione
NCD4P150-400	[bar] 10

NCD 4P200-315

1450 n [min⁻¹]



Operating data
Рабочие характеристики
Caratteristiche di funzionamento

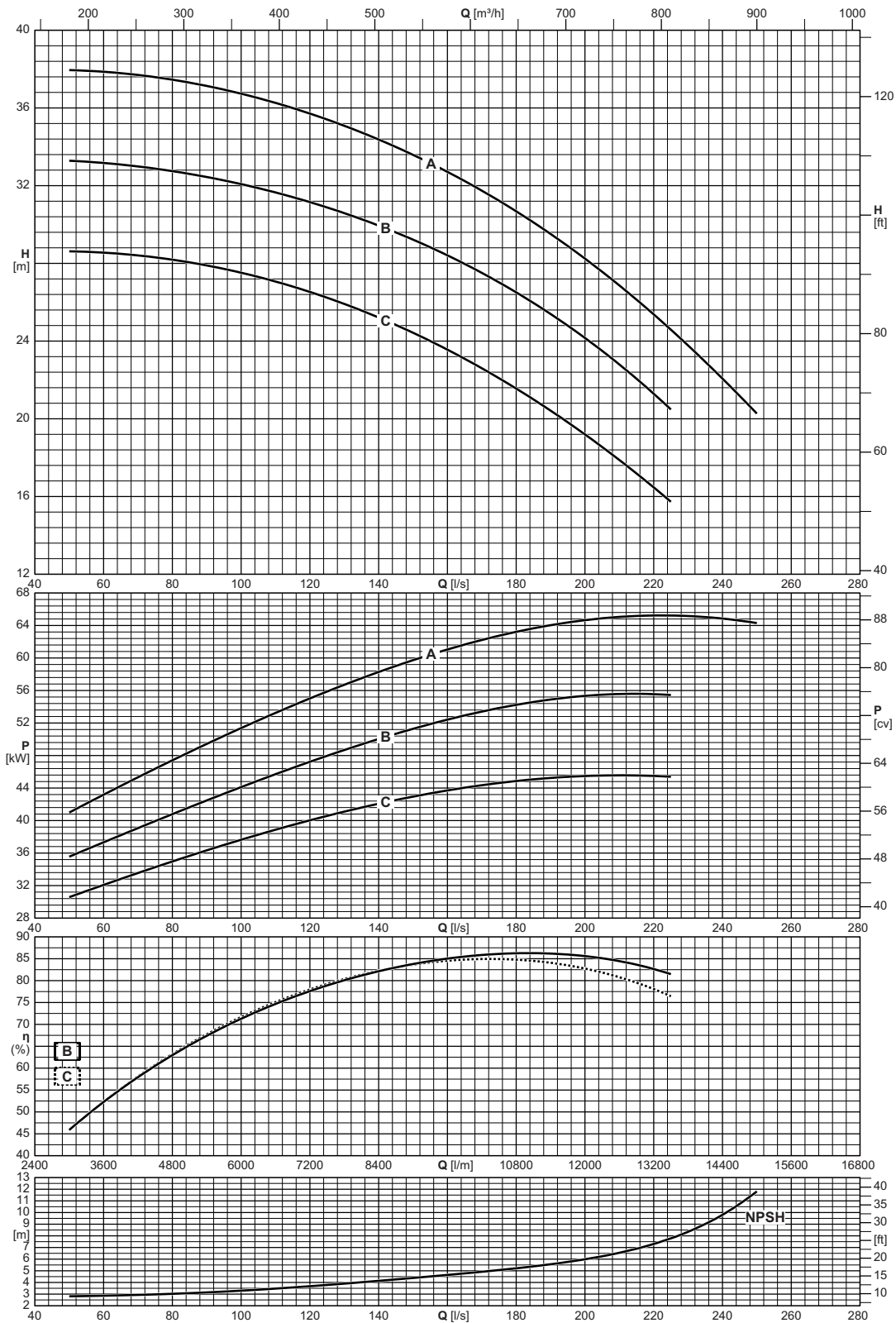

Type Тип Tipo	Inlet maximum pressure Макс. давление на всасывании Pressione massima in aspirazione
	[bar]
NCD4P200-315	16

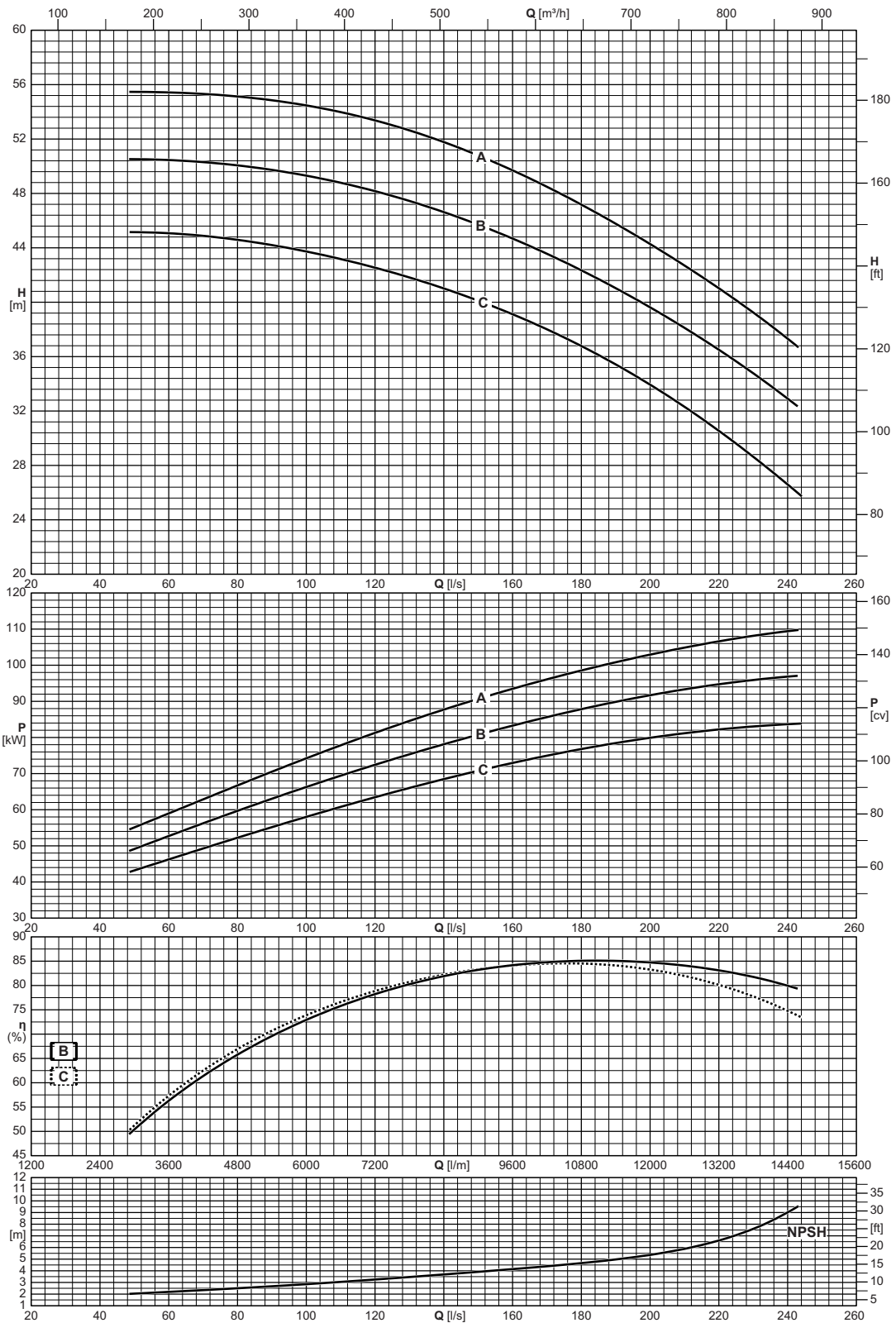

Type <i>Tun</i> Tipo	Inlet maximum pressure <i>Макс. давление на всасывании</i> Pressione massima in aspirazione
NCD4P200-400	[bar] 16

Operating data
Рабочие характеристики
Caratteristiche di funzionamento

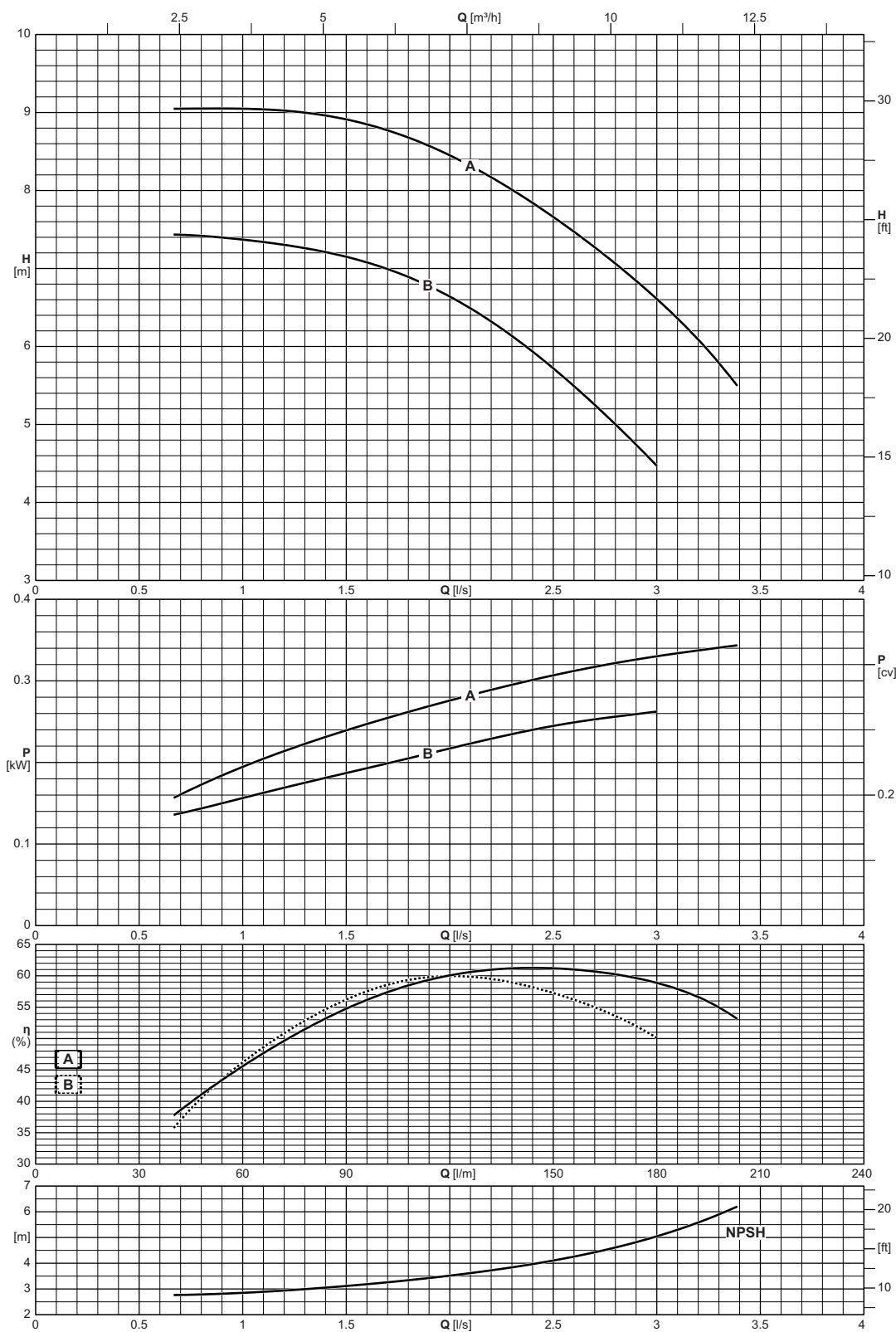

Type Тип Tipo	Inlet maximum pressure Макс. давление на всасывании Pressione massima in aspirazione
NCDS4P32-160	[bar] 10

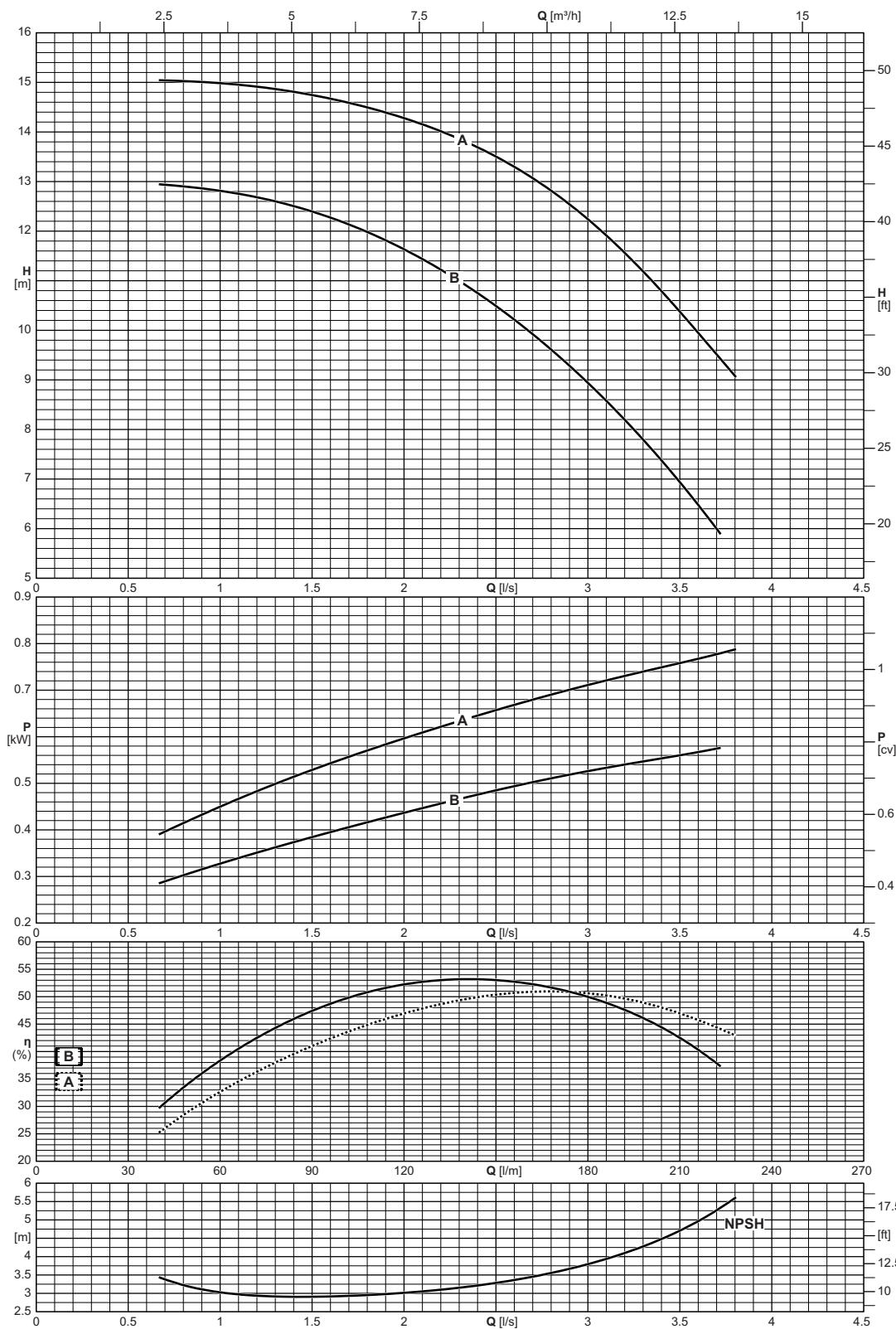

Type <i>Tun</i> Tipo	Inlet maximum pressure <i>Макс. давление на всасывании</i> Pressione massima in aspirazione
NCDS4P32-200	[bar] 10

NCDS 4P40-160

1750 n [min⁻¹]

ErP Ready



Operating data
Рабочие характеристики
Caratteristiche di funzionamento

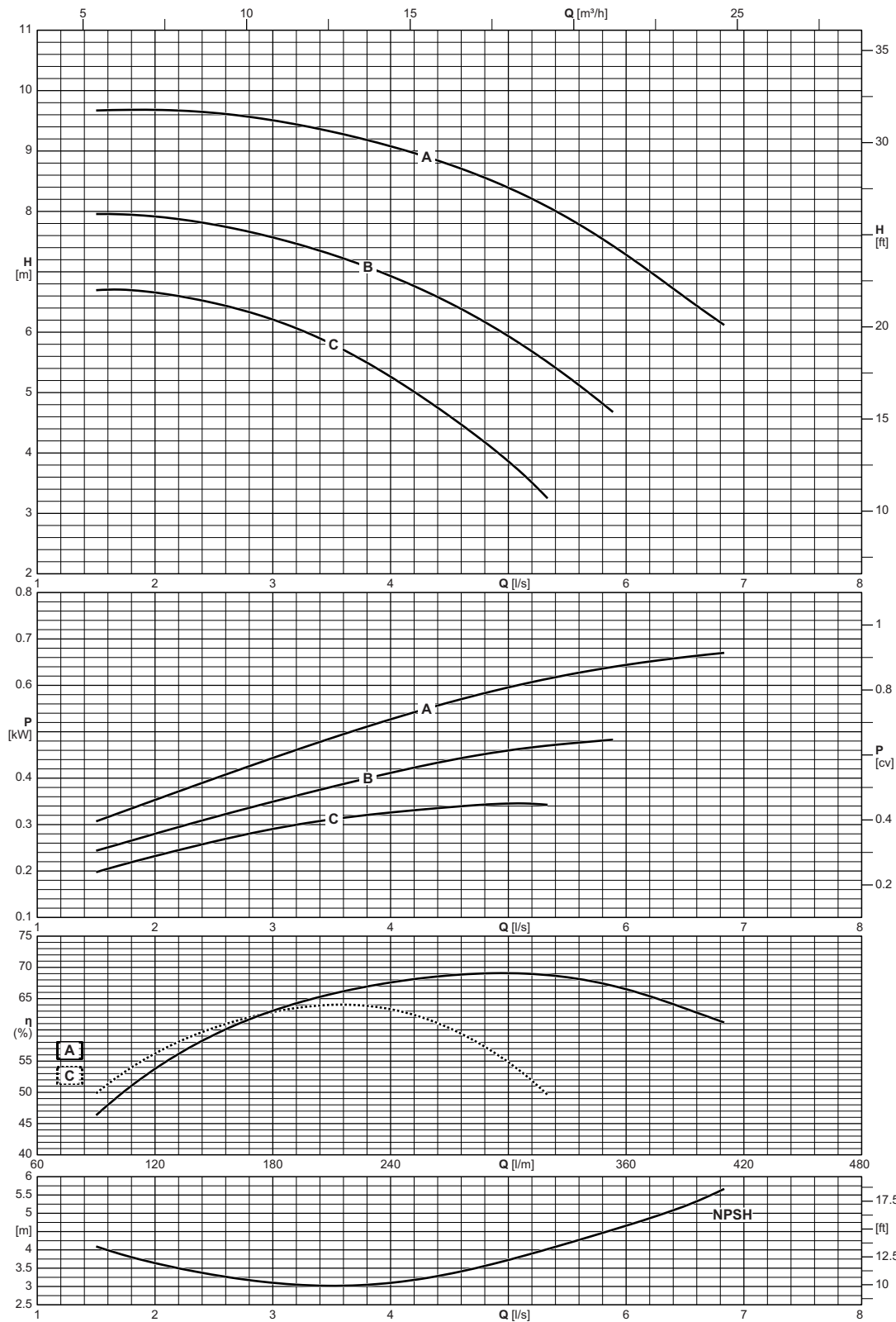

Type Тип Tipo	Inlet maximum pressure Макс. давление на всасывании Pressione massima in aspirazione
NCDS4P40-160	[bar] 16

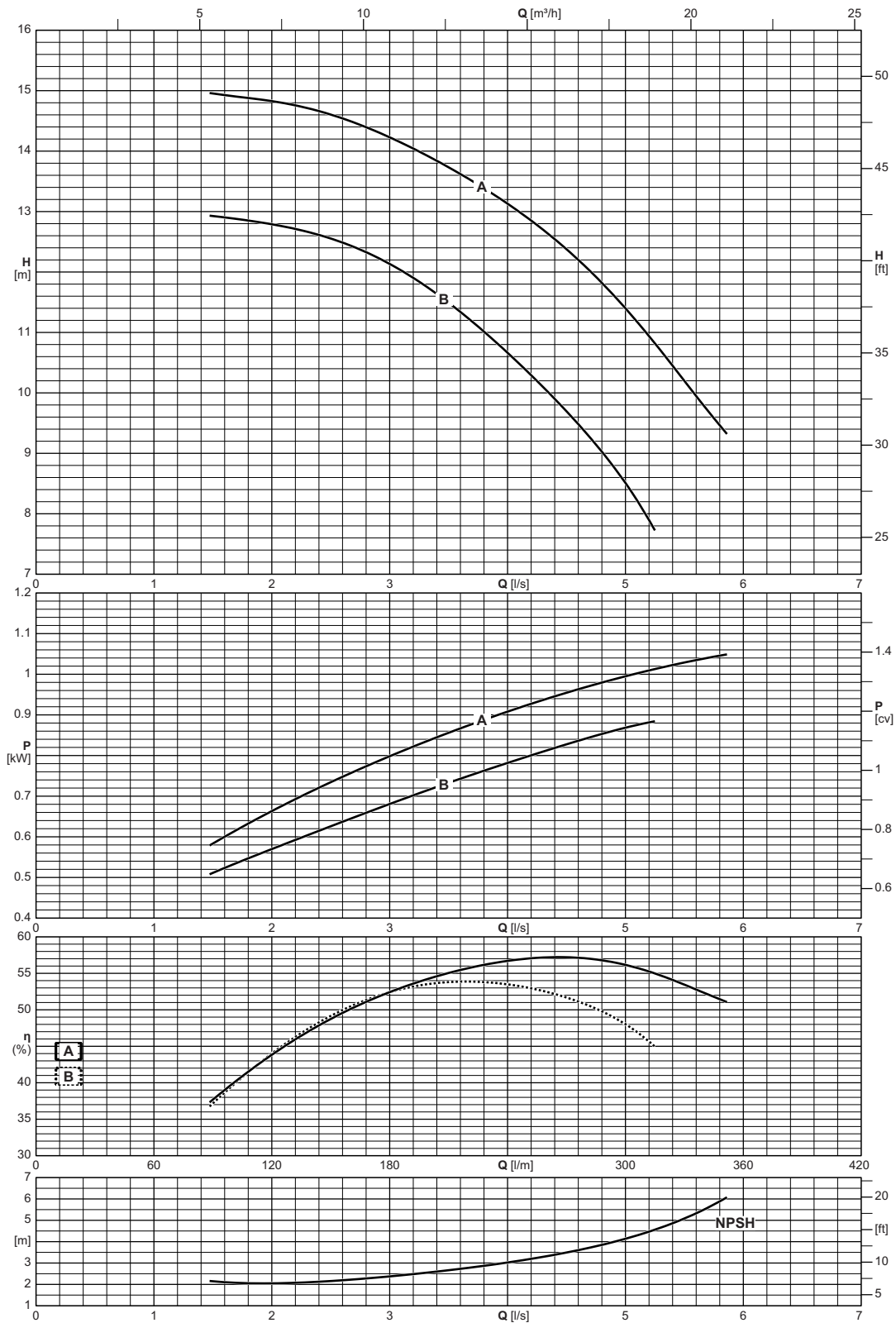

Type <i>Tun</i> Tipo	Inlet maximum pressure <i>Макс. давление на всасывании</i> Pressione massima in aspirazione [bar]
NCDS4P40-200	16

NCDS 4P40-250

1750 n [min⁻¹]

ErP Ready



Operating data
Рабочие характеристики
Caratteristiche di funzionamento

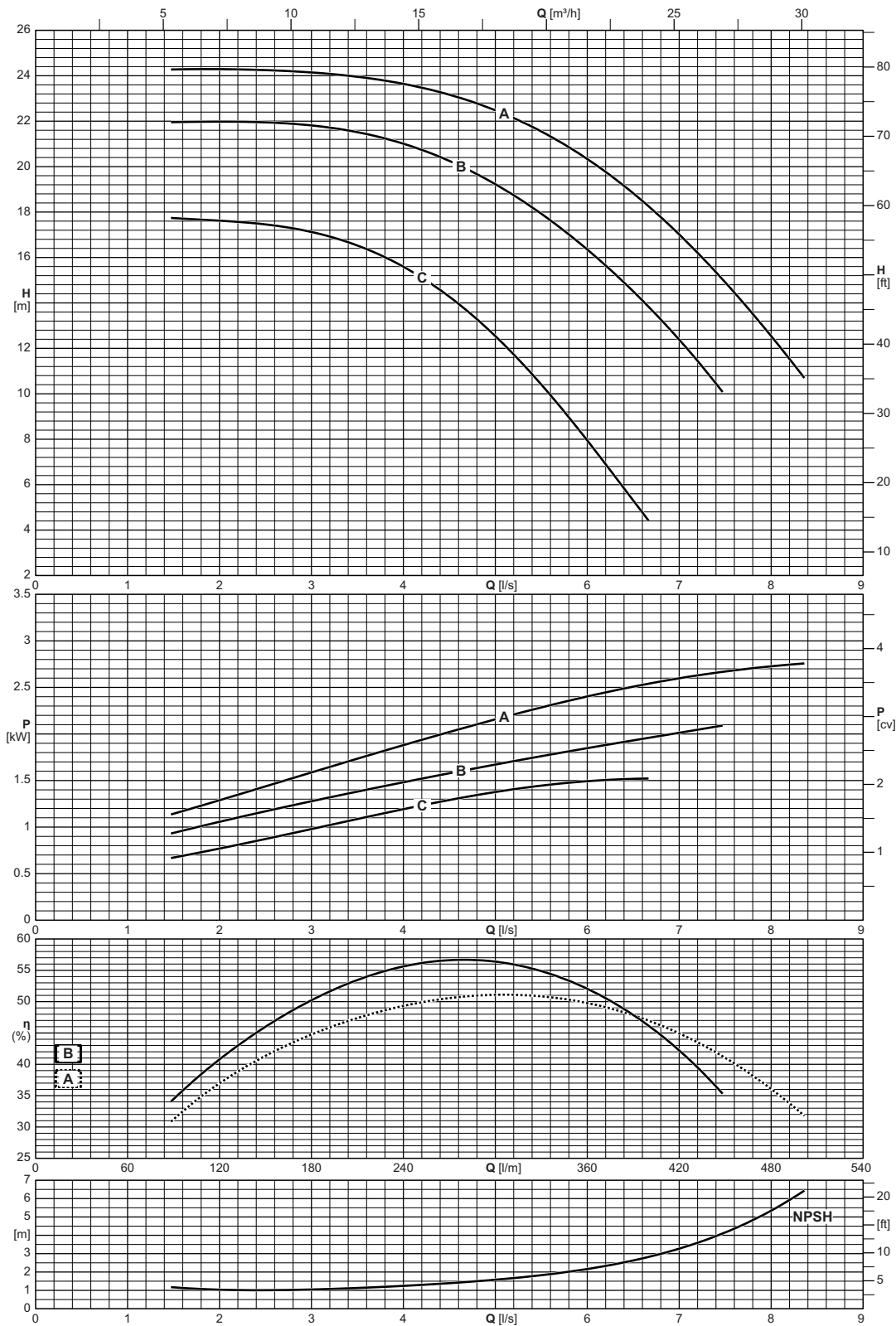

Type Тип Tipo	Inlet maximum pressure Макс. давление на всасывании Pressione massima in aspirazione
NCDS4P40-250	[bar] 10

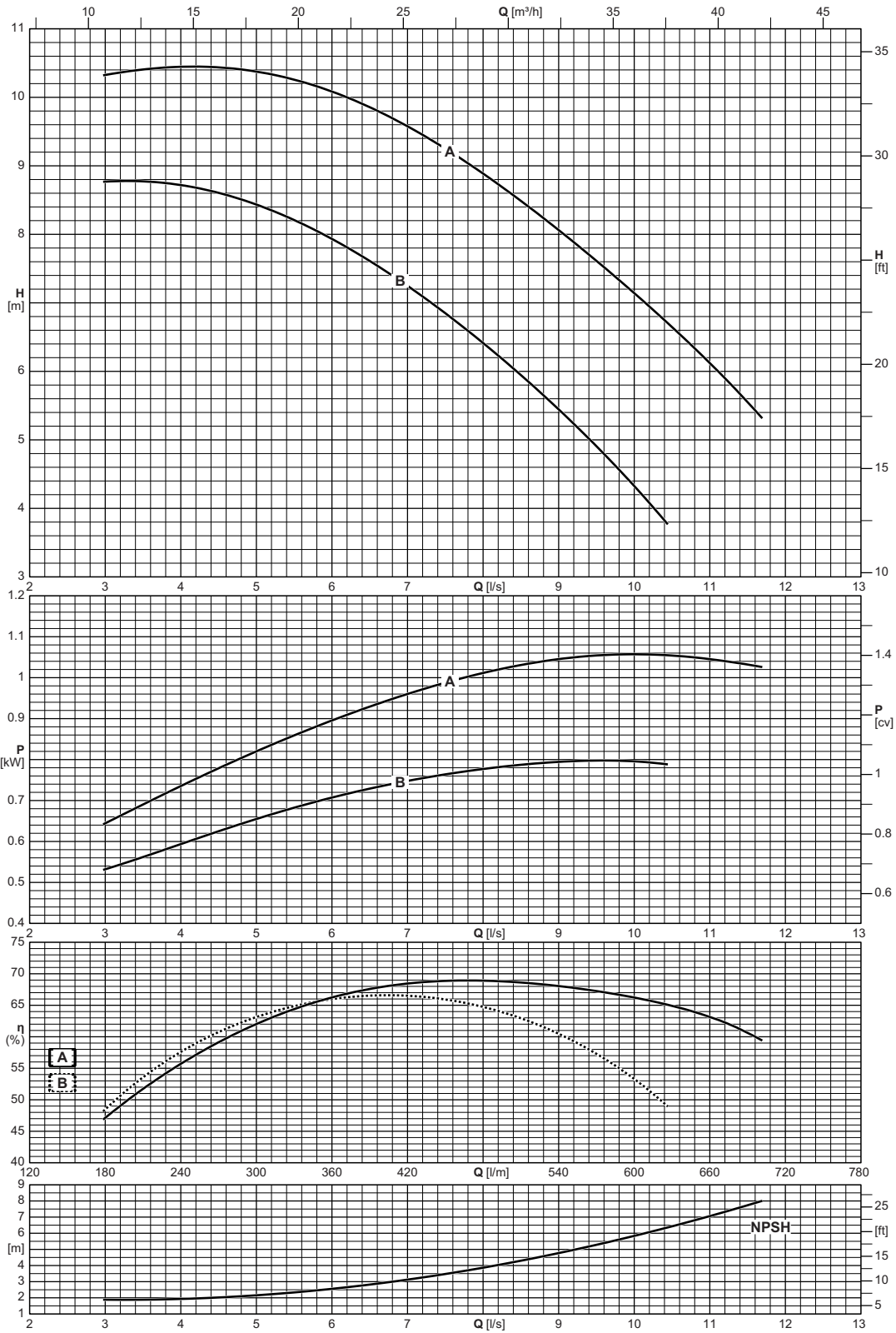

Type Тип Tipo	Inlet maximum pressure Макс. давление на всасывании Pressione massima in aspirazione
NCDS4P50-160	[bar] 16

NCDS 4P50-200

1750 n [min⁻¹]

ErP Ready



Operating data
Рабочие характеристики
Caratteristiche di funzionamento

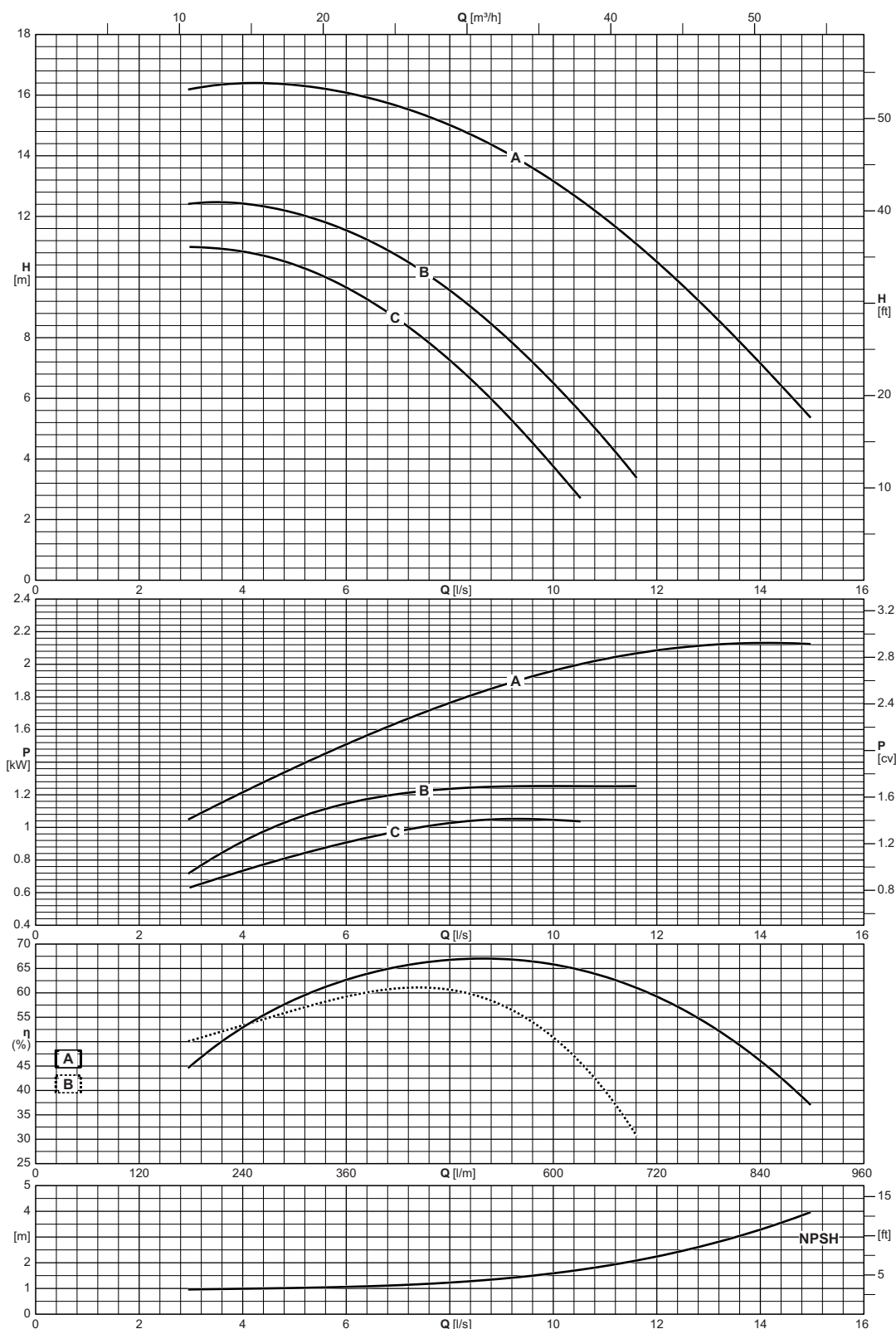

Type Тип Tipo	Inlet maximum pressure Макс. давление на всасывании Pressione massima in aspirazione
NCDS4P50-200	[bar] 10

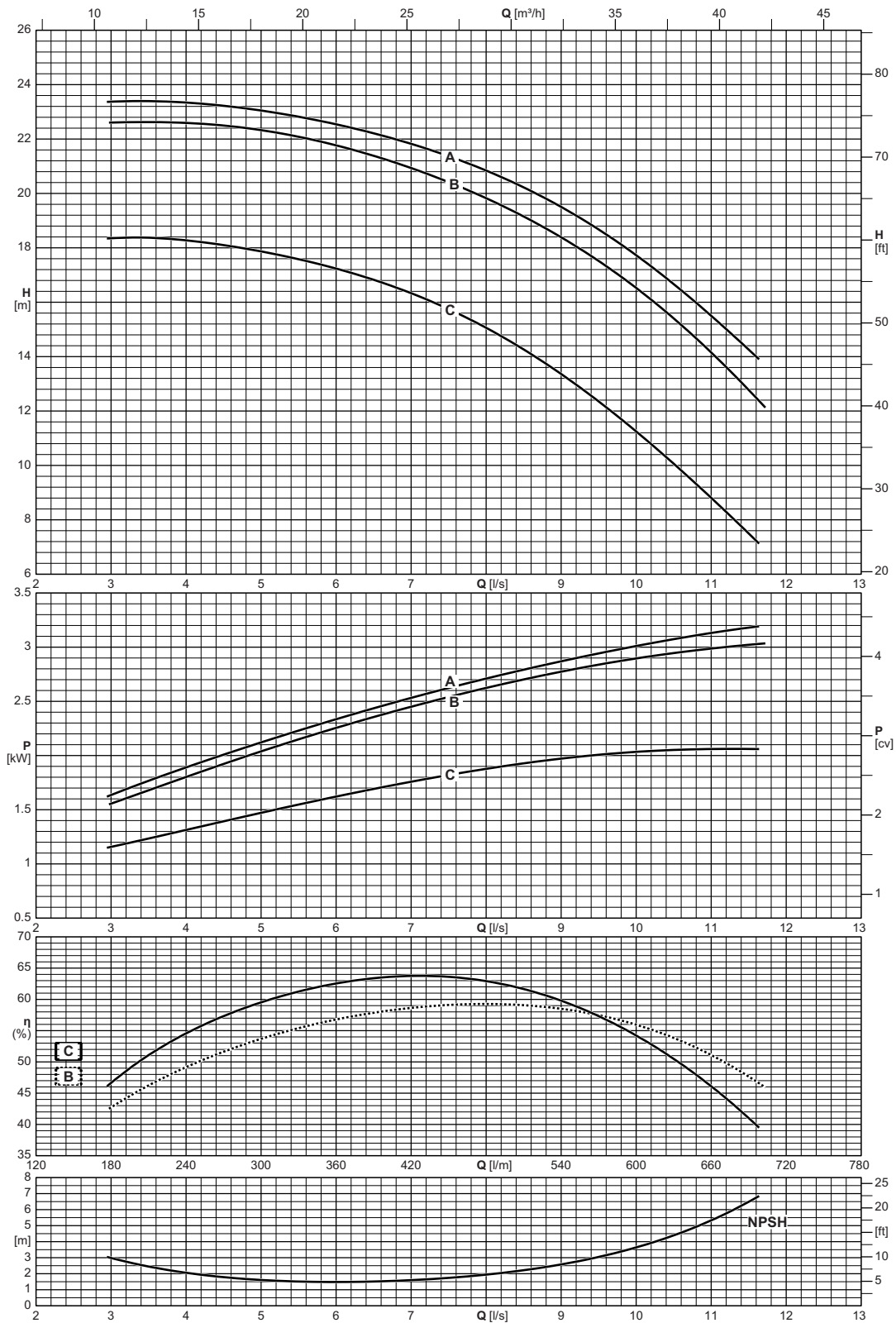

Type Тип Tipo	Inlet maximum pressure Макс. давление на всасывании Pressione massima in aspirazione
NCDS4P50-250	[bar] 10

NCDS 4P65-125

1750 n [min⁻¹]

ErP Ready



Operating data
Рабочие характеристики
Caratteristiche di funzionamento

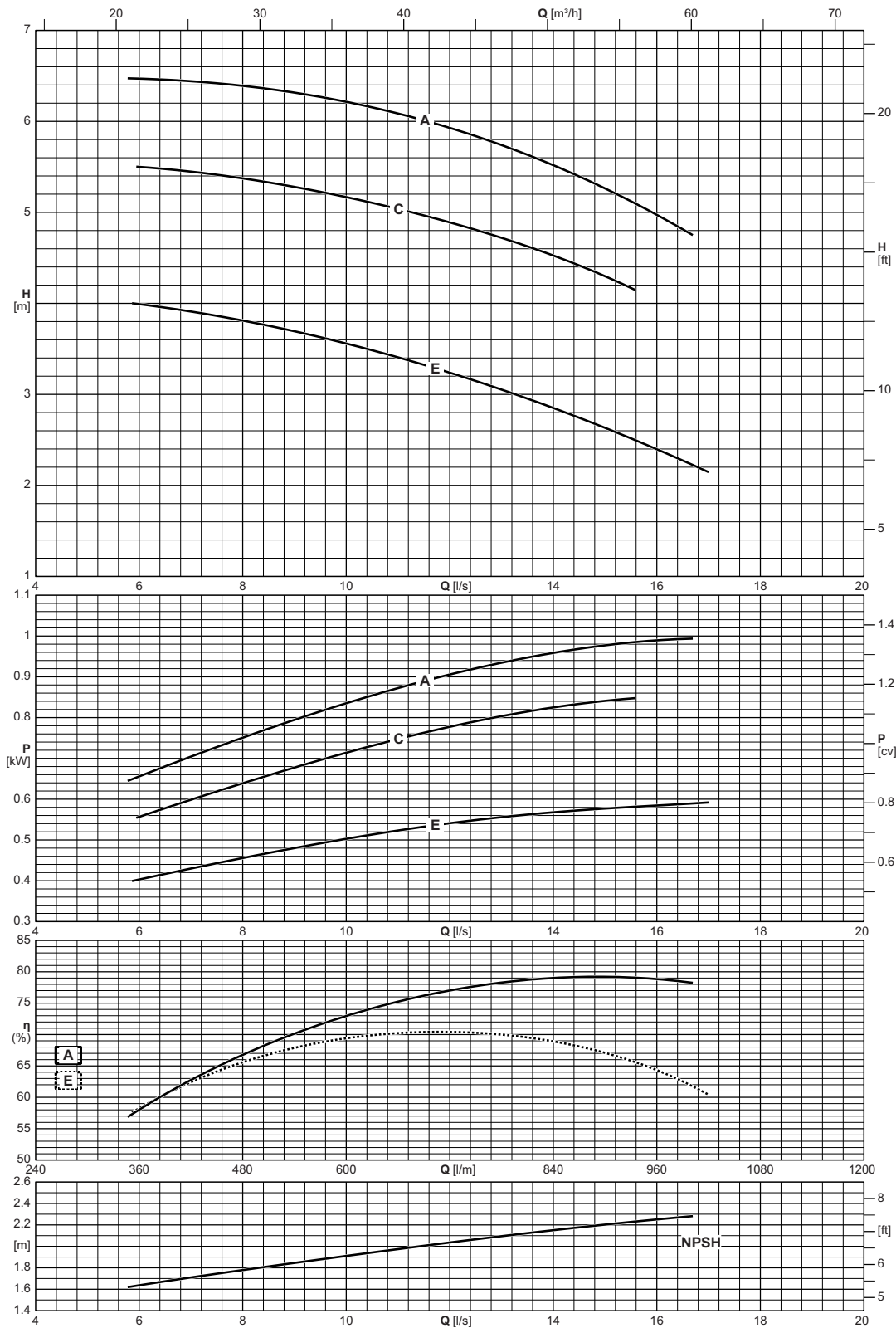

Type Тип Tipo	Inlet maximum pressure Макс. давление на всасывании Pressione massima in aspirazione
NCDS4P65-125	[bar] 16

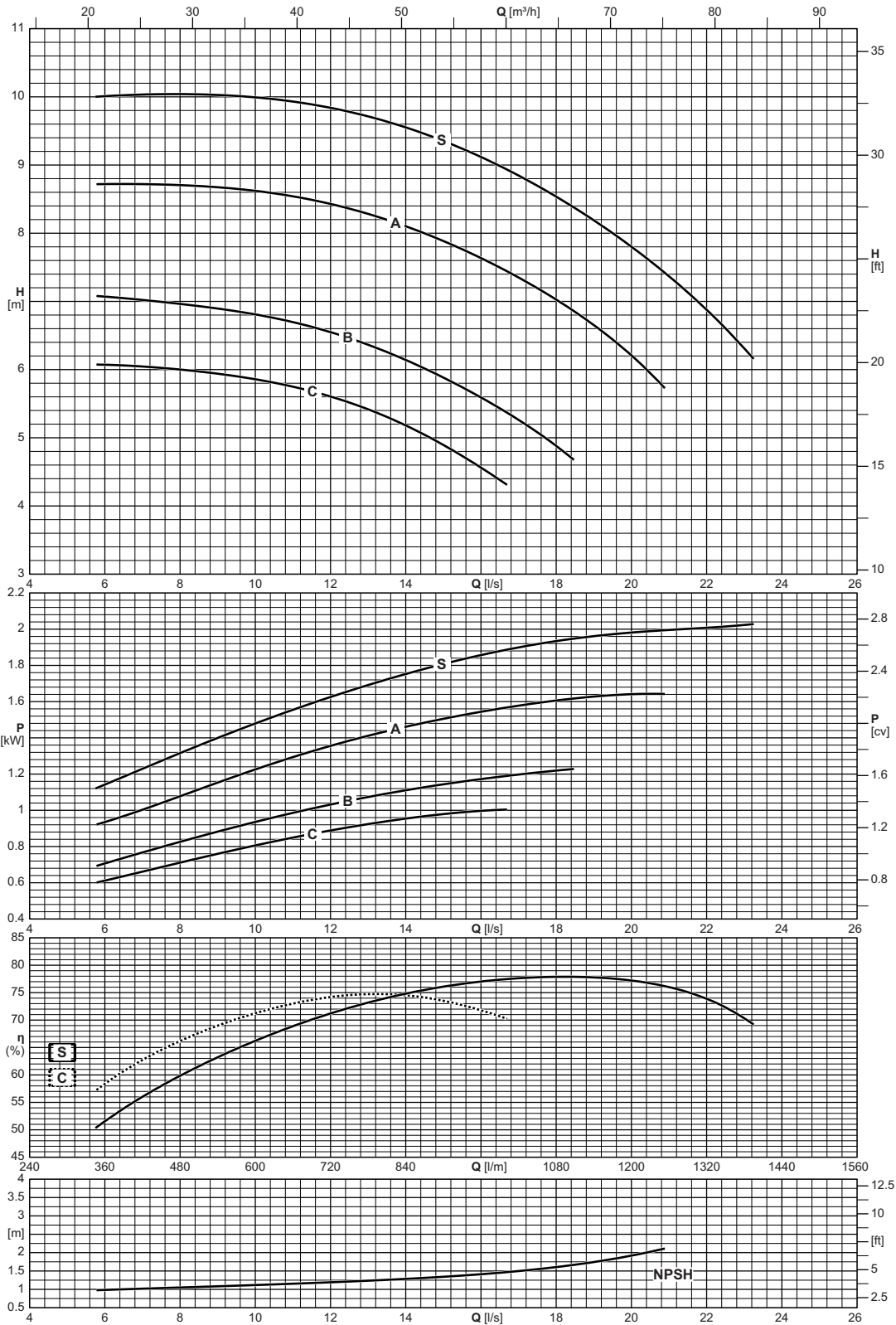

Type Тип Tipo	Inlet maximum pressure Макс. давление на всасывании Pressione massima in aspirazione
NCDS4P65-160	[bar] 16

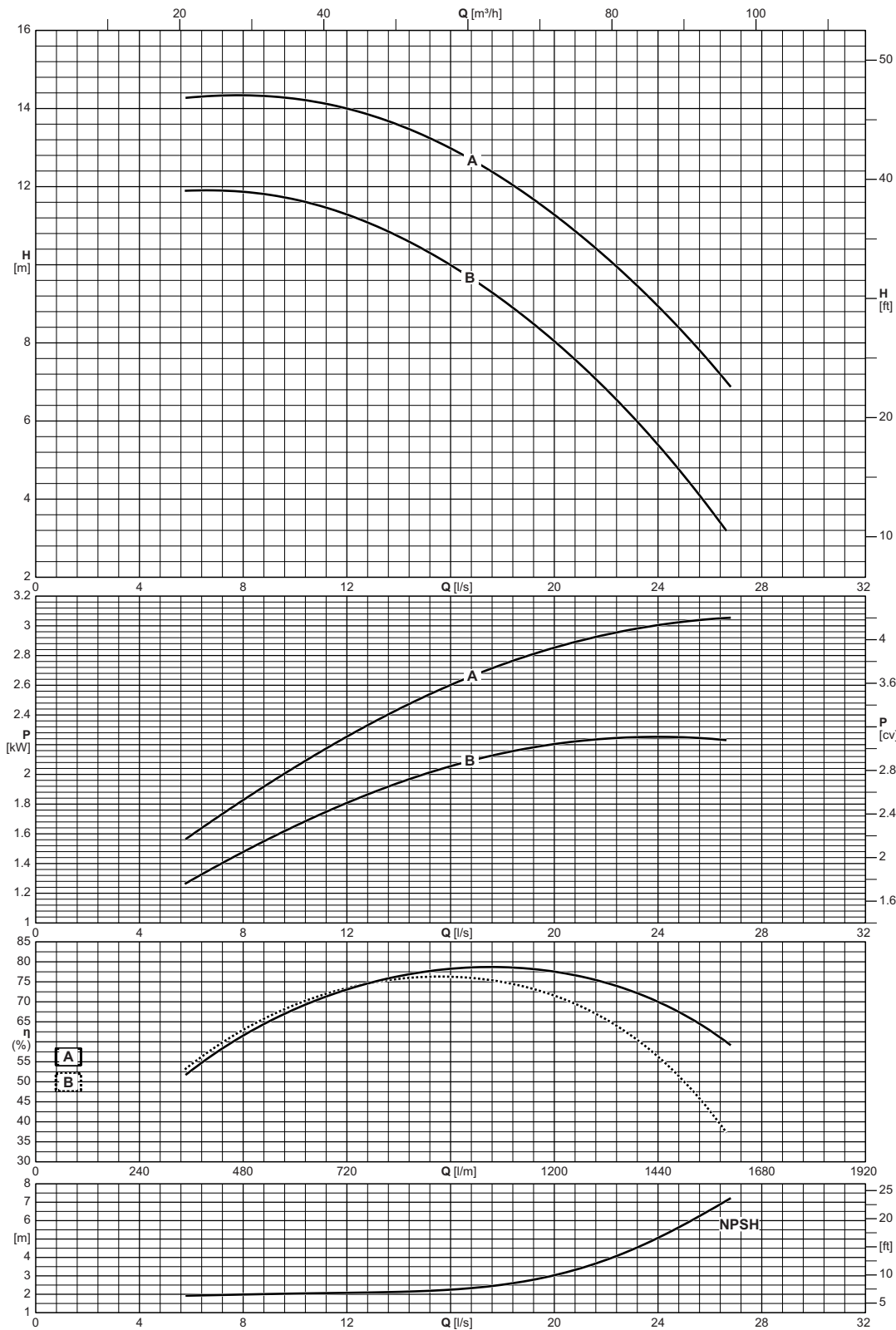

Type Тип Tipo	Inlet maximum pressure Макс. давление на всасывании Pressione massima in aspirazione
NCDS4P65-200	[bar] 16

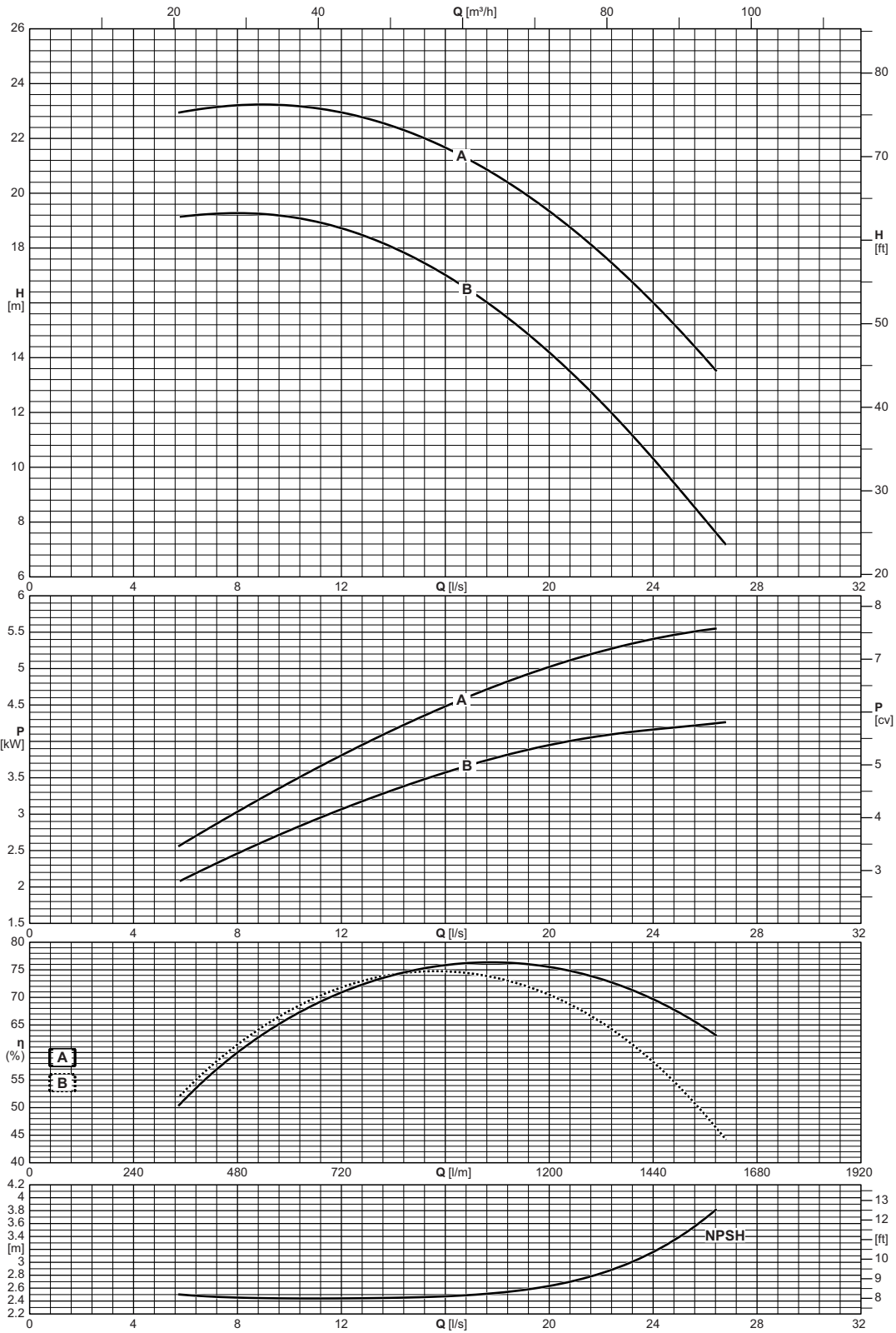

Type Тип Tipo	Inlet maximum pressure Макс. давление на всасывании Pressione massima in aspirazione
NCDS4P65-250	[bar] 16

NCDS 4P65-315

1750 n [min⁻¹]

ErP Ready



Operating data
Рабочие характеристики
Caratteristiche di funzionamento

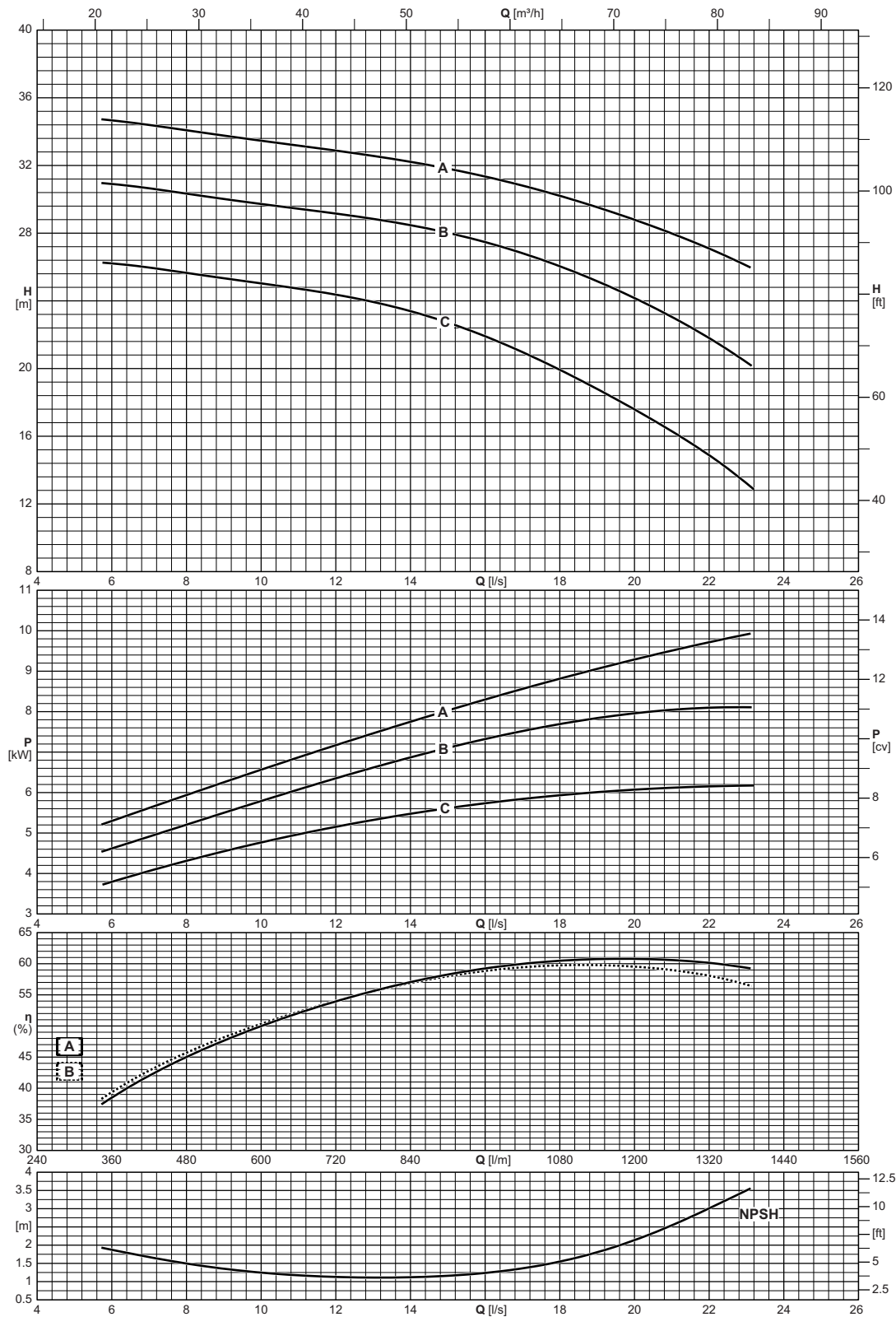

Type Тип Tipo	Inlet maximum pressure Макс. давление на всасывании Pressione massima in aspirazione
NCDS4P65-315	[bar] 10

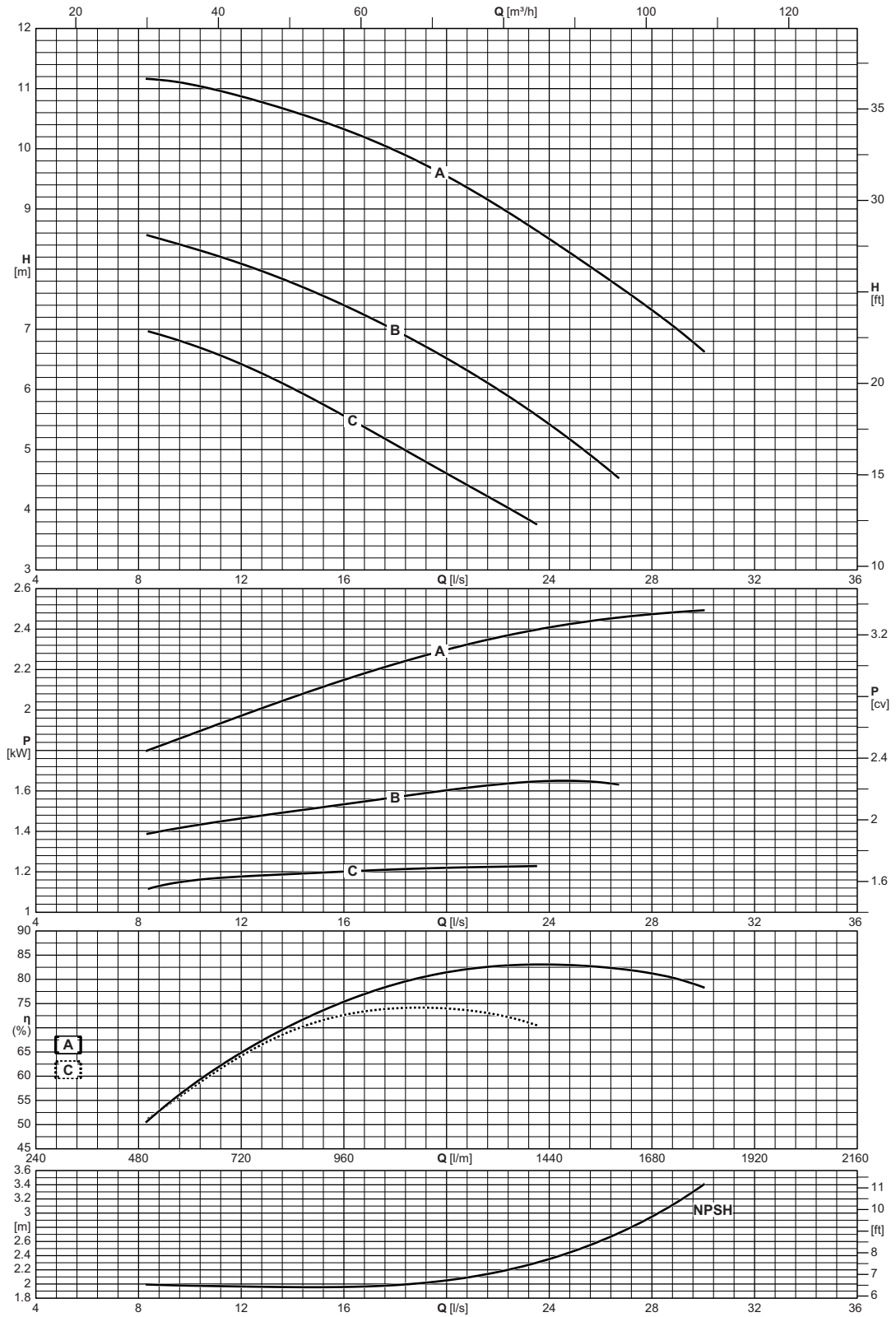

Type Тип Tipo	Inlet maximum pressure Макс. давление на всасывании Pressione massima in aspirazione
	[bar]
NCDS4P80-160	16

NCDS 4P80-200

1750 n [min⁻¹]

ErP Ready



Operating data
Рабочие характеристики
Caratteristiche di funzionamento

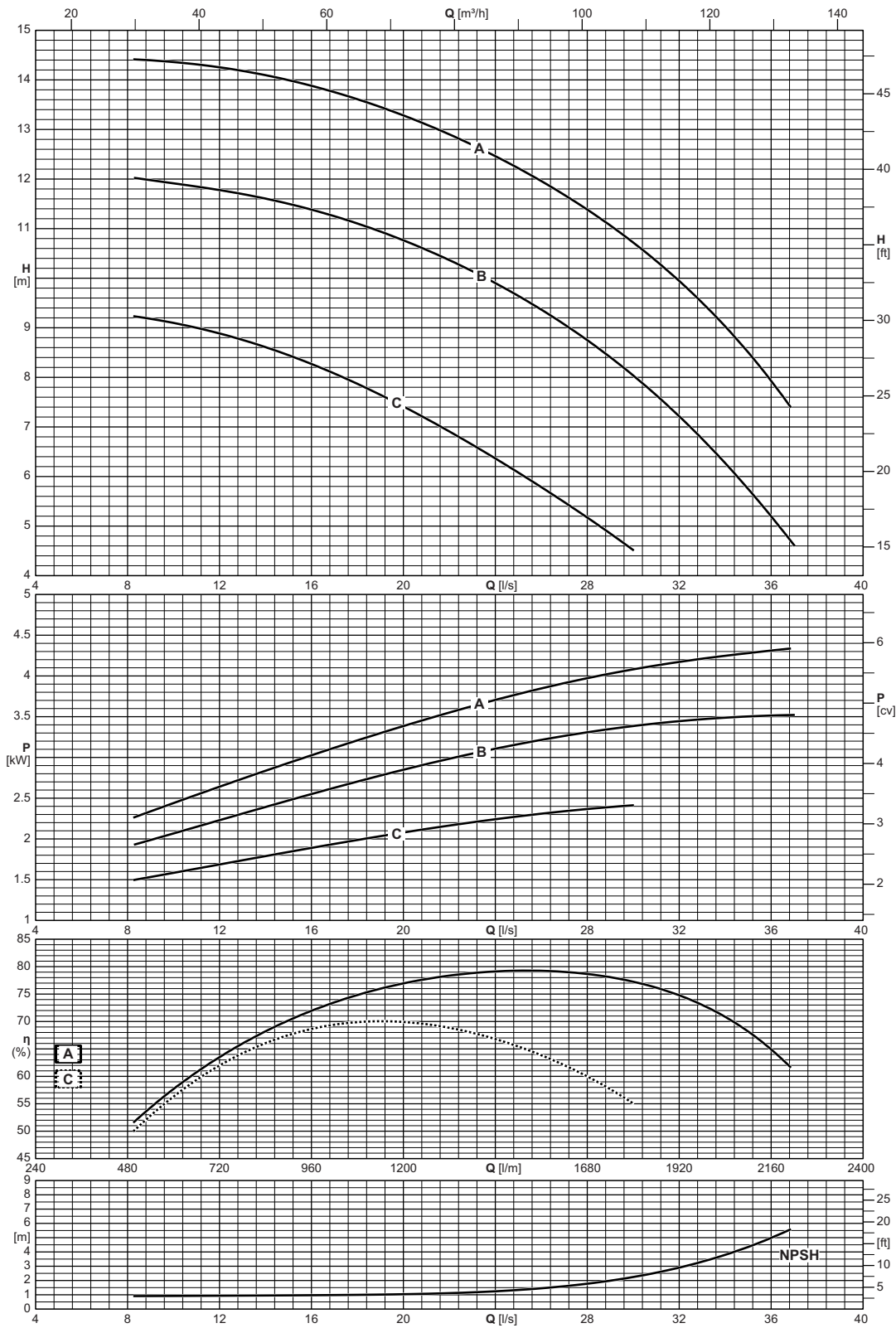

Type Тип Tipo	Inlet maximum pressure Макс. давление на всасывании Pressione massima in aspirazione
NCDS4P80-200	[bar] 10

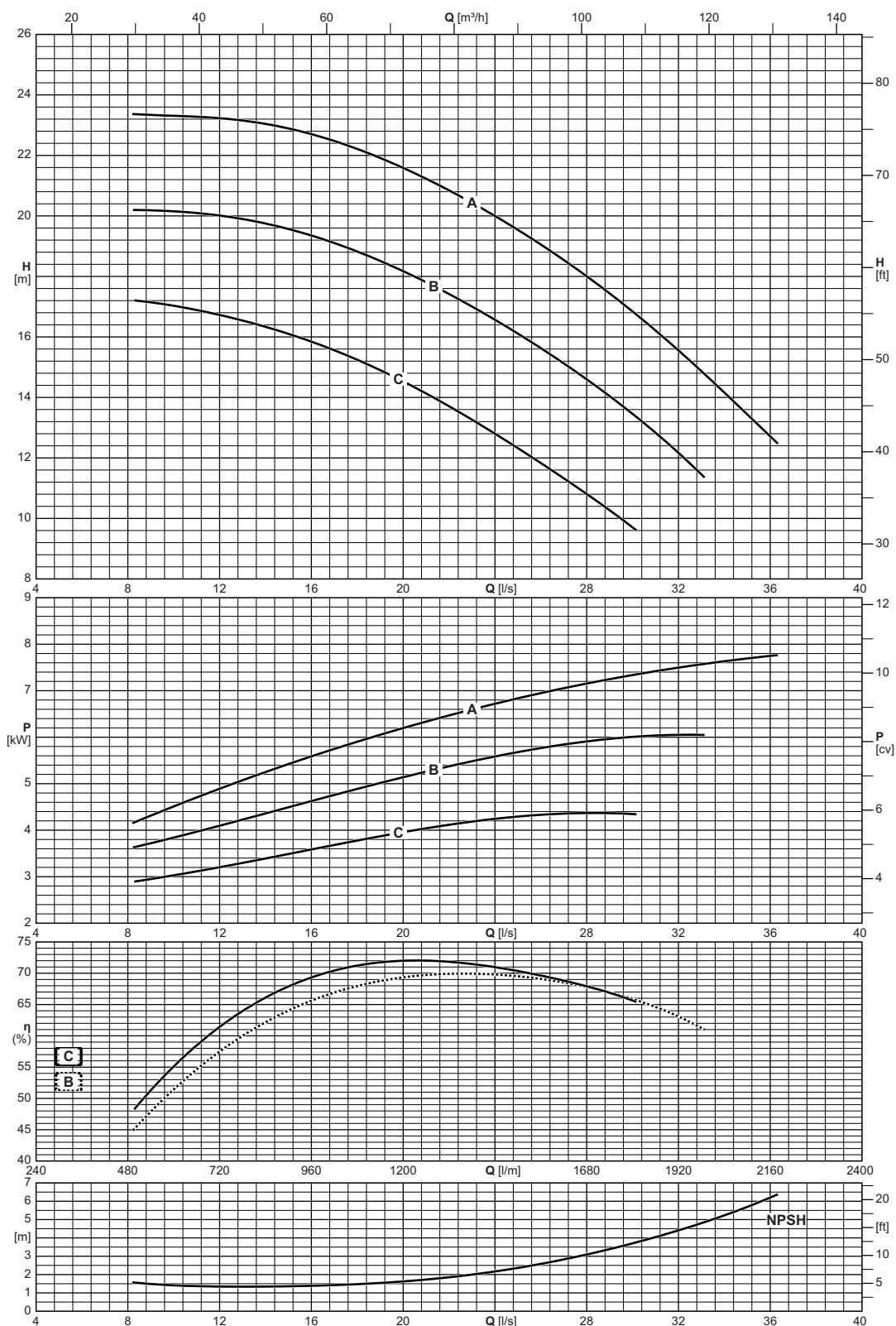

Type Тип Tipo	Inlet maximum pressure Макс. давление на всасывании Pressione massima in aspirazione
NCDS4P80-250	[bar] 16

NCDS 4P80-315

1750 n [min⁻¹]

ErP Ready



Operating data
Рабочие характеристики
Caratteristiche di funzionamento

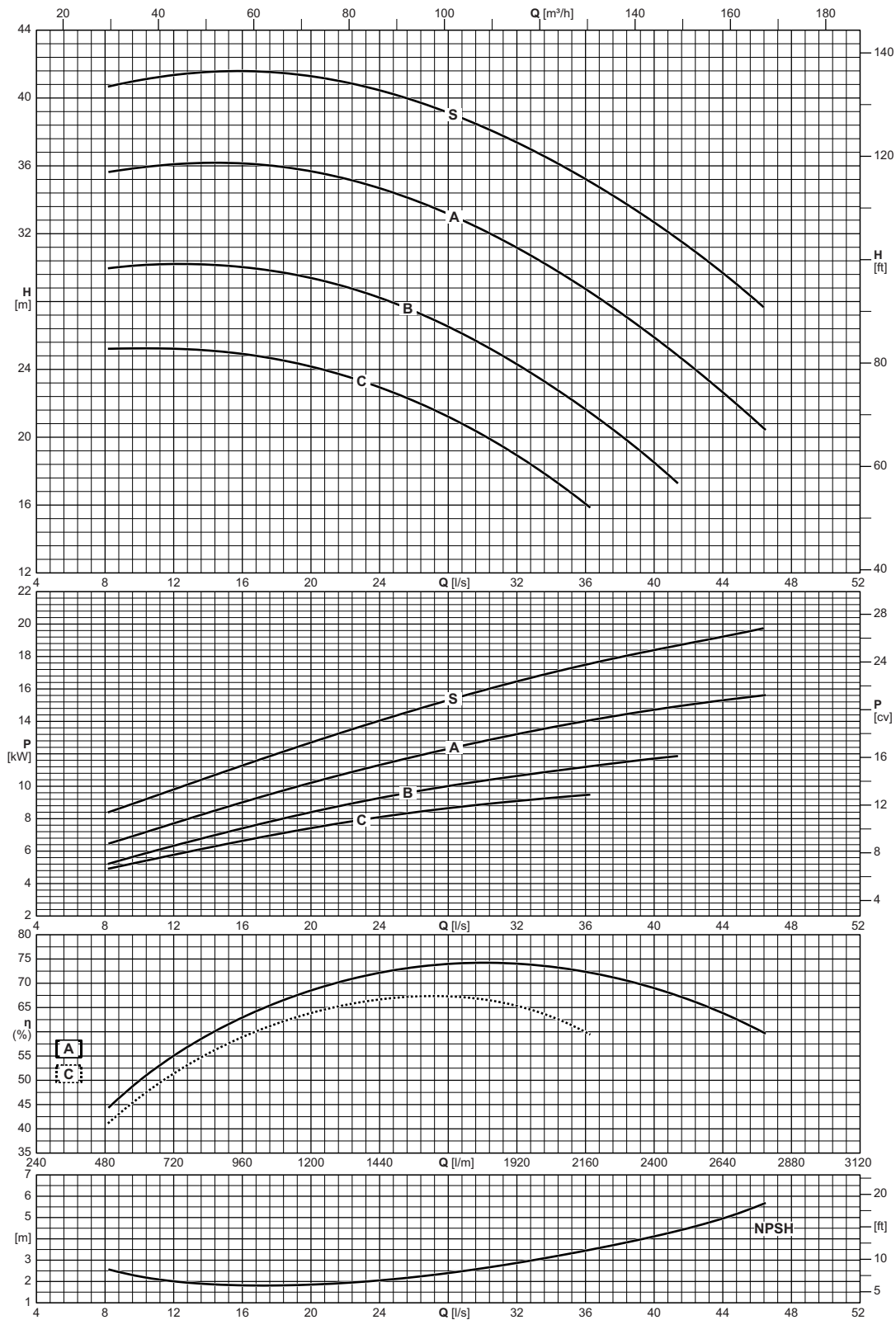

Type Тип Tipo	Inlet maximum pressure Макс. давление на всасывании Pressione massima in aspirazione
NCDS4P80-315	[bar] 16

Operating data
Рабочие характеристики
Caratteristiche di funzionamento

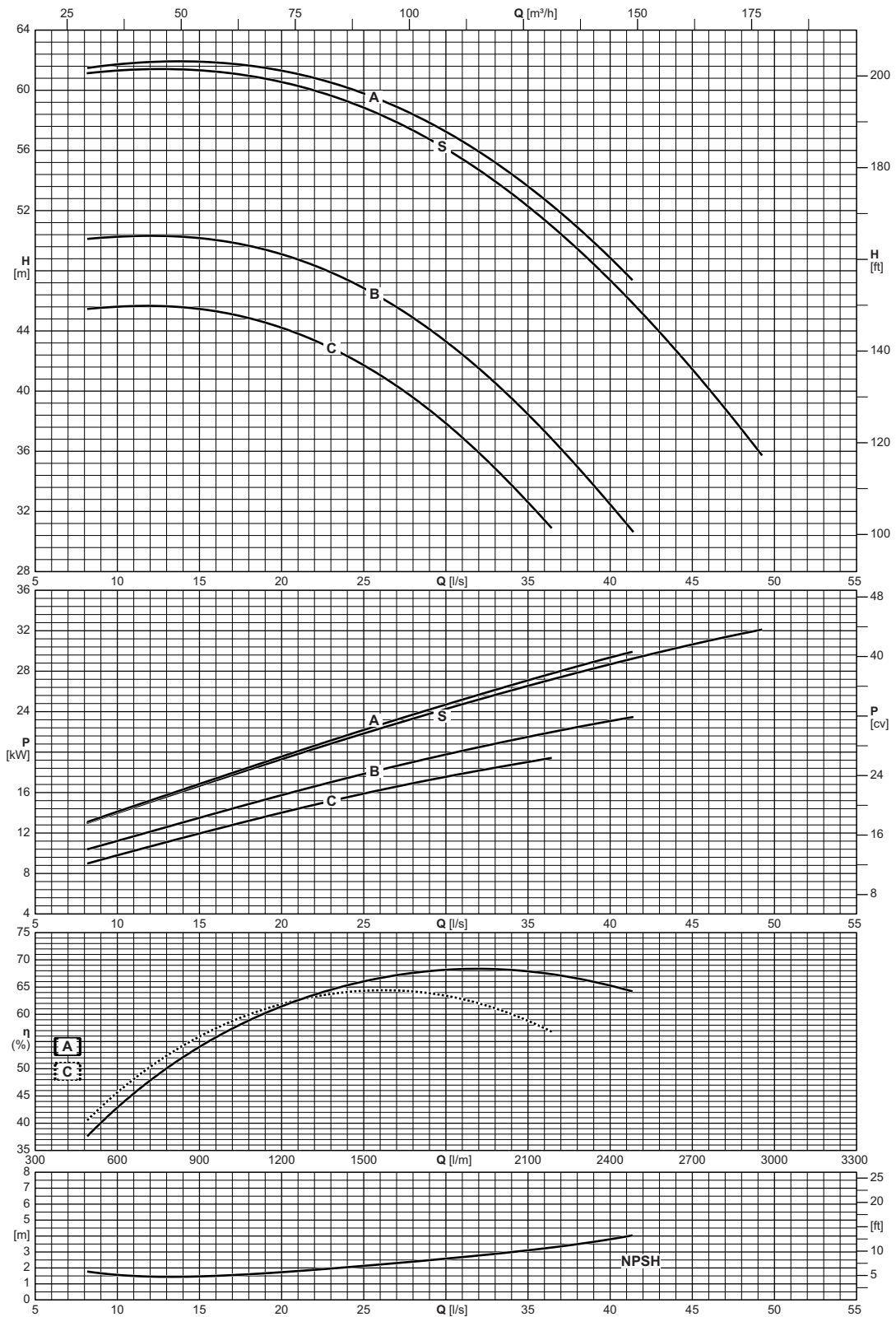

Type Тип Tipo	Inlet maximum pressure Макс. давление на всасывании Pressione massima in aspirazione [bar]
NCDS4P80-400	16

NCDS 4P100-200

1750 n [min⁻¹]

ErP Ready



Operating data
Рабочие характеристики
Caratteristiche di funzionamento

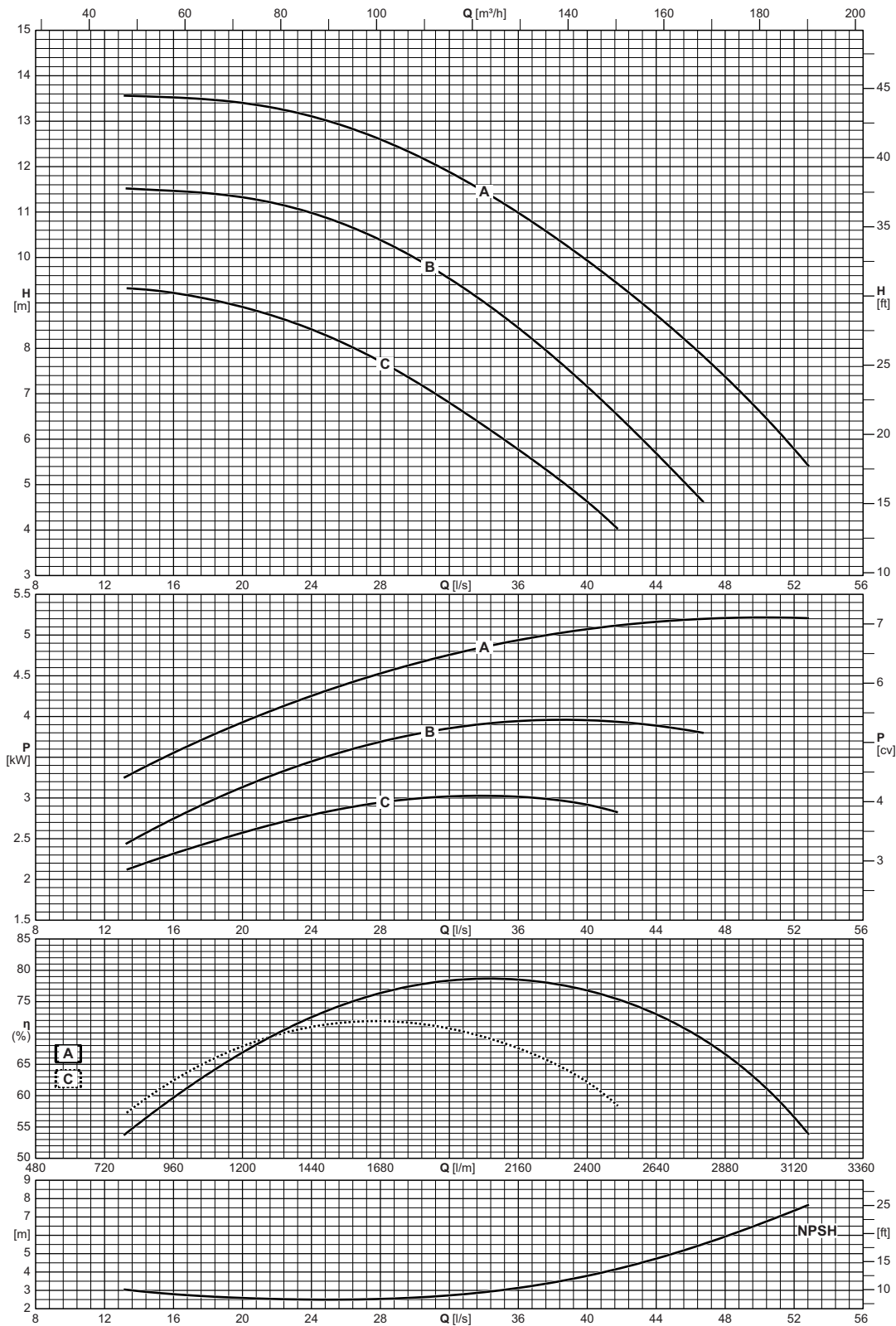

Type Тип Tipo	Inlet maximum pressure Макс. давление на всасывании Pressione massima in aspirazione
	[bar]
NCDS4P100-200	16

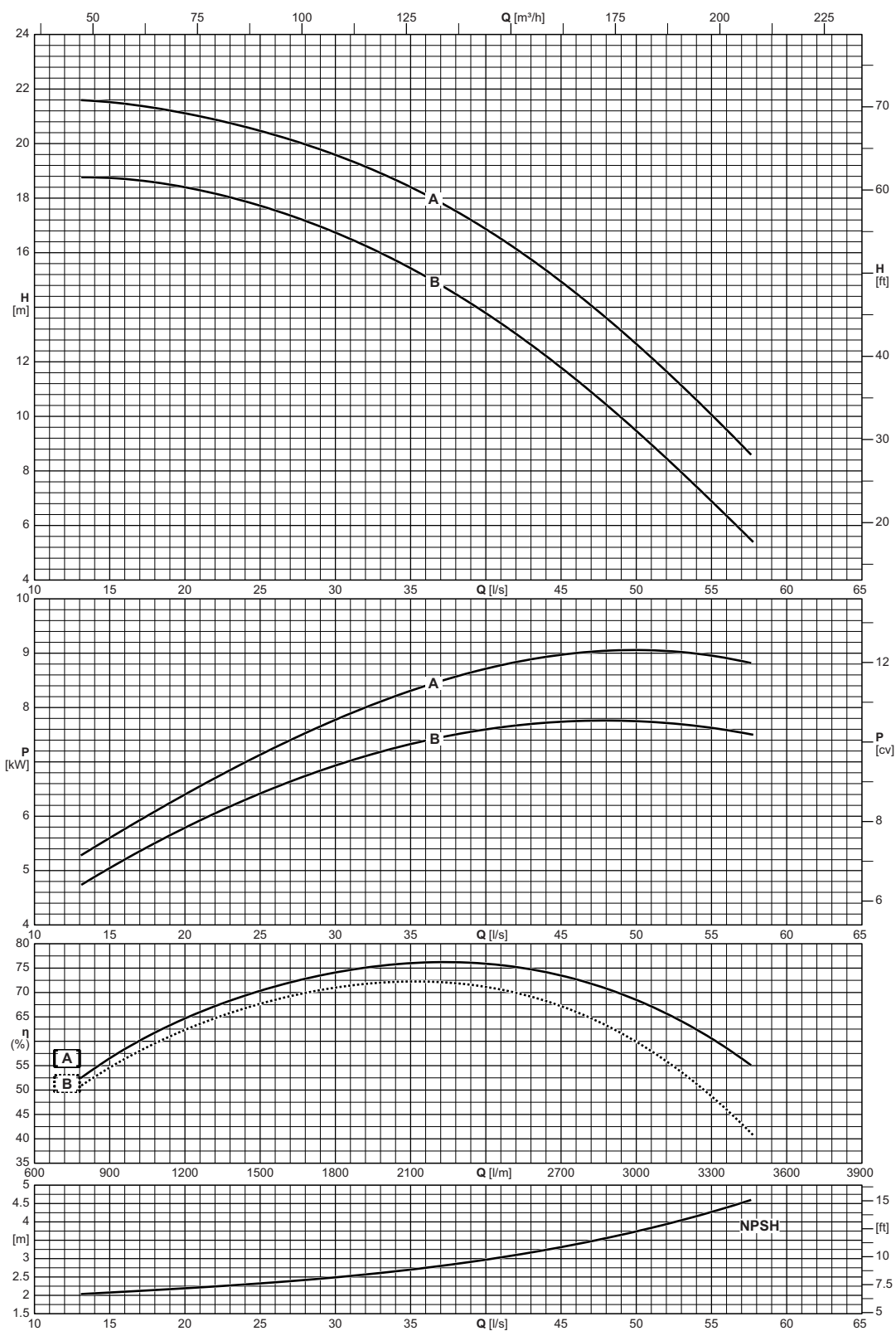

Type Typ Tipo	Inlet maximum pressure Макс. давление на всасывании Pressione massima in aspirazione
NCDS4P100-250	[bar] 10

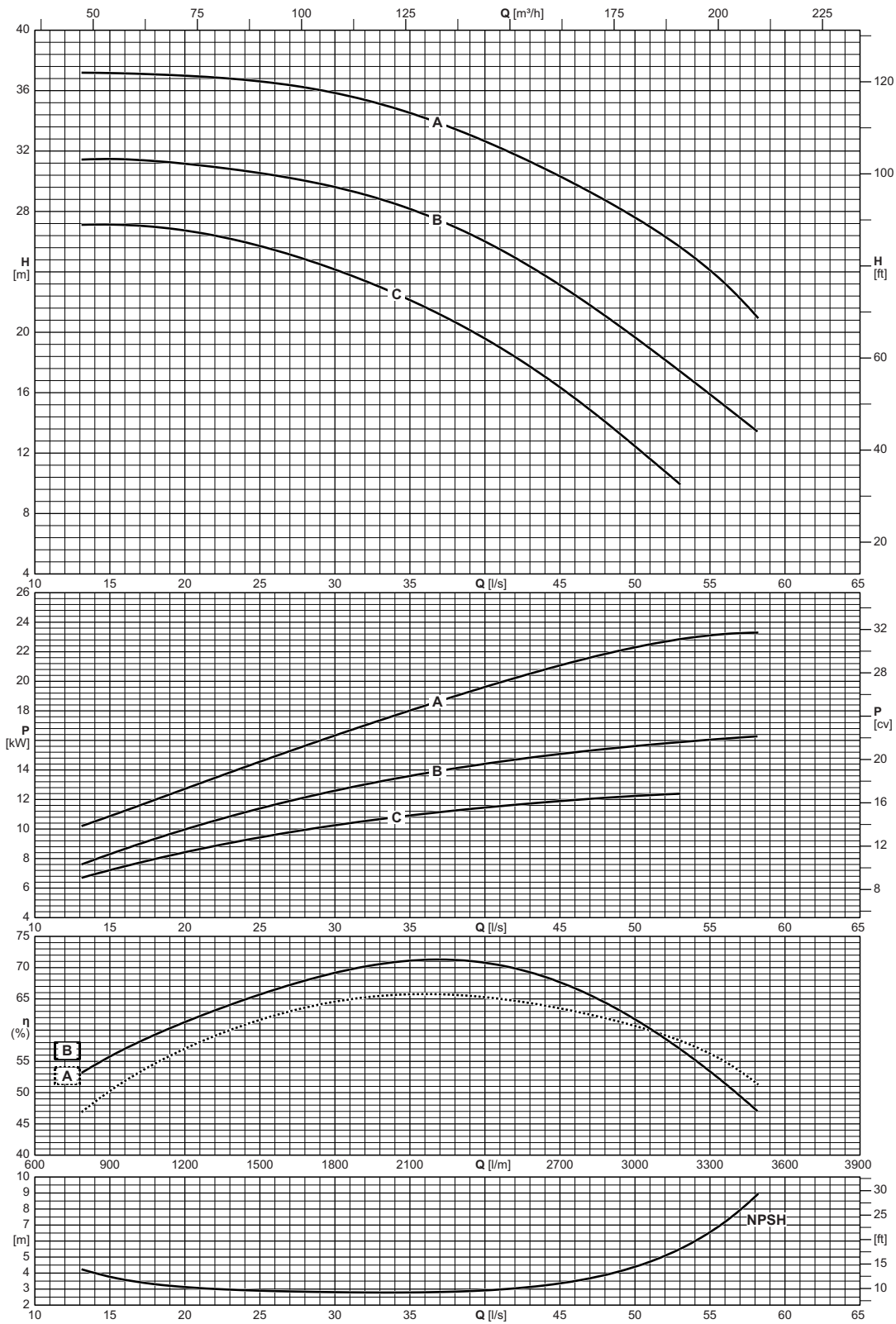

Type Тип Tipo	Inlet maximum pressure Макс. давление на всасывании Pressione massima in aspirazione
	[bar]
NCDS4P100-315	10

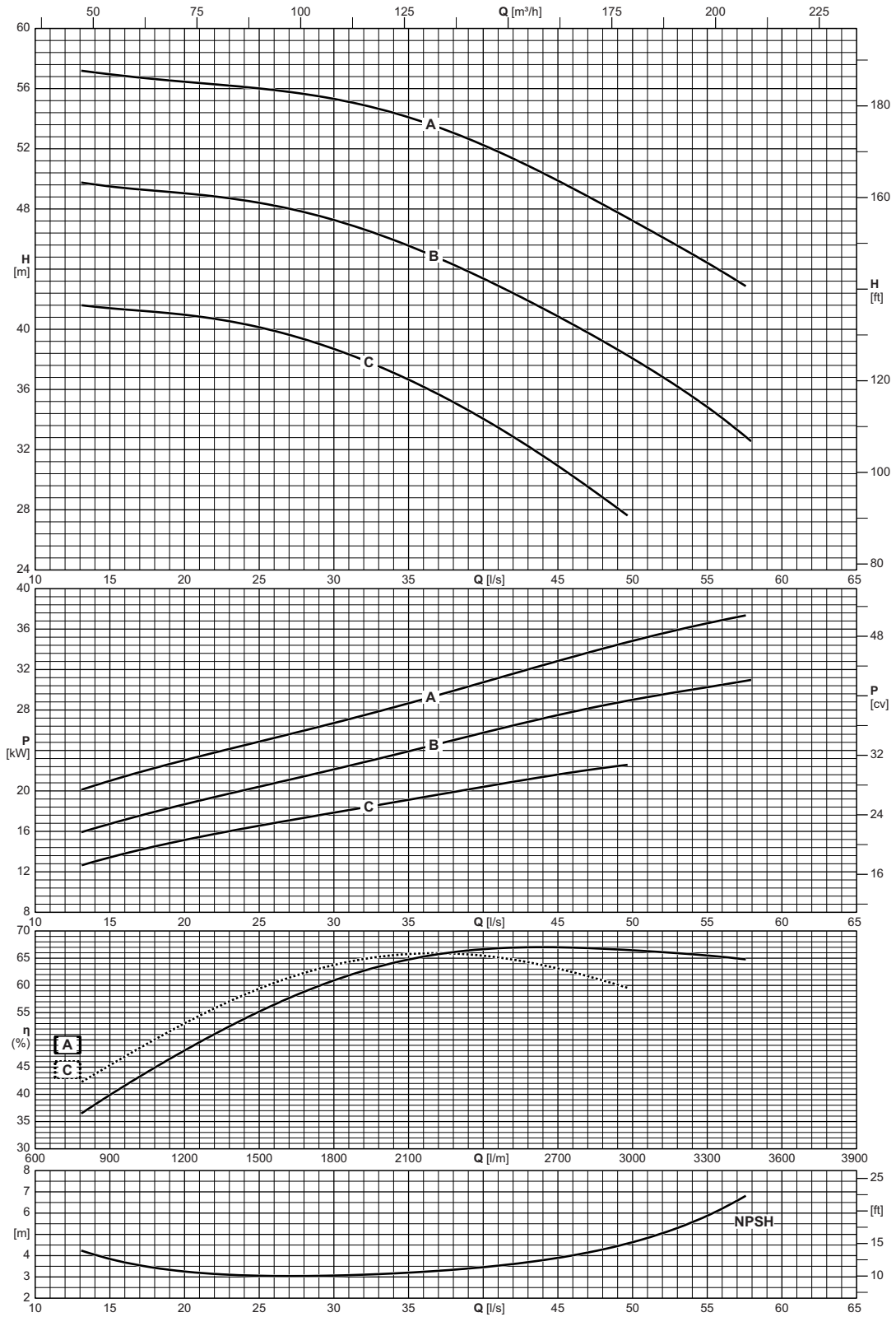

Type <i>Tun</i> Tipo	Inlet maximum pressure <i>Макс. давление на всасывании</i> Pressione massima in aspirazione
NCDS4P100-400	[bar] 10

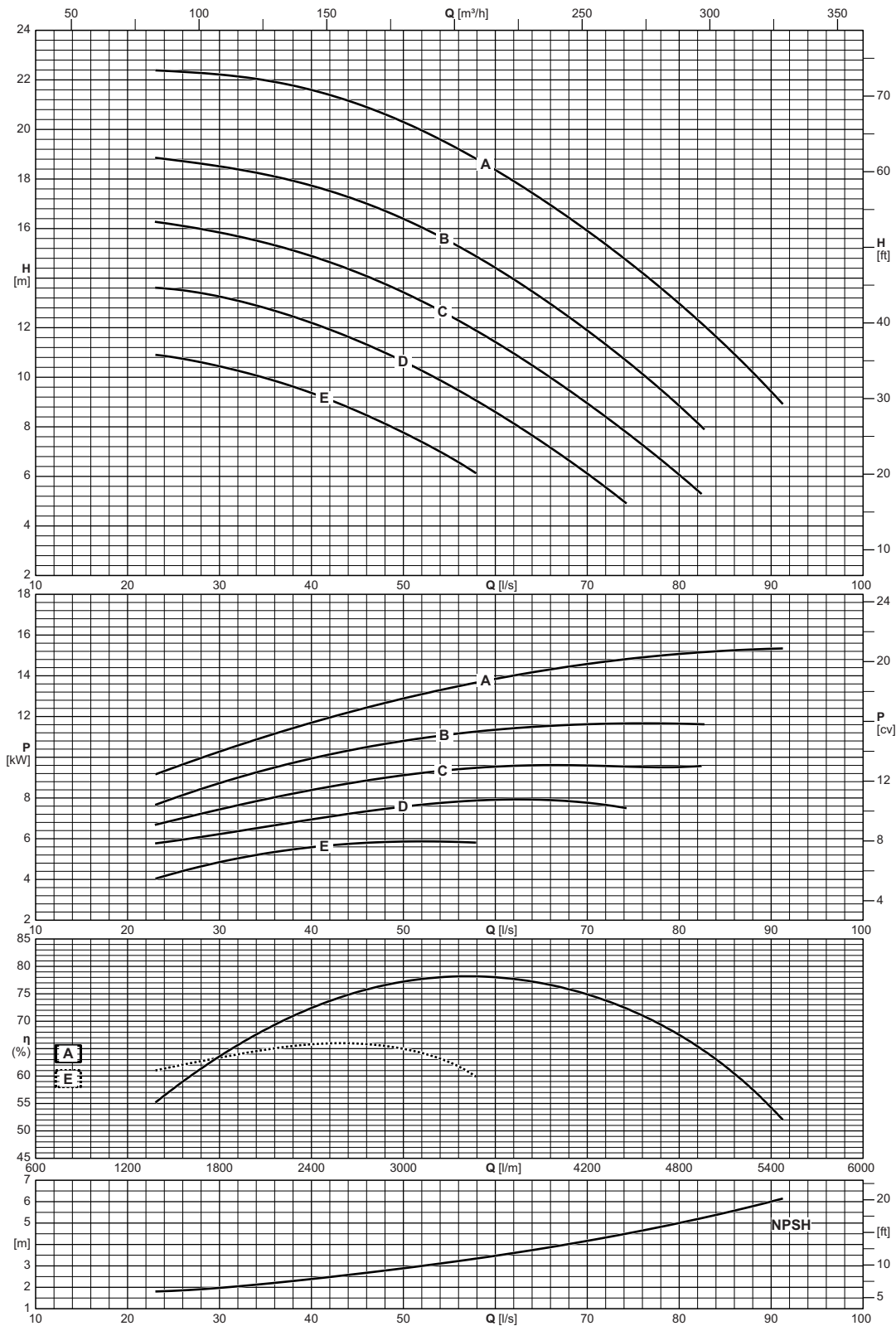

Type Тип Tipo	Inlet maximum pressure Макс. давление на всасывании Pressione massima in aspirazione
NCDS4P125-250	[bar] 10

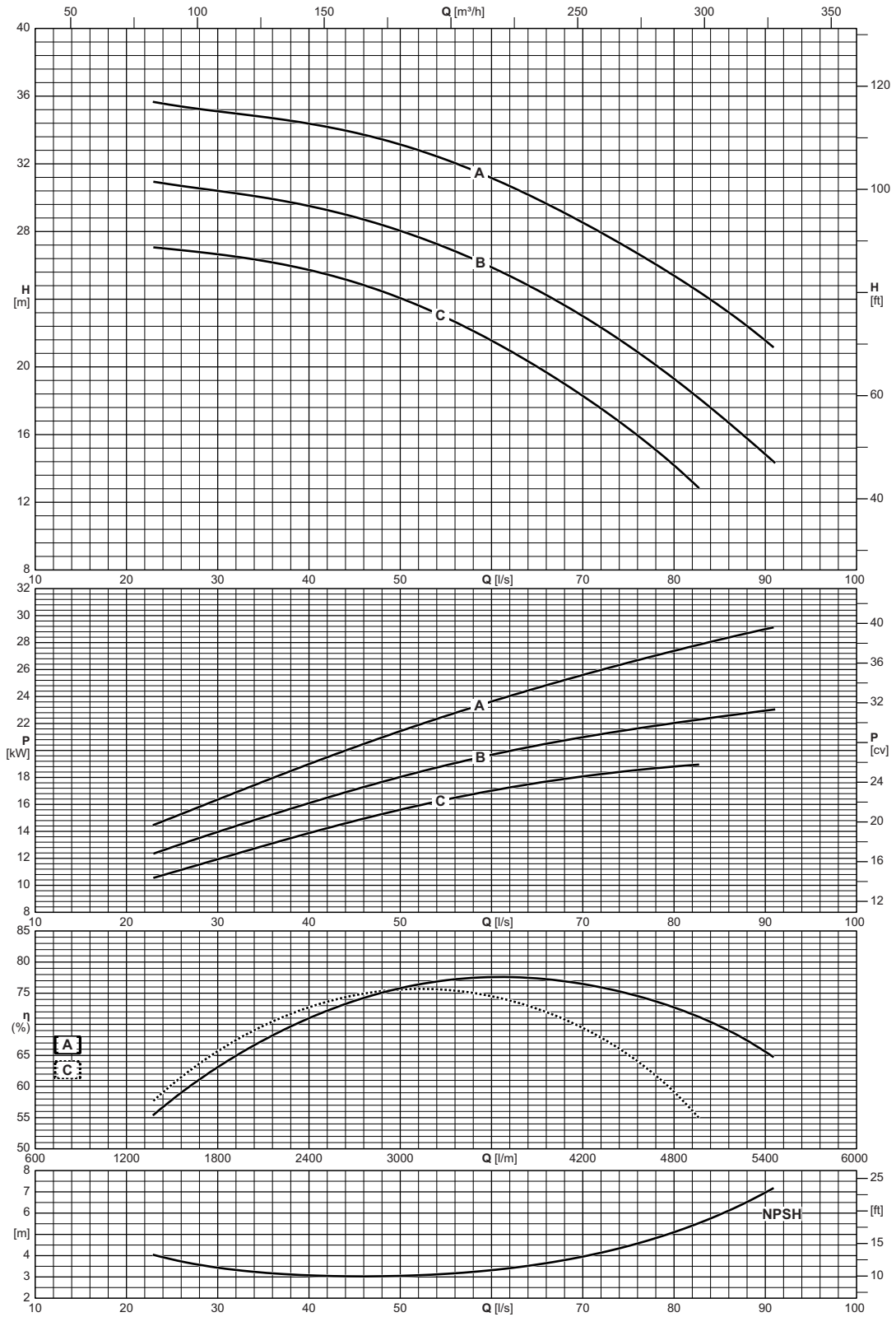

Type Тип Tipo	Inlet maximum pressure Макс. давление на всасывании Pressione massima in aspirazione
NCDS4P125-315	[bar] 16

NCDS 4P125-400

1750 n [min⁻¹]

ErP Ready



Operating data
Рабочие характеристики
Caratteristiche di funzionamento

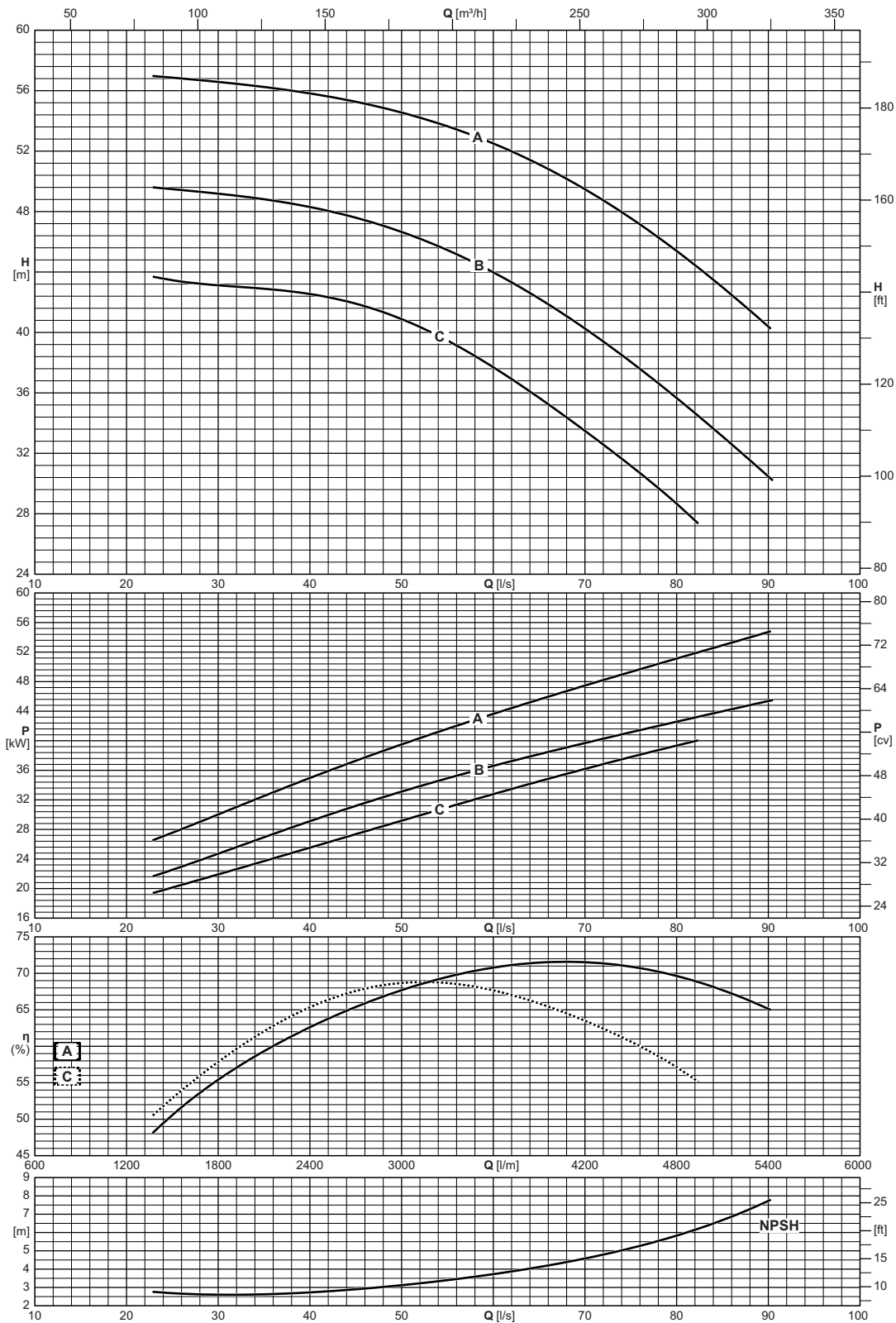

Type Тип Tipo	Inlet maximum pressure Макс. давление на всасывании Pressione massima in aspirazione
	[bar]
NCDS4P125-400	10

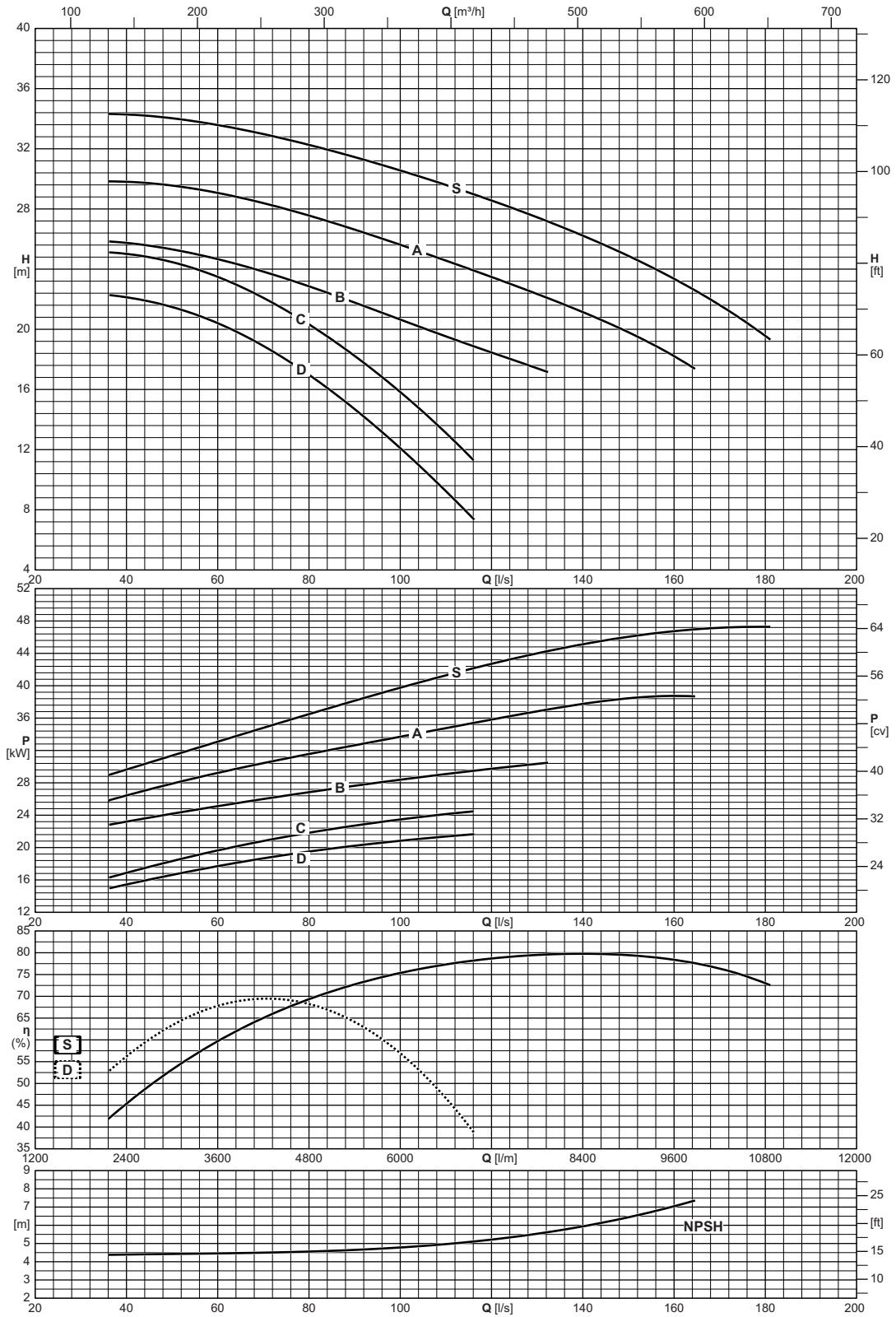

Type Тип Tipo	Inlet maximum pressure Макс. давление на всасывании Pressione massima in aspirazione
NCDS4P150-315	[bar] 10

NCDS 4P150-400

1750 n [min⁻¹]

ErP Ready



Operating data
Рабочие характеристики
Caratteristiche di funzionamento

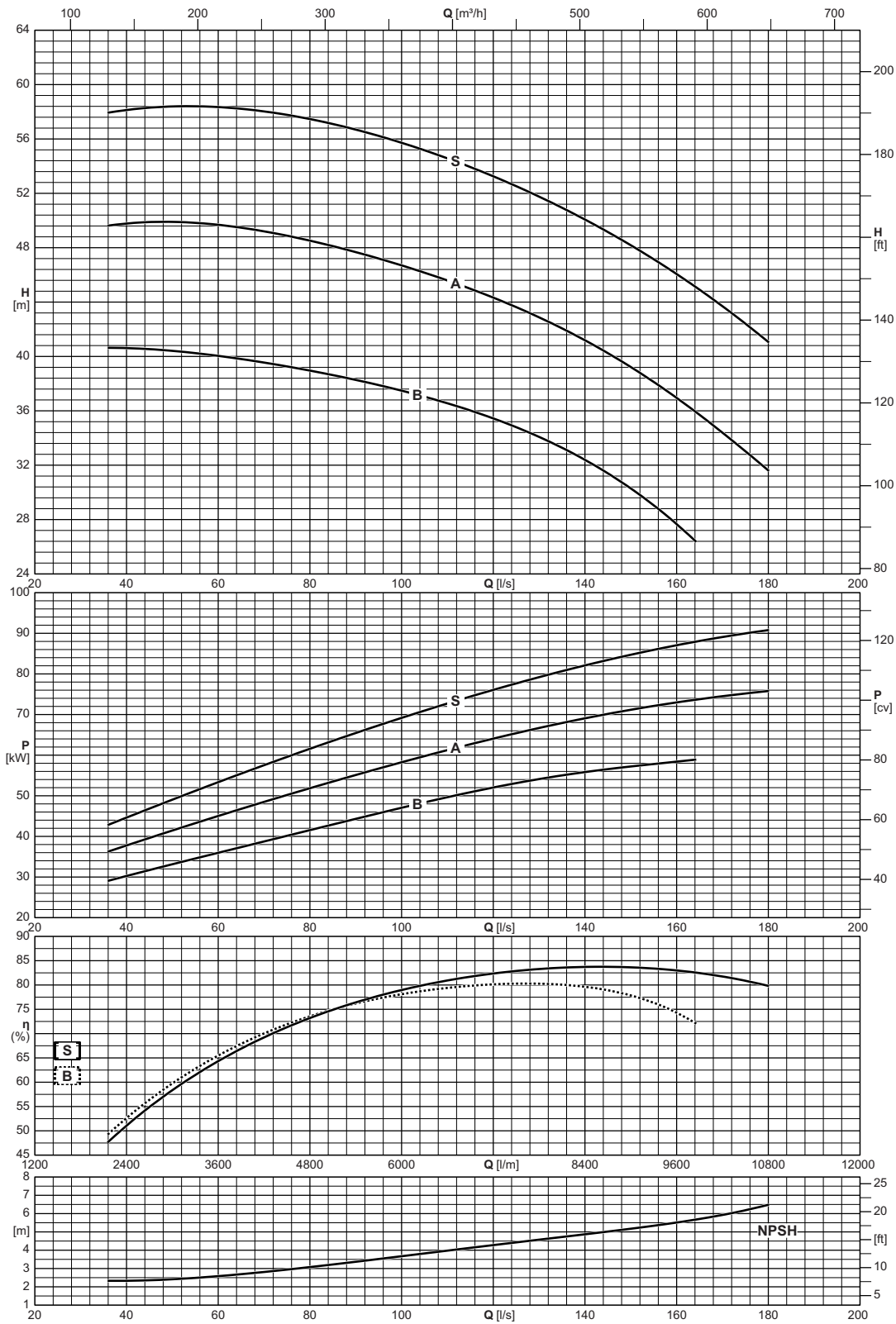

Type Тип Tipo	Inlet maximum pressure Макс. давление на всасывании Pressione massima in aspirazione
NCDS4P150-400	[bar] 10

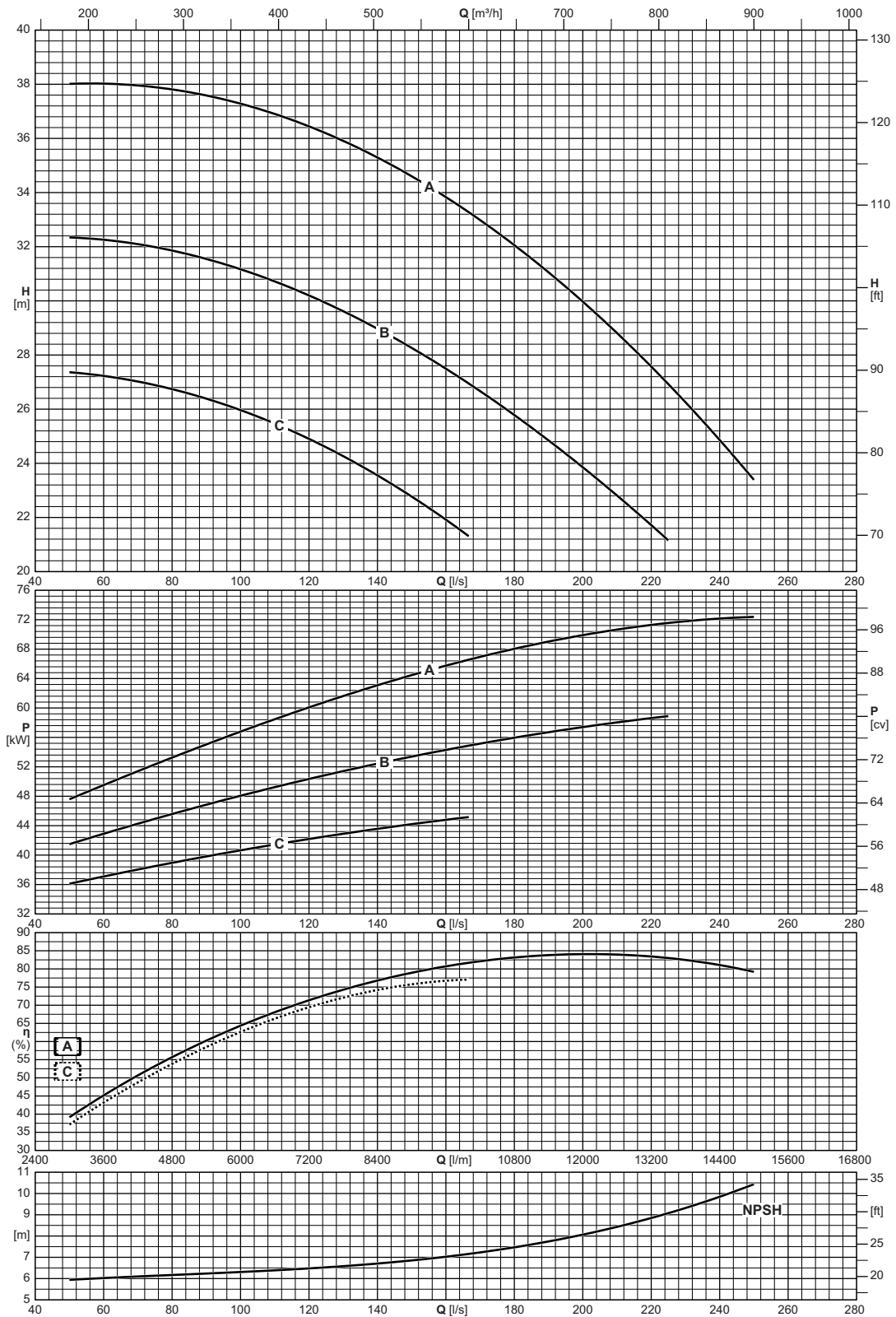

Type Тип Tipo	Inlet maximum pressure Макс. давление на всасывании Pressione massima in aspirazione
NCDS4P200-315	[bar] 16

NCDS 4P200-400

1750 n [min⁻¹]



Operating data
Рабочие характеристики
Caratteristiche di funzionamento

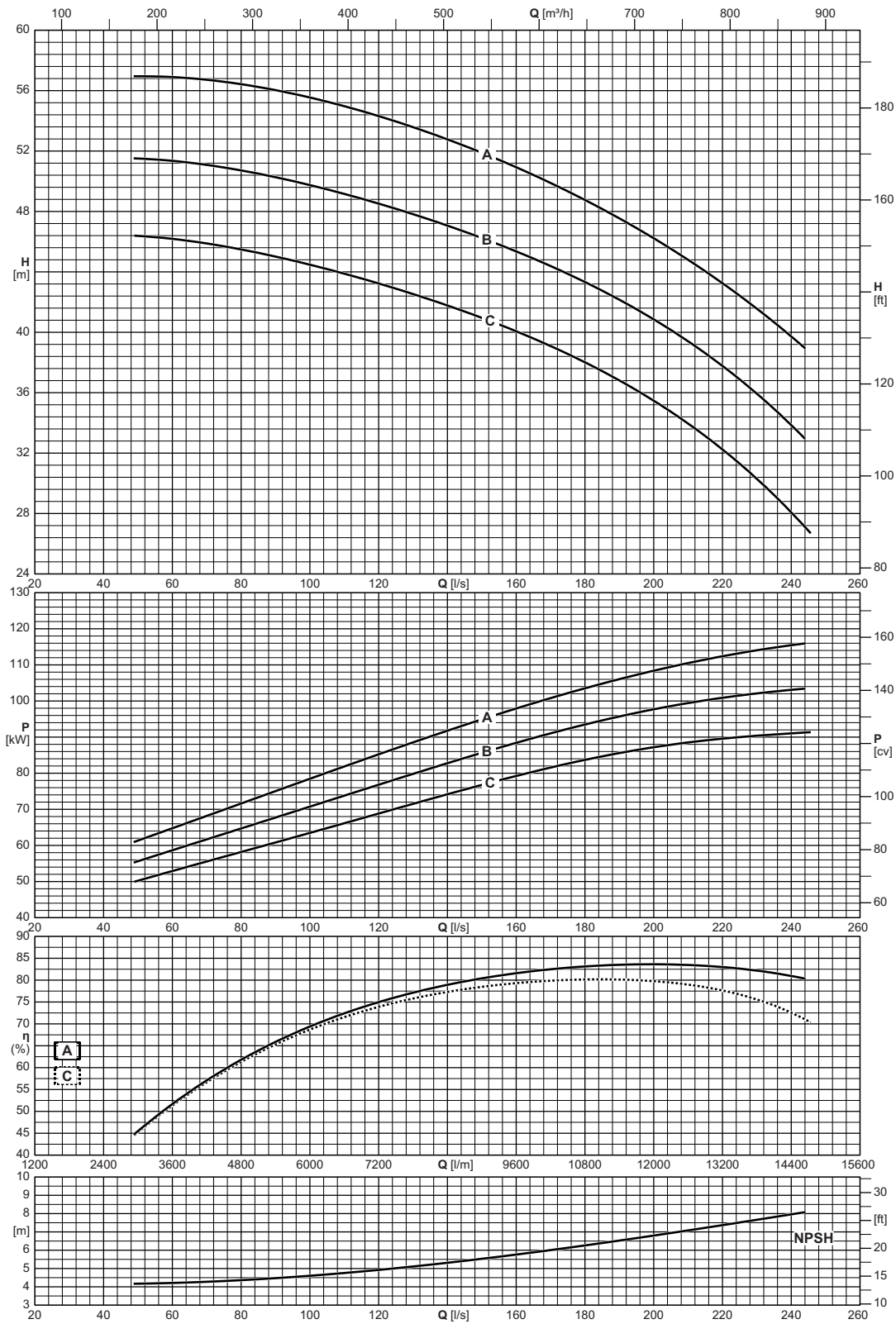

Type Тип Tipo	Inlet maximum pressure Макс. давление на всасывании Pressione massima in aspirazione
NCDS4P200-400	[bar] 16

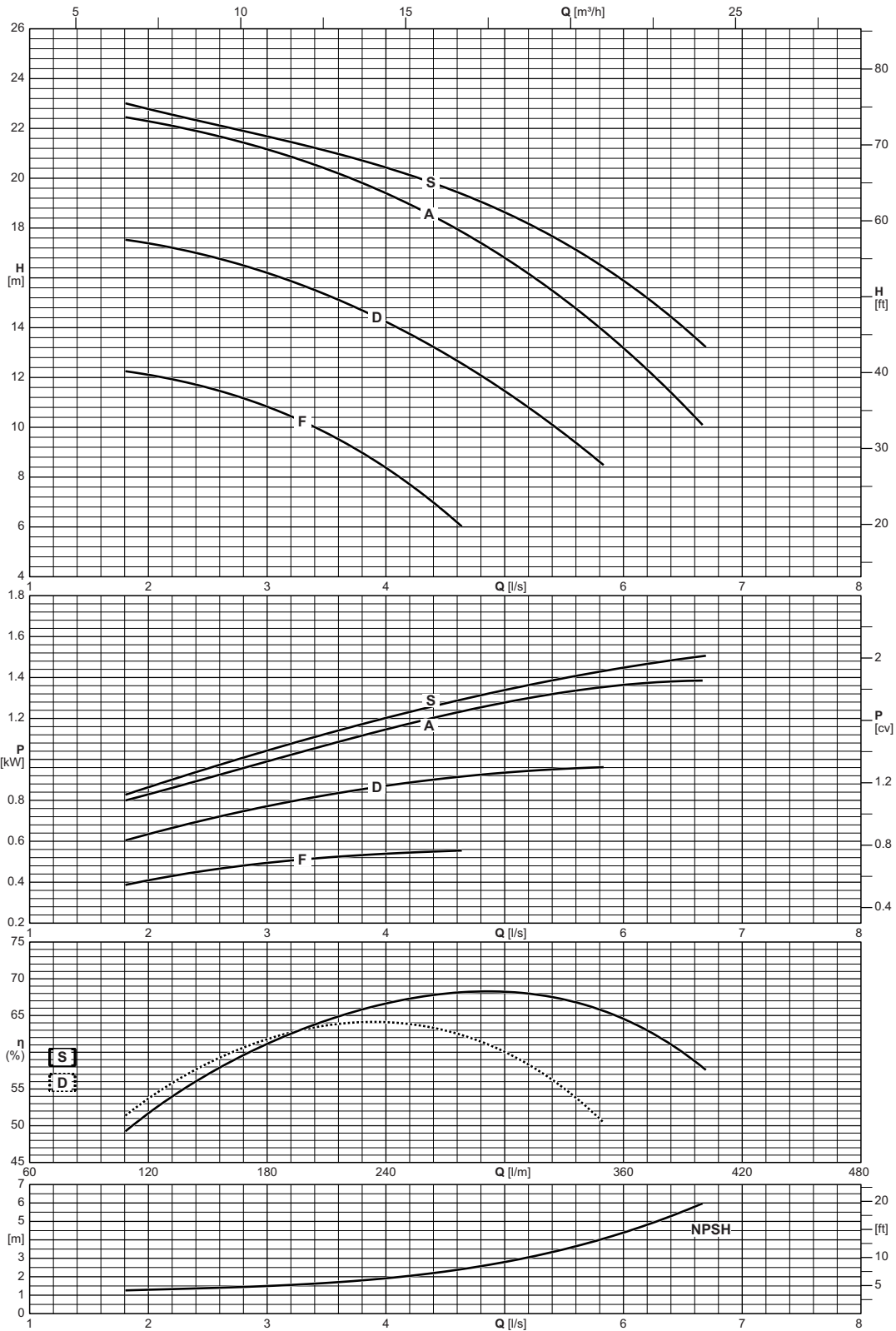

Type Тип Tipo	Inlet maximum pressure Макс. давление на всасывании Pressione massima in aspirazione [bar]
NCD2P32-125	10

NCD 2P32-160

2900 n [min⁻¹]

ErP Ready



Operating data
Рабочие характеристики
Caratteristiche di funzionamento

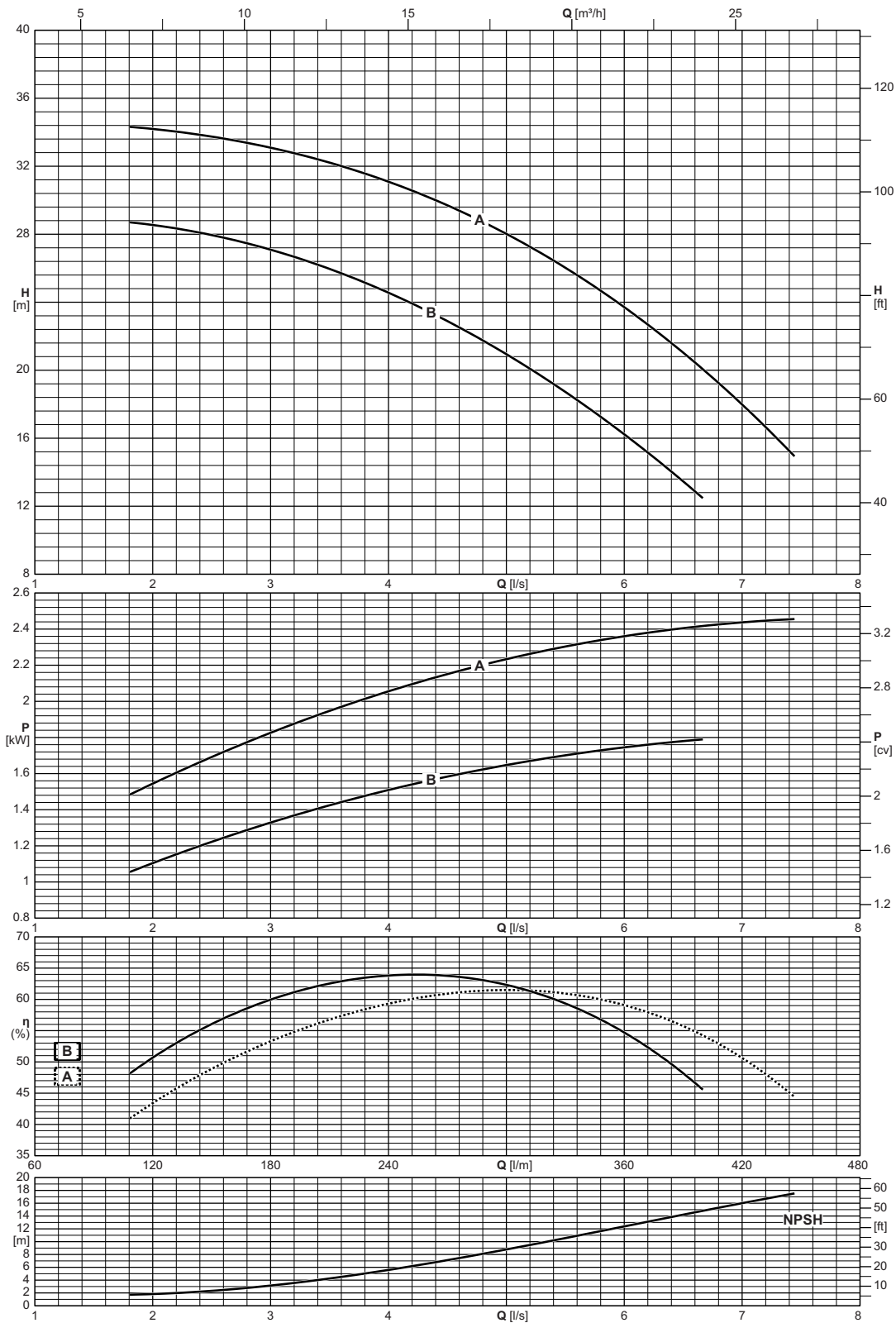

Type Тип Tipo	Inlet maximum pressure Макс. давление на всасывании Pressione massima in aspirazione
NCD2P32-160	[bar] 10

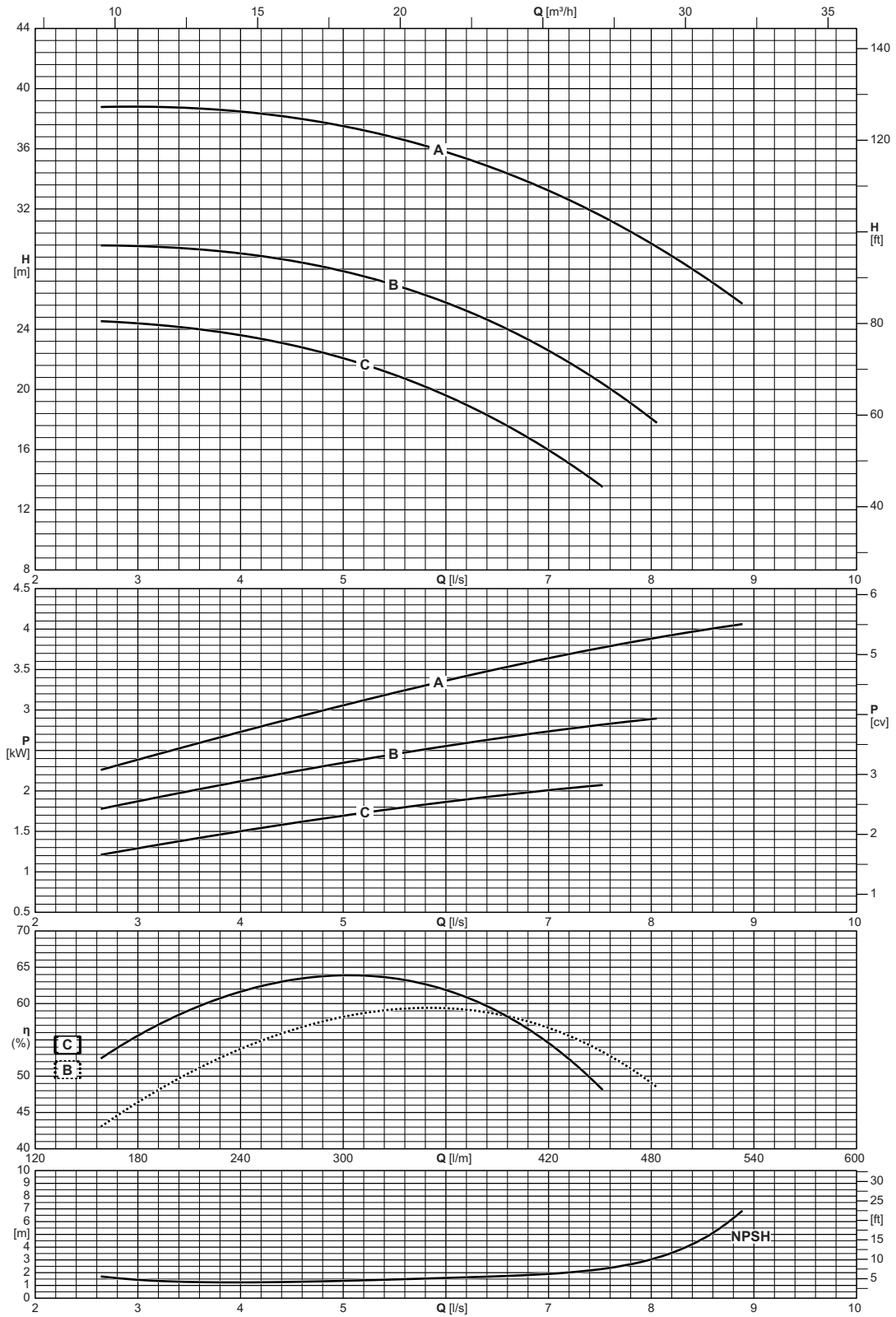

Type <i>Tun</i> Tipo	Inlet maximum pressure <i>Макс. давление на всасывании</i> Pressione massima in aspirazione
NCD2P32L-160	[bar] 16

NCD 2P32L-200

2900 n [min⁻¹]

ErP Ready



Operating data
Рабочие характеристики
Caratteristiche di funzionamento

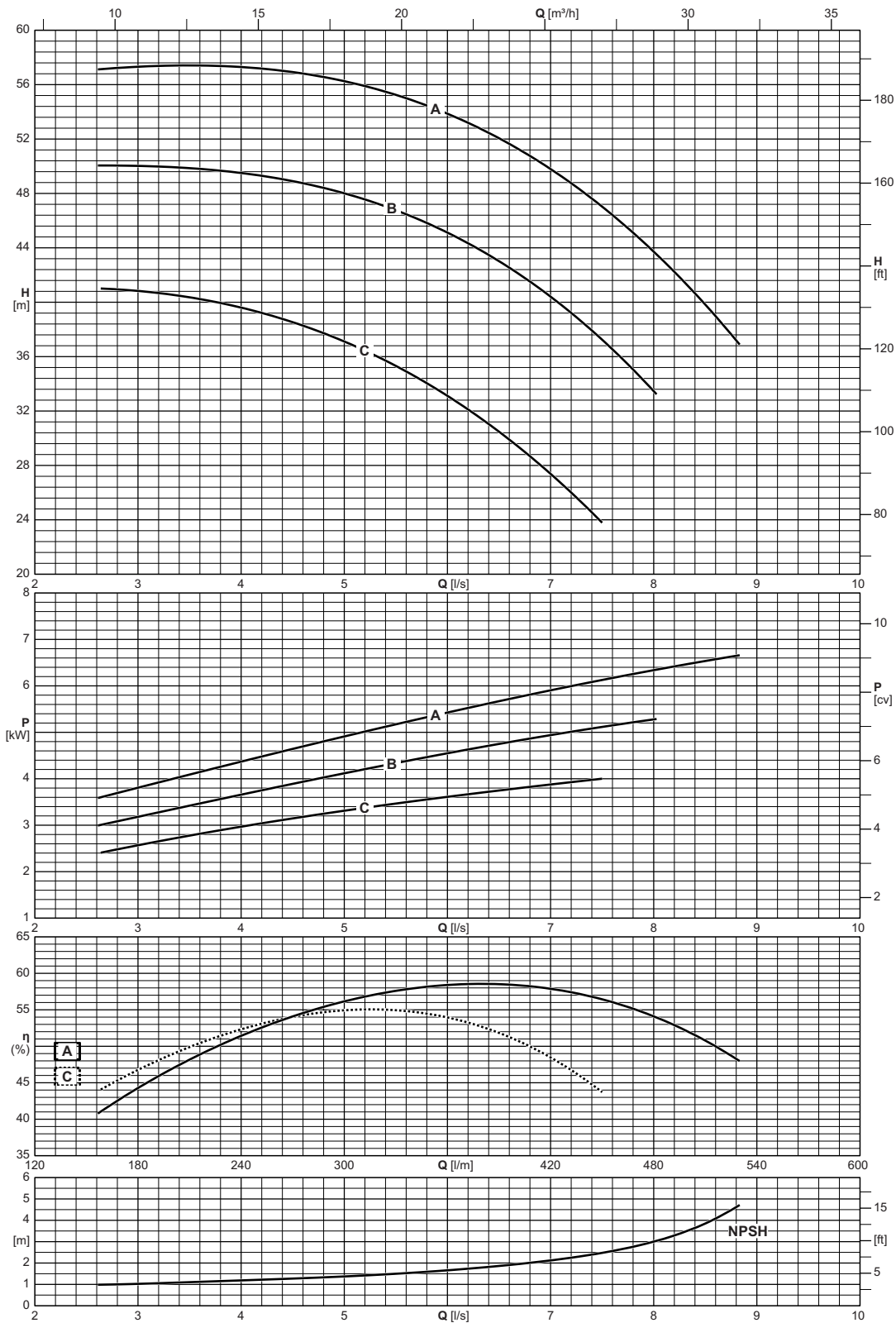

Type Тип Tipo	Inlet maximum pressure Макс. давление на всасывании Pressione massima in aspirazione
NCD2P32L-200	[bar] 16

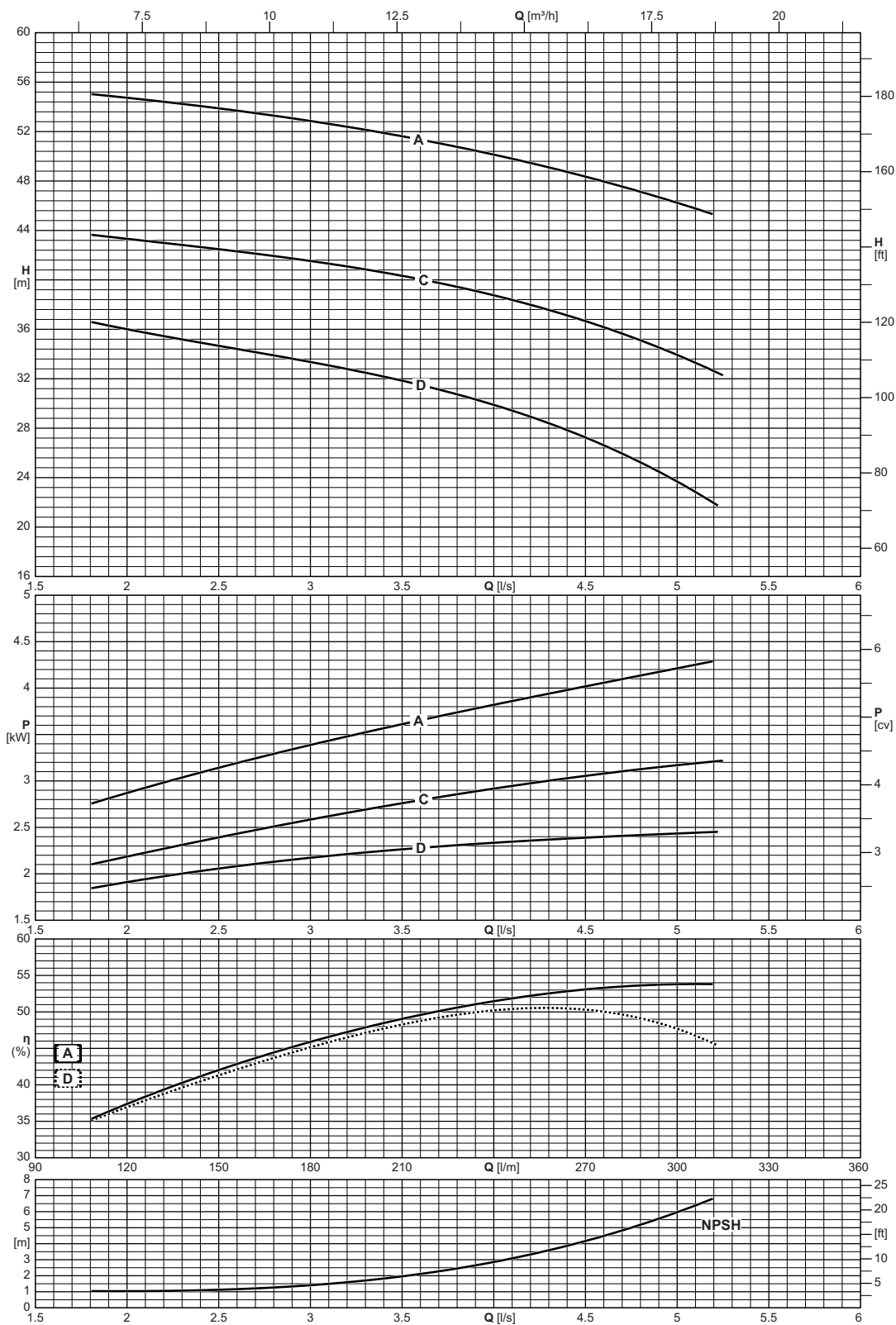

Type <i>Tun</i> Tipo	Inlet maximum pressure Макс. давление на всасывании Pressione massima in aspirazione
	[bar]
NCD2P32-200	10

NCD 2P40-125

2900 n [min⁻¹]

ErP Ready



Operating data
Рабочие характеристики
Caratteristiche di funzionamento

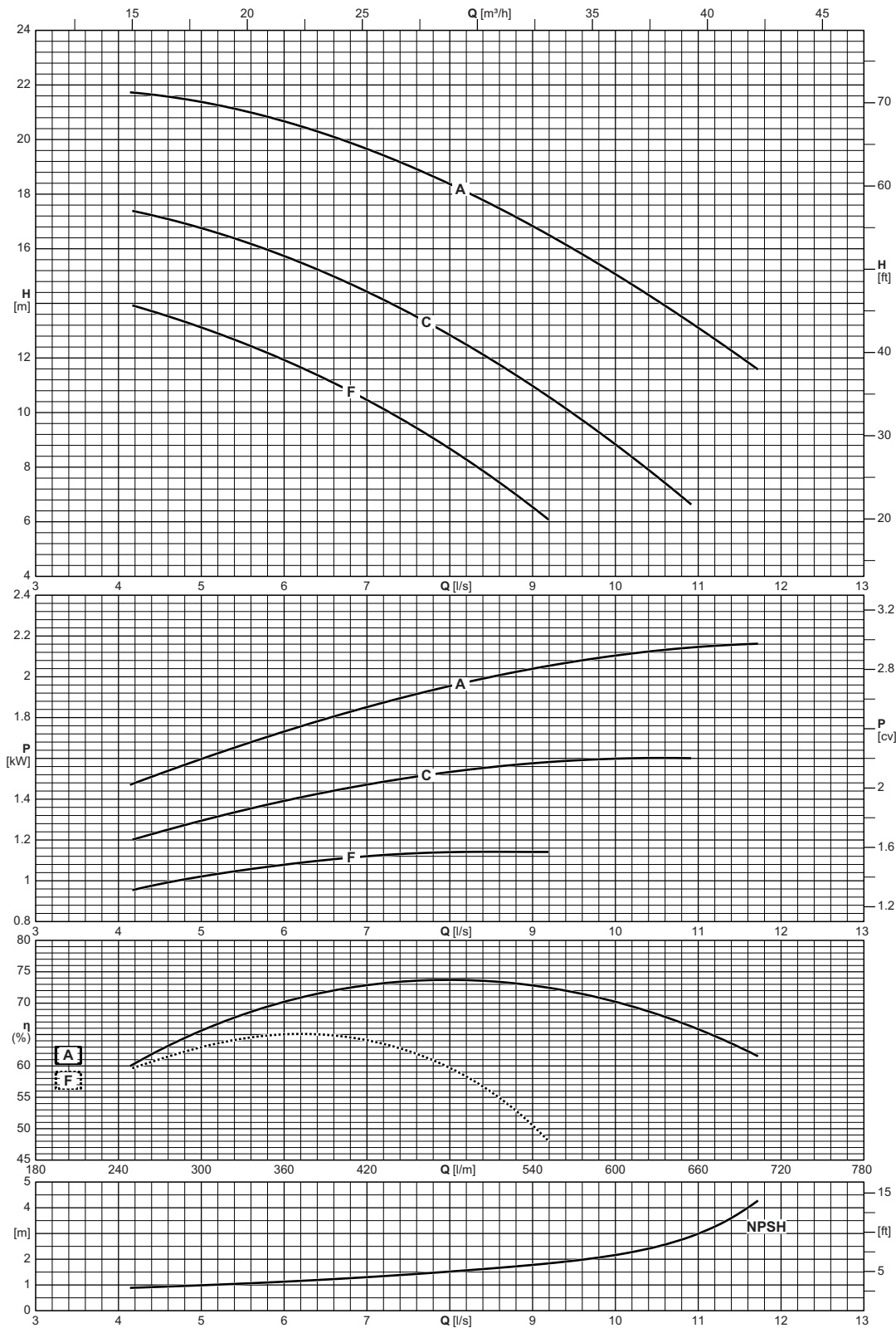

Type Тип Tipo	Inlet maximum pressure Макс. давление на всасывании Pressione massima in aspirazione
NCD2P40-125	[bar] 10

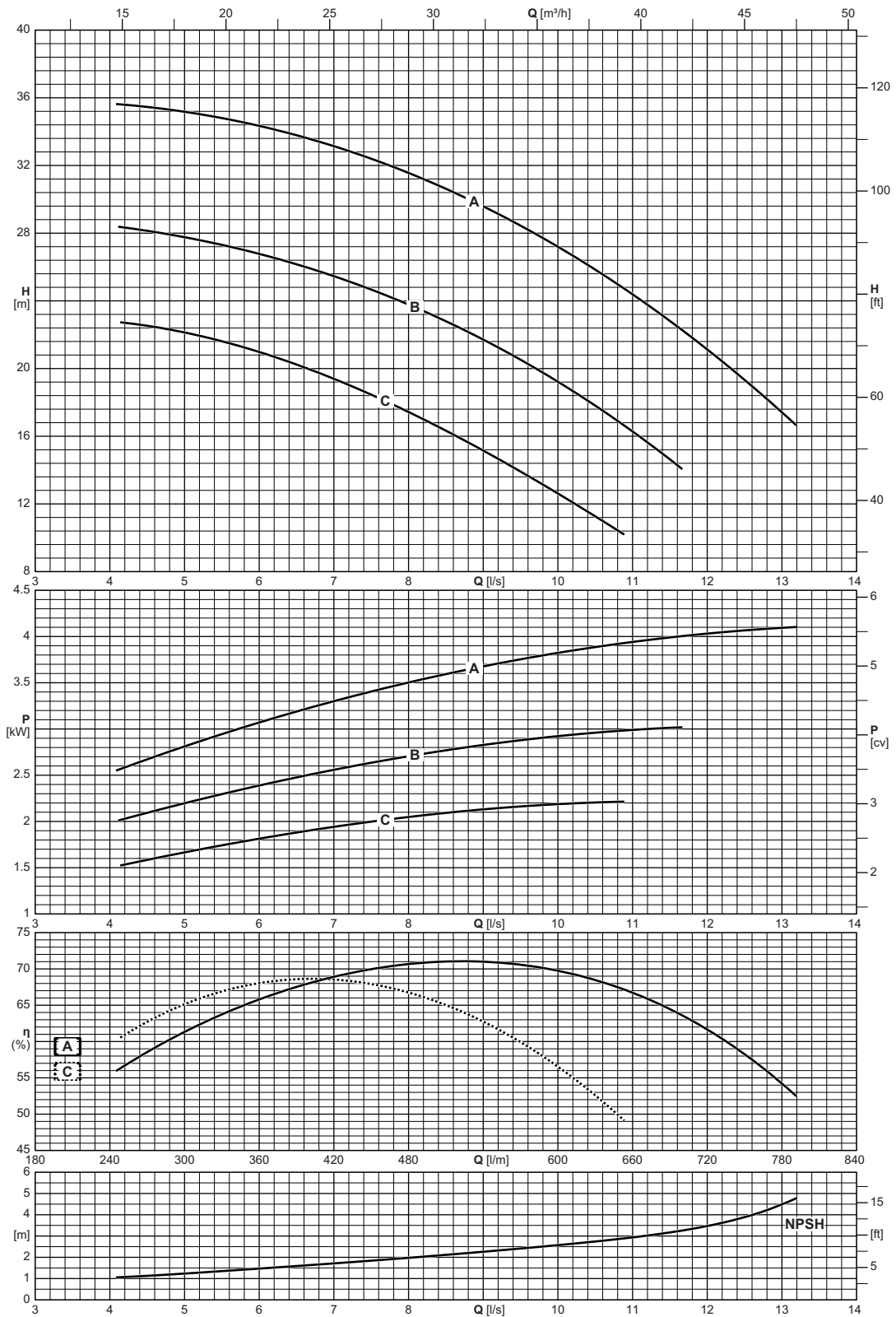

Type <i>Tun</i> Tipo	Inlet maximum pressure <i>Макс. давление на всасывании</i> Pressione massima in aspirazione
	[bar]
NCD2P40-160	16

NCD 2P40-200

2900 n [min⁻¹]

ErP Ready



Operating data
Рабочие характеристики
Caratteristiche di funzionamento

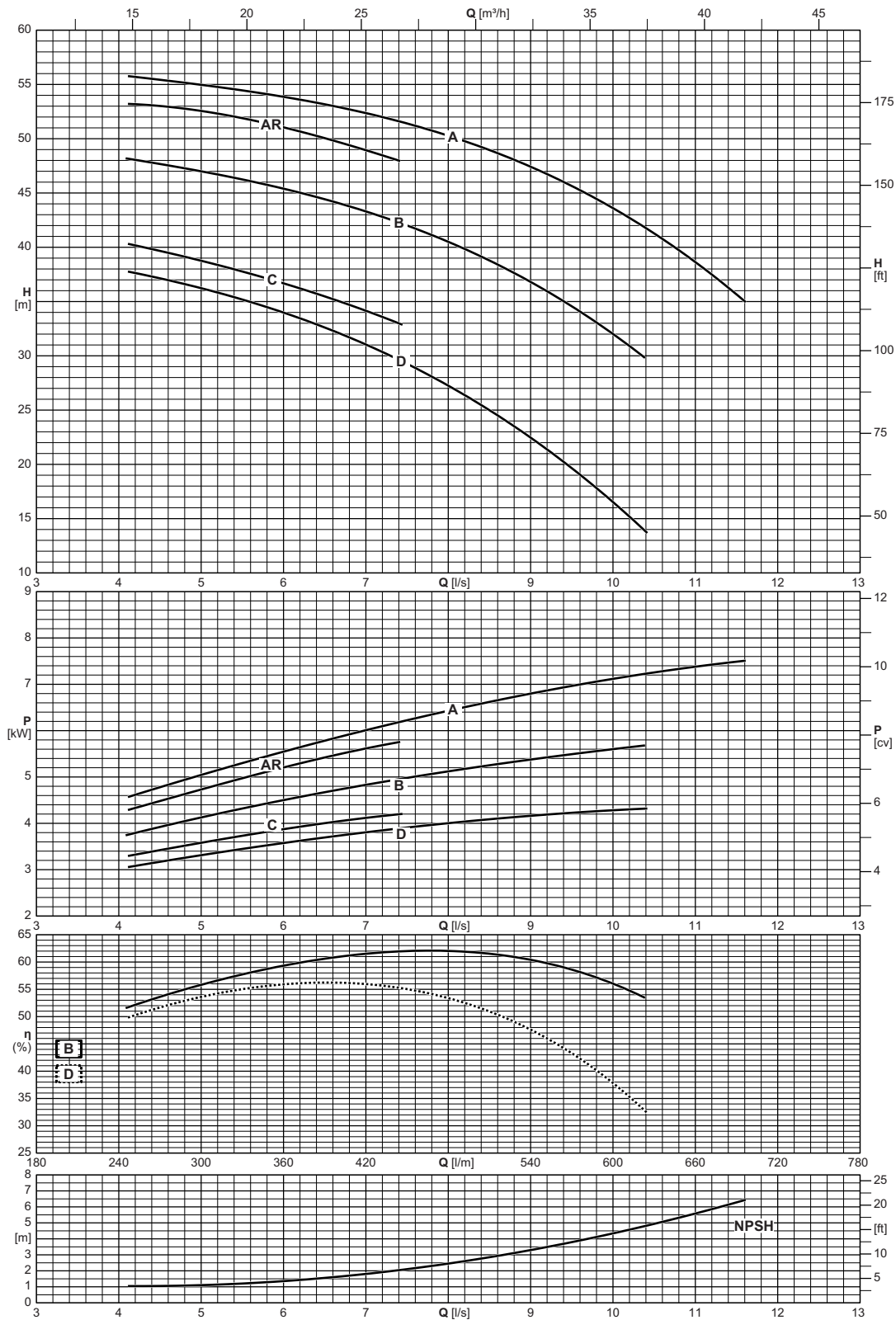

Type Тип Tipo	Inlet maximum pressure Макс. давление на всасывании Pressione massima in aspirazione
NCD2P40-200	[bar] 16

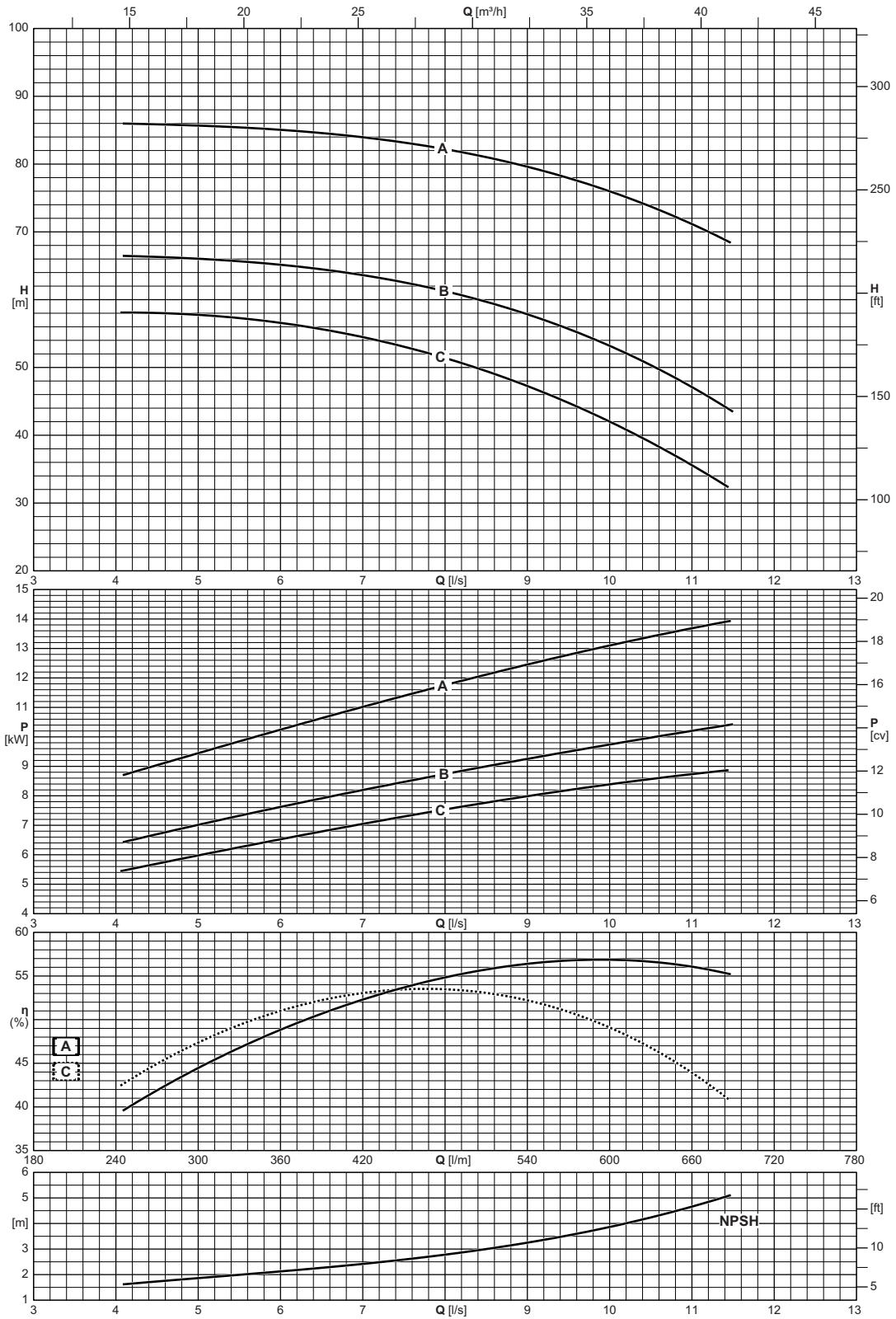

Type <i>Tun</i> Tipo	Inlet maximum pressure Макс. давление на всасывании Pressione massima in aspirazione
NCD2P40-250	[bar] 10

NCD 2P50-125

2900 n [min⁻¹]

ErP Ready



Operating data
Рабочие характеристики
Caratteristiche di funzionamento

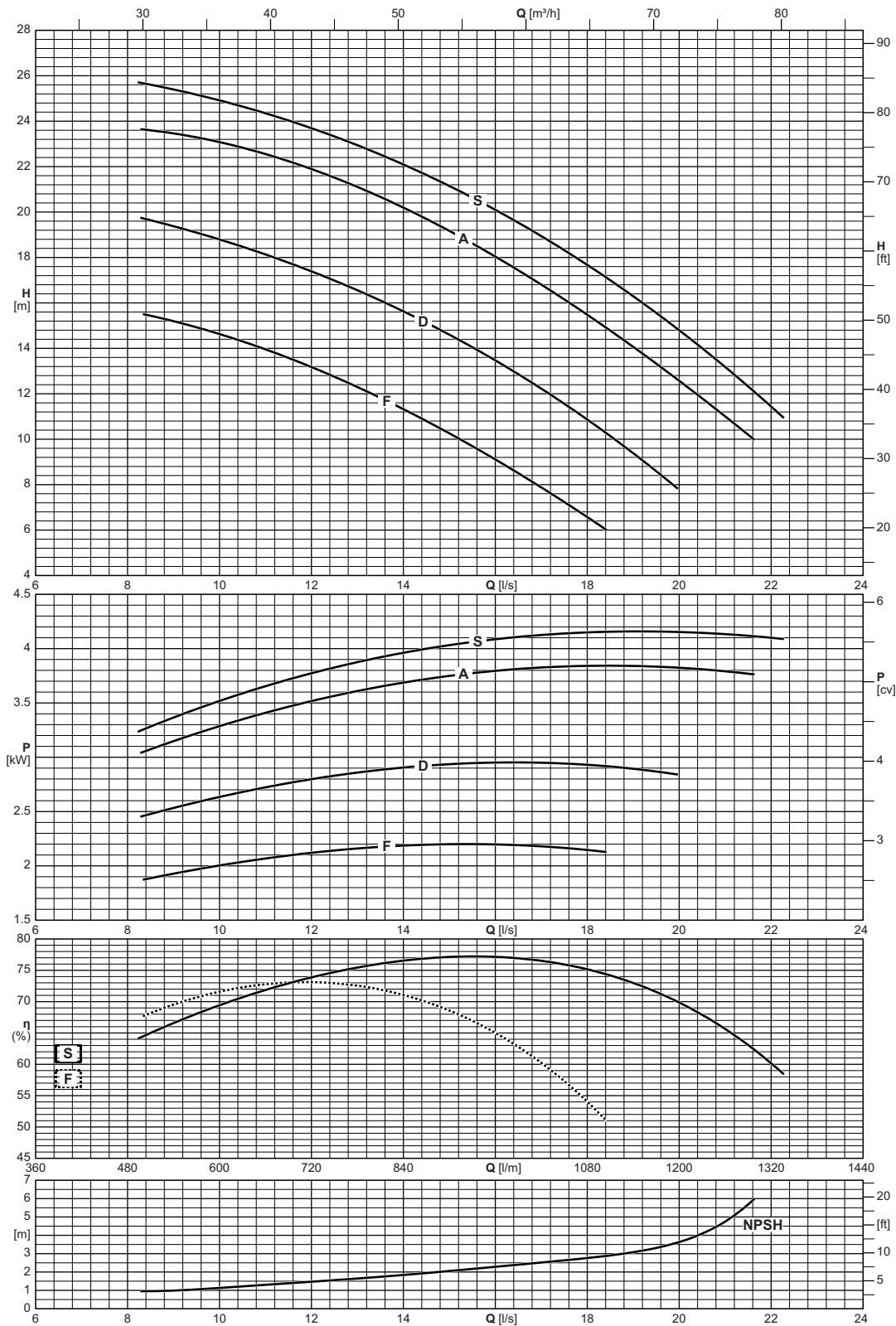

Type Тип Tipo	Inlet maximum pressure Макс. давление на всасывании Pressione massima in aspirazione
NCD2P50-125	[bar] 16

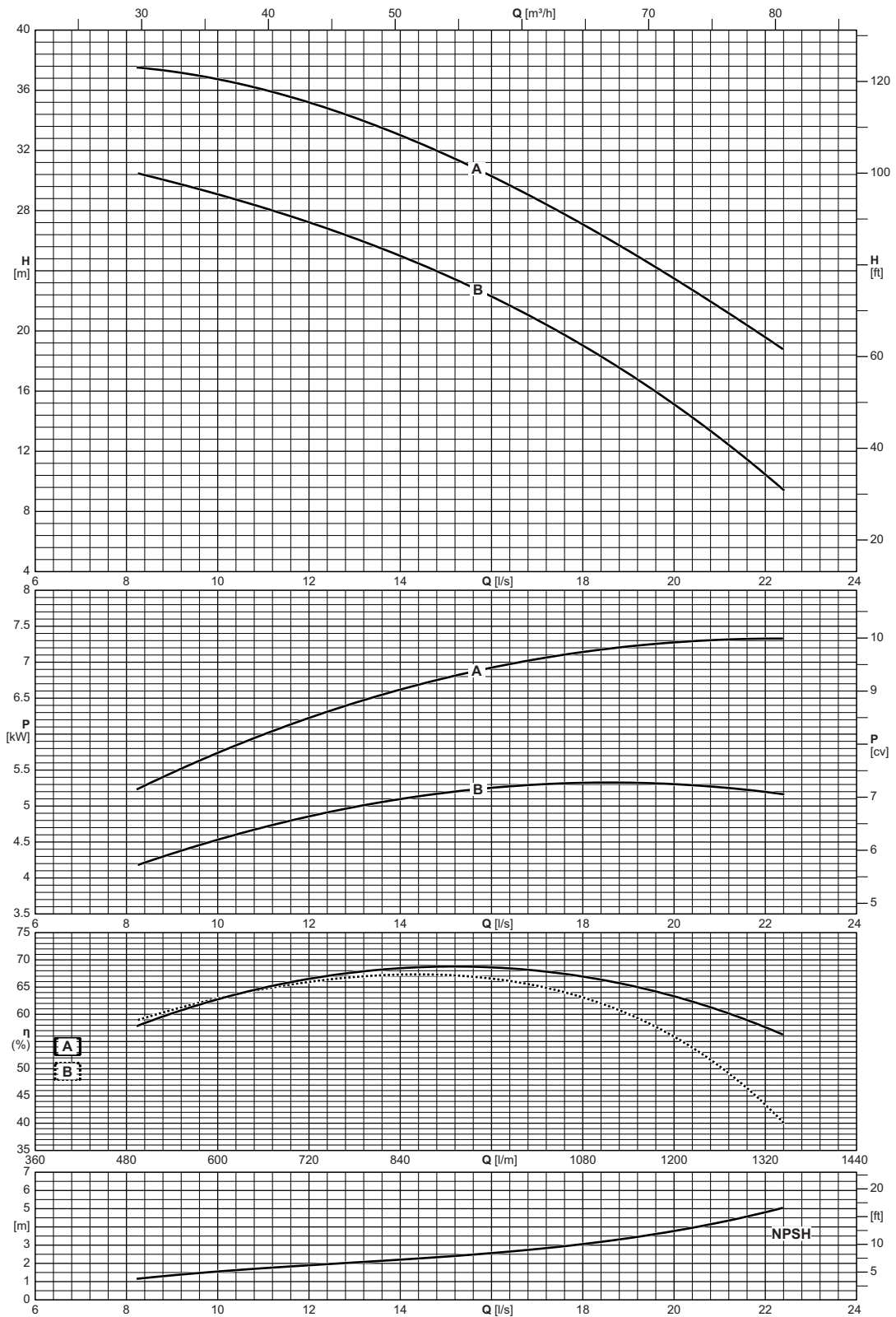

Type Typ Tipo	Inlet maximum pressure Макс. давление на всасывании Pressione massima in aspirazione
NCD2P50-160	[bar] 16

NCD 2P50-200

2900 n [min⁻¹]

ErP Ready



Operating data
Рабочие характеристики
Caratteristiche di funzionamento

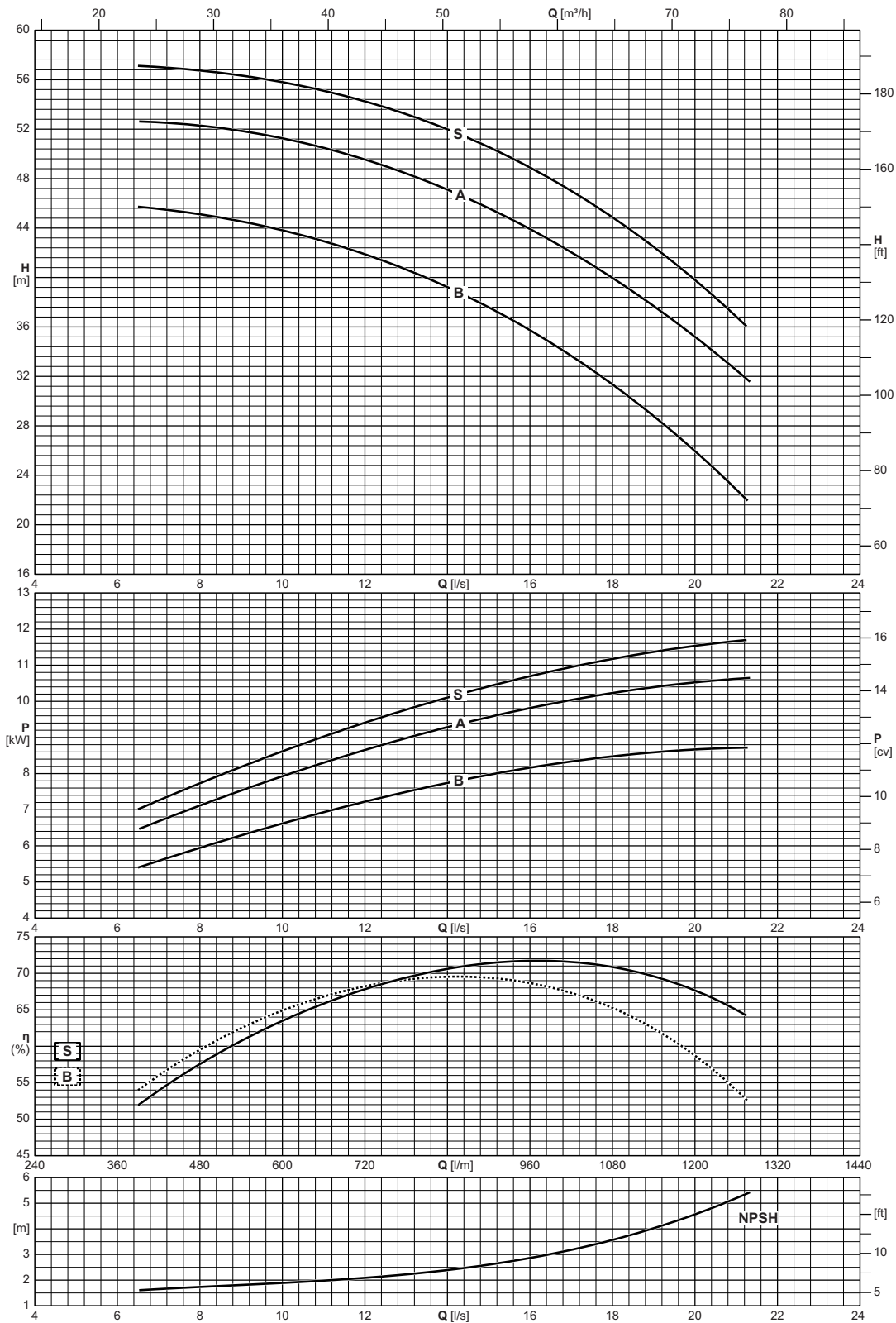

Type Тип Tipo	Inlet maximum pressure Макс. давление на всасывании Pressione massima in aspirazione
NCD2P50-200	[bar] 10

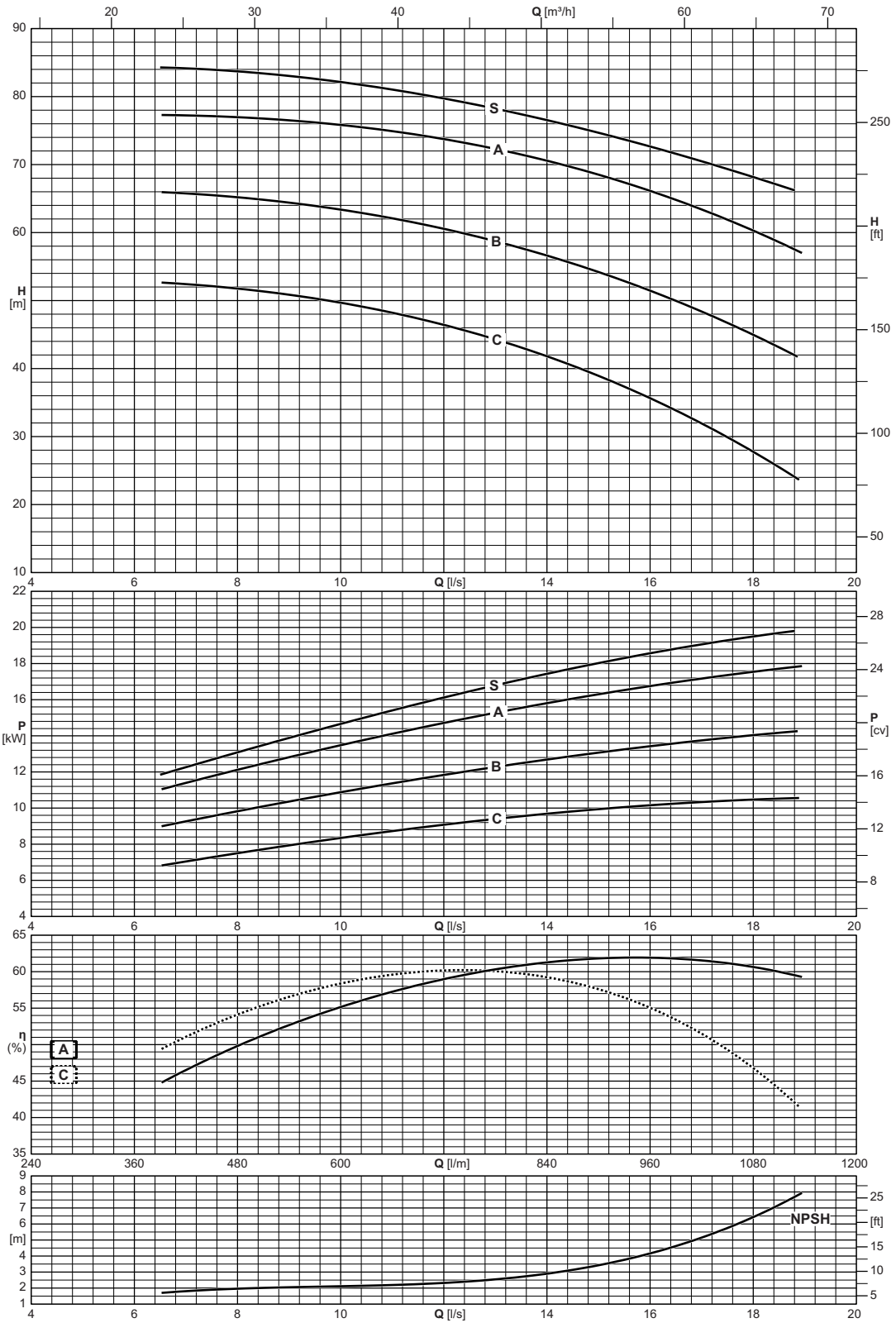

Type Тип Tipo	Inlet maximum pressure Макс. давление на всасывании Pressione massima in aspirazione
NCD2P50-250	[bar] 10

NCD 2P65-125

2900 n [min⁻¹]

ErP Ready



Operating data
Рабочие характеристики
Caratteristiche di funzionamento

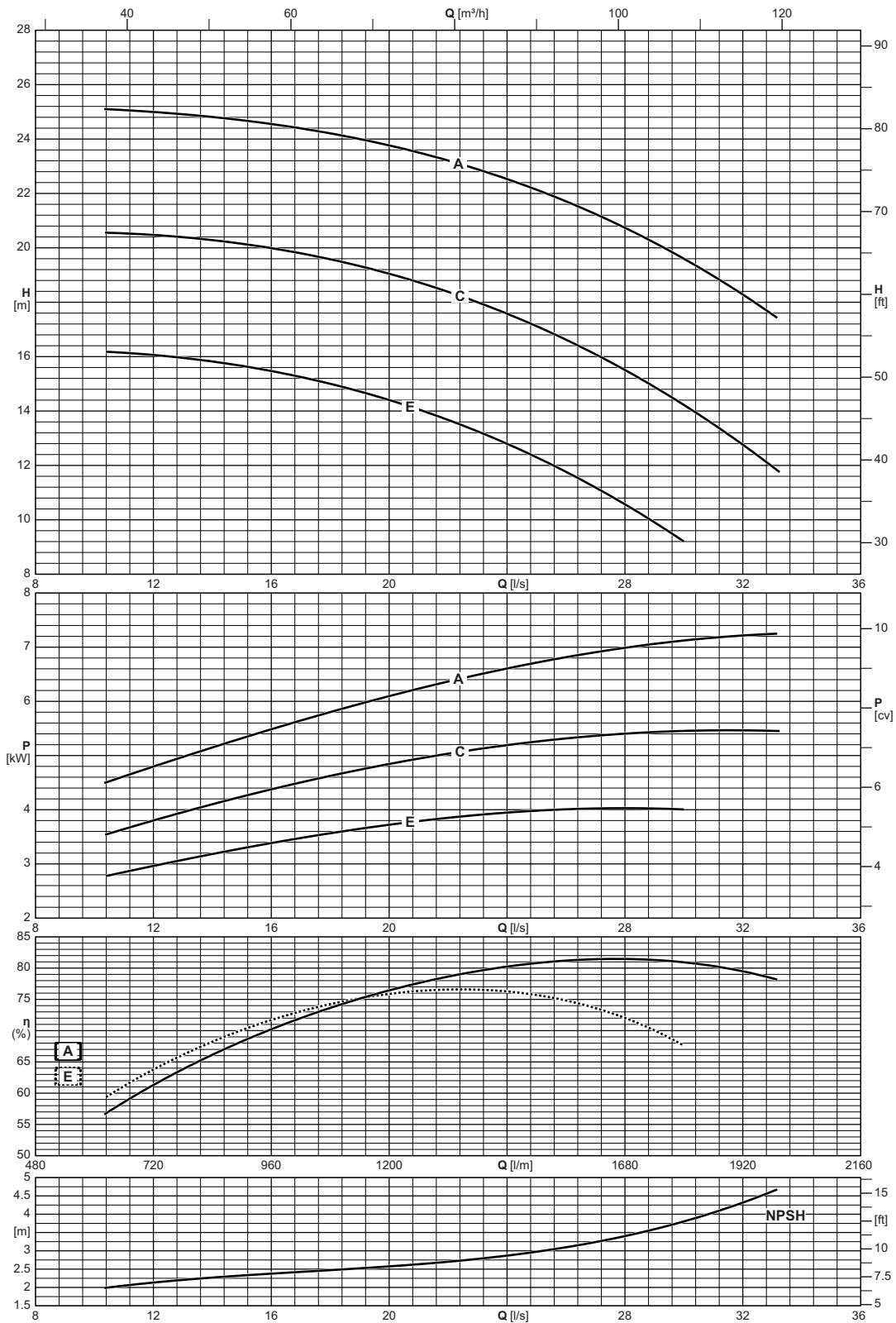

Type Тип Tipo	Inlet maximum pressure Макс. давление на всасывании Pressione massima in aspirazione
NCD2P65-125	[bar] 16

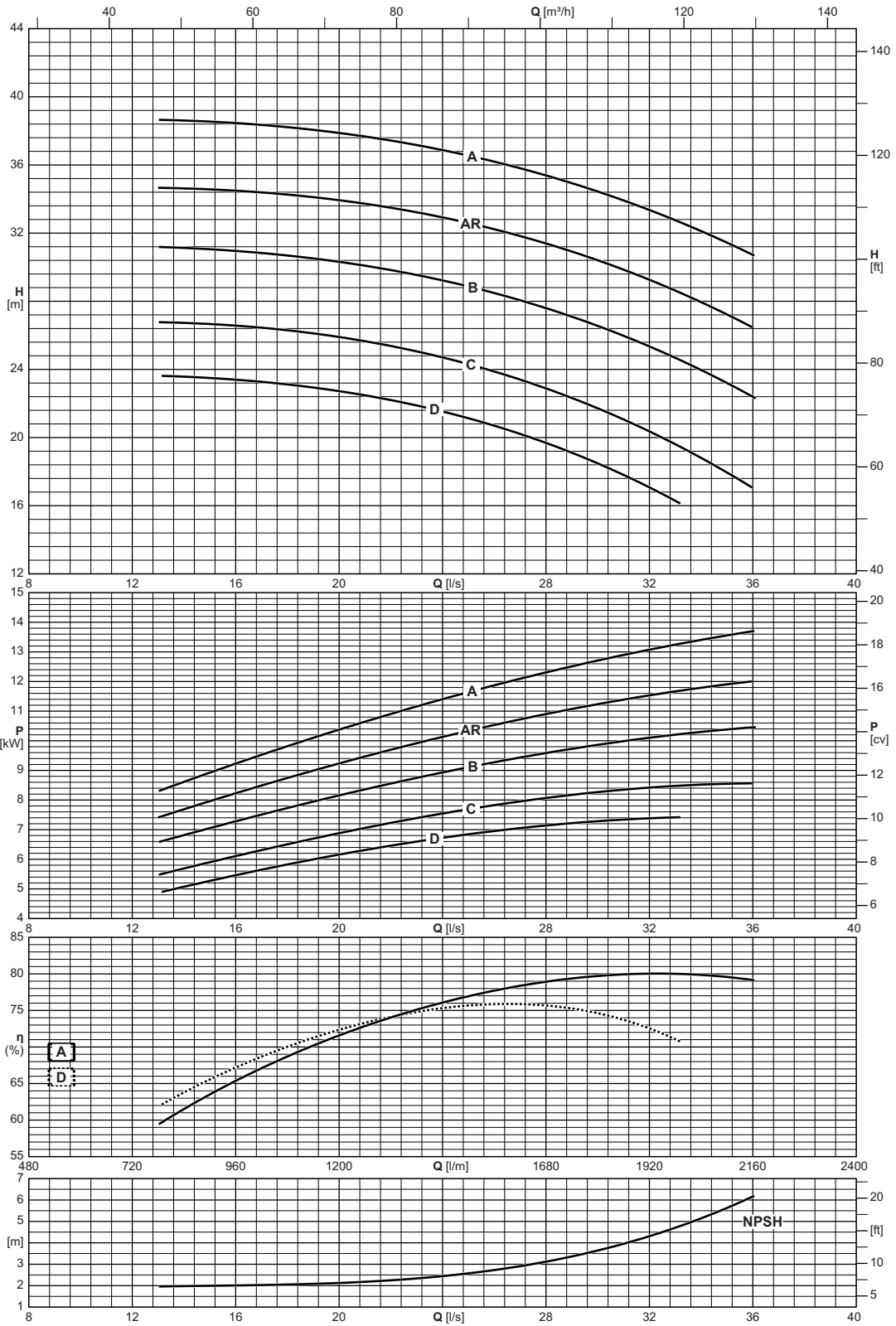

Type Тип Tipo	Inlet maximum pressure Макс. давление на всасывании Pressione massima in aspirazione
NCD2P65-160	[bar] 16

NCD 2P65-200

2900 n [min⁻¹]

ErP Ready



Operating data
Рабочие характеристики
Caratteristiche di funzionamento

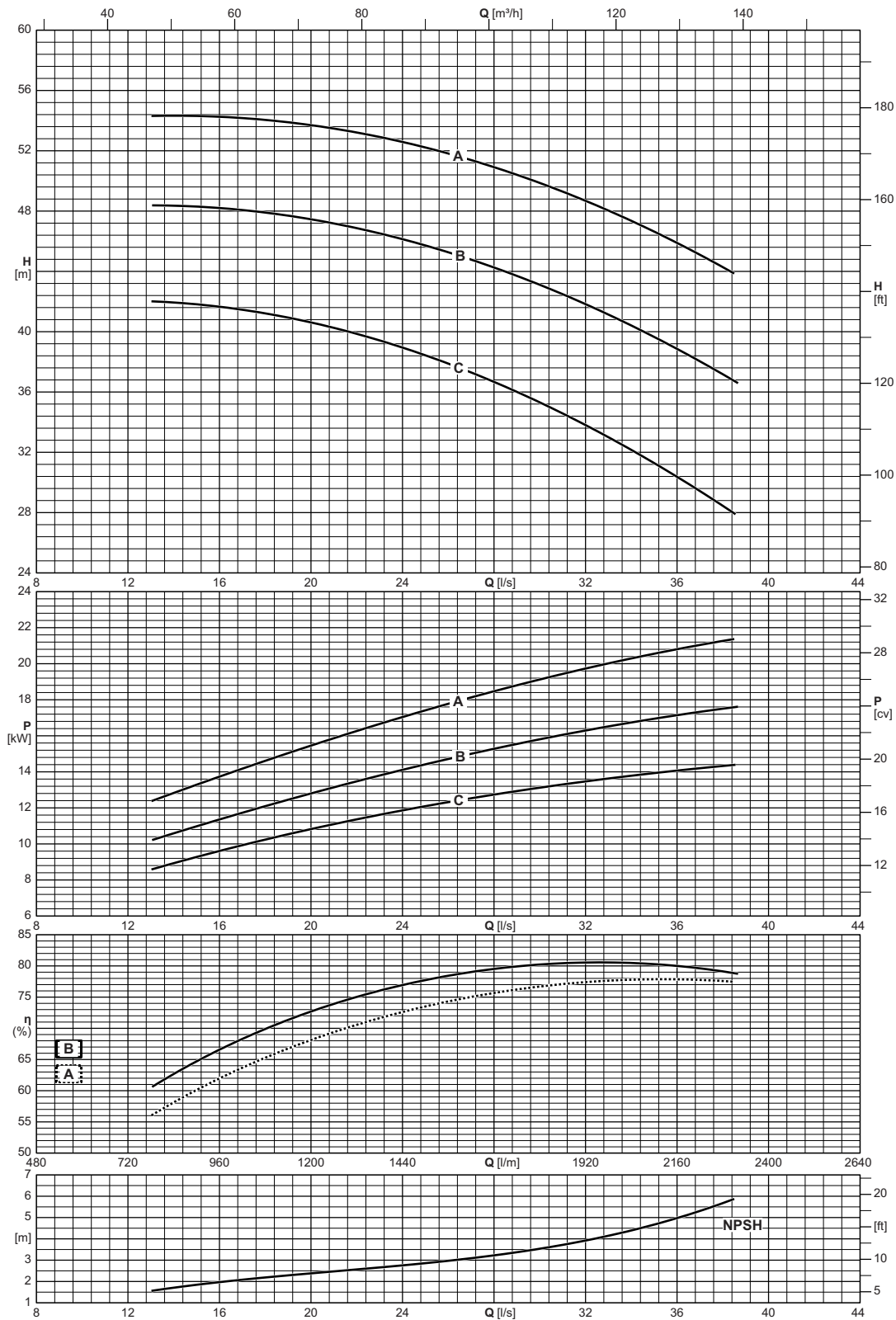

Type Тип Tipo	Inlet maximum pressure Макс. давление на всасывании Pressione massima in aspirazione
NCD2P65-200	[bar] 16

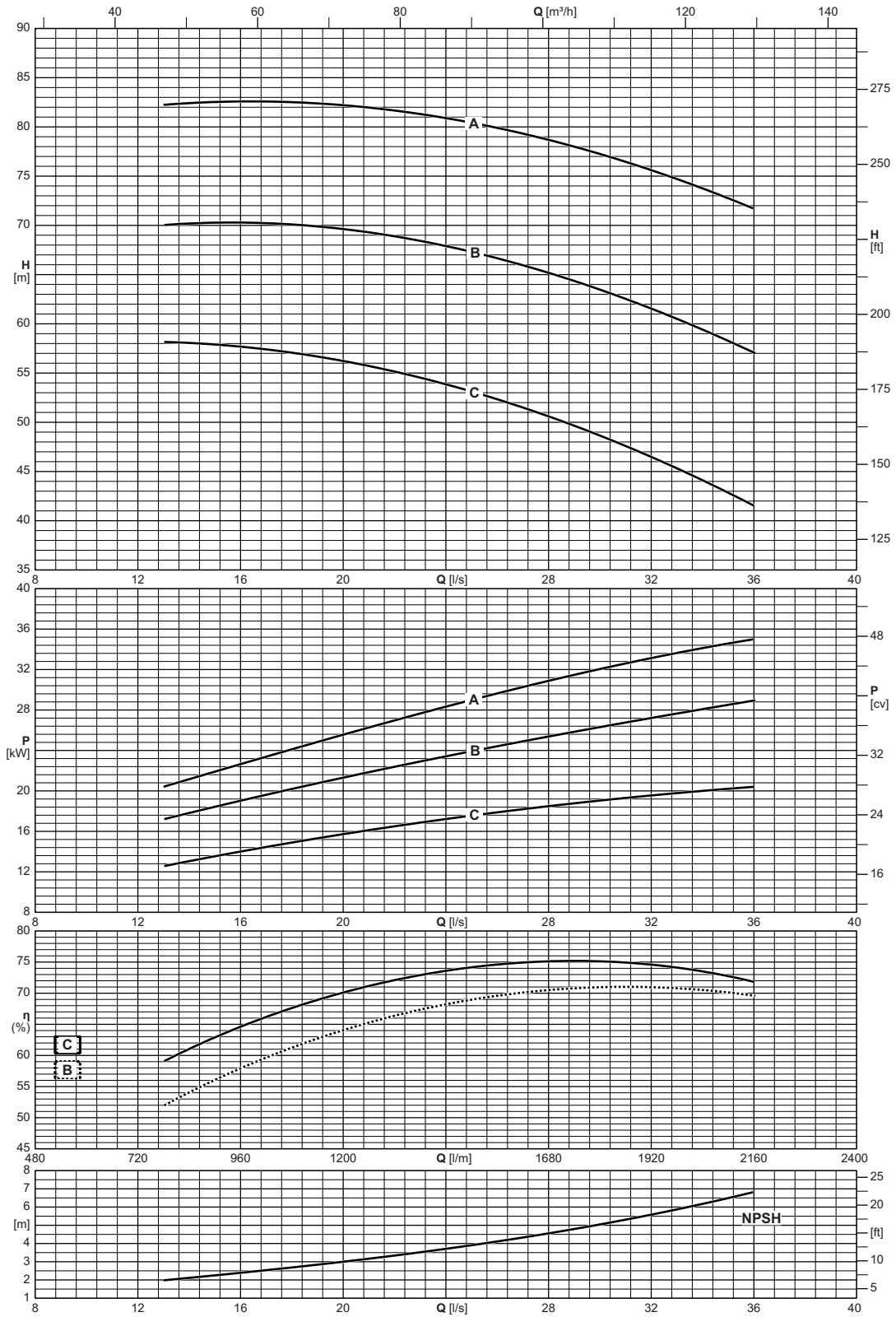

Type <i>Tun</i> Tipo	Inlet maximum pressure <i>Макс. давление на всасывании</i> Pressione massima in aspirazione
NCD2P65-250	[bar] 16

NCD 2P80-160

2900 n [min⁻¹]

ErP Ready



Operating data
Рабочие характеристики
Caratteristiche di funzionamento

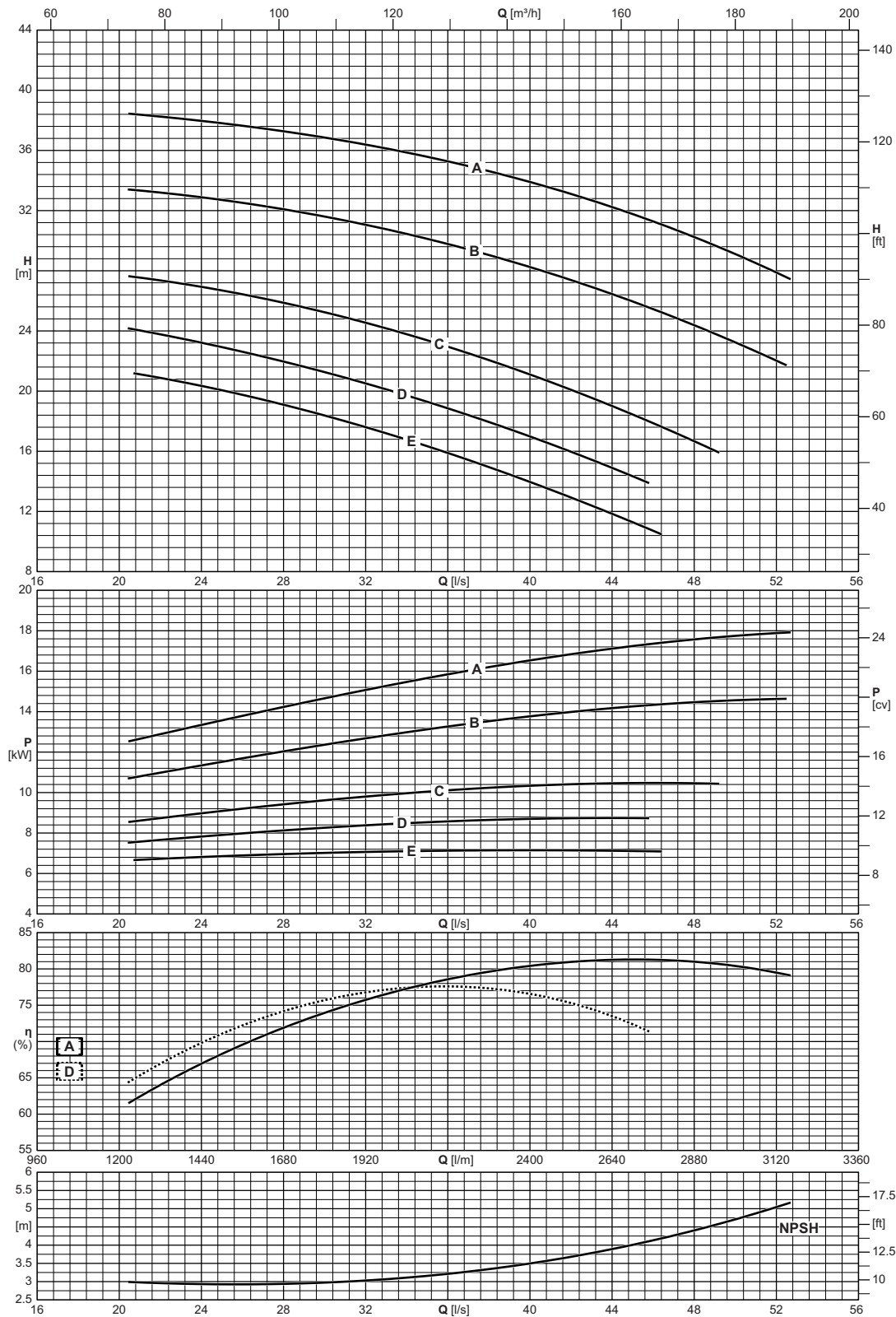

Type Тип Tipo	Inlet maximum pressure Макс. давление на всасывании Pressione massima in aspirazione
NCD2P80-160	[bar] 16

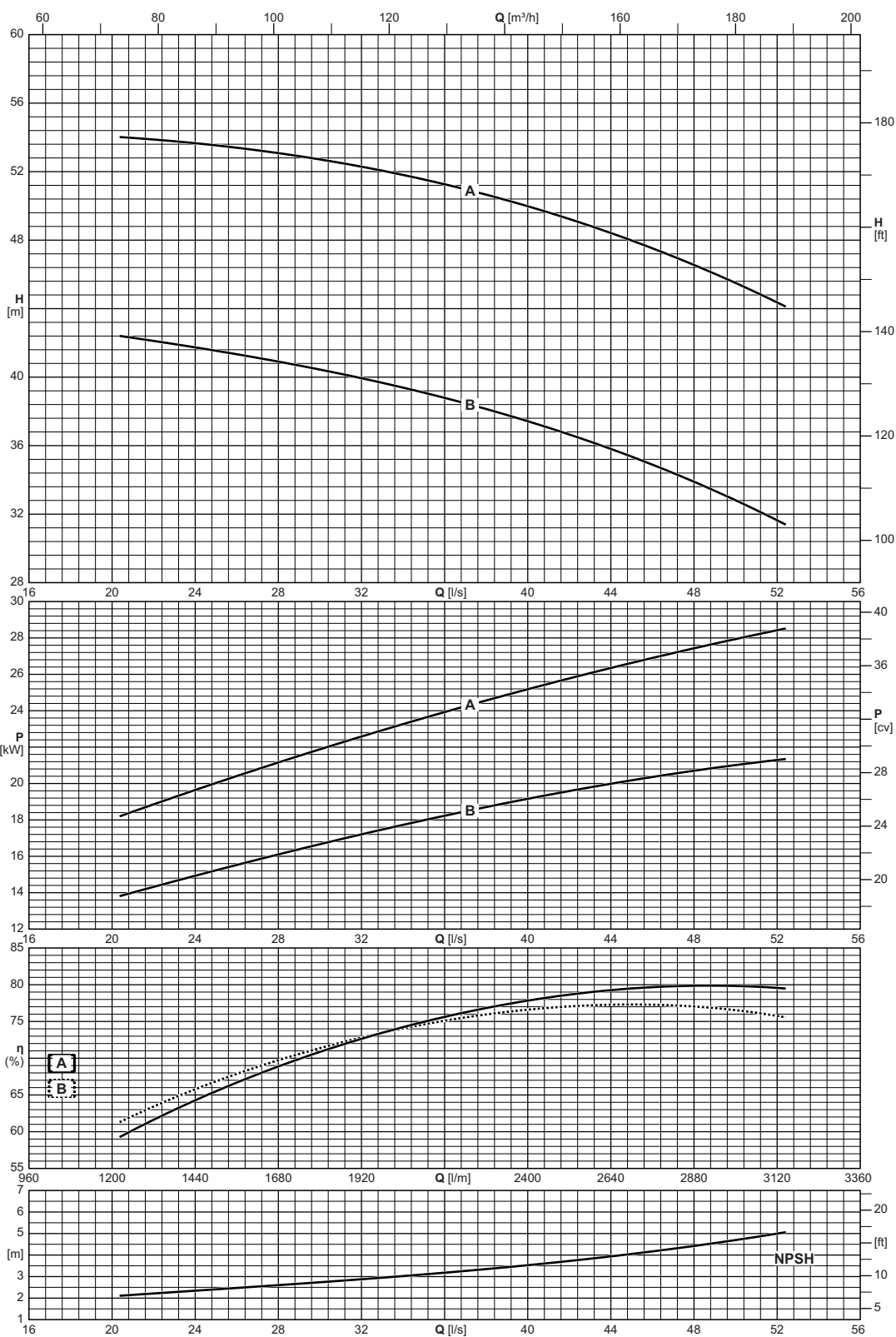

Type <i>Tun</i> Tipo	Inlet maximum pressure <i>Макс. давление на всасывании</i> Pressione massima in aspirazione
	[bar]
NCD2P80-200	10

NCD 2P80-250

2900 n [min⁻¹]

ErP Ready



Operating data
Рабочие характеристики
Caratteristiche di funzionamento

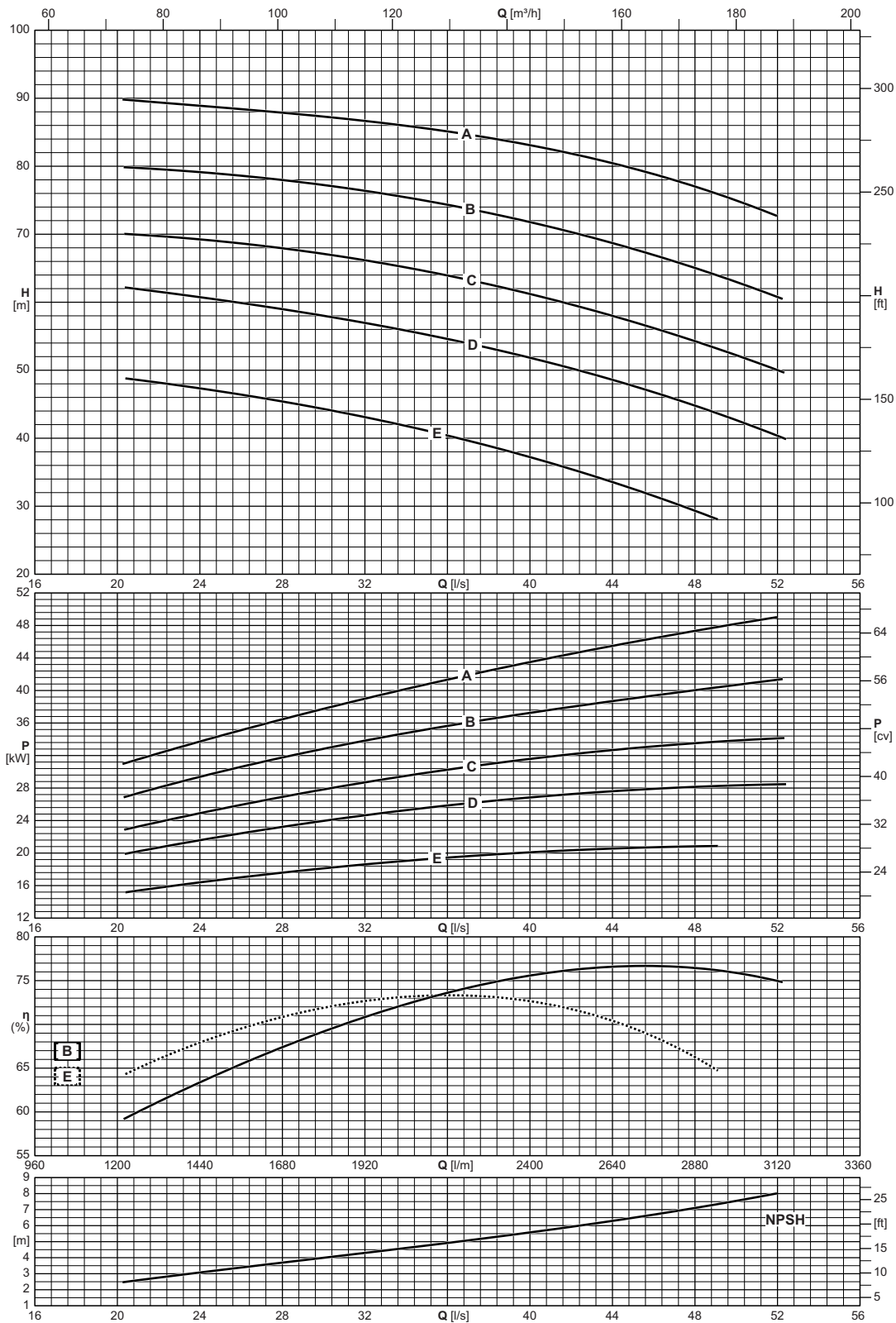

Type Тип Tipo	Inlet maximum pressure Макс. давление на всасывании Pressione massima in aspirazione
NCD2P80-250	[bar] 16

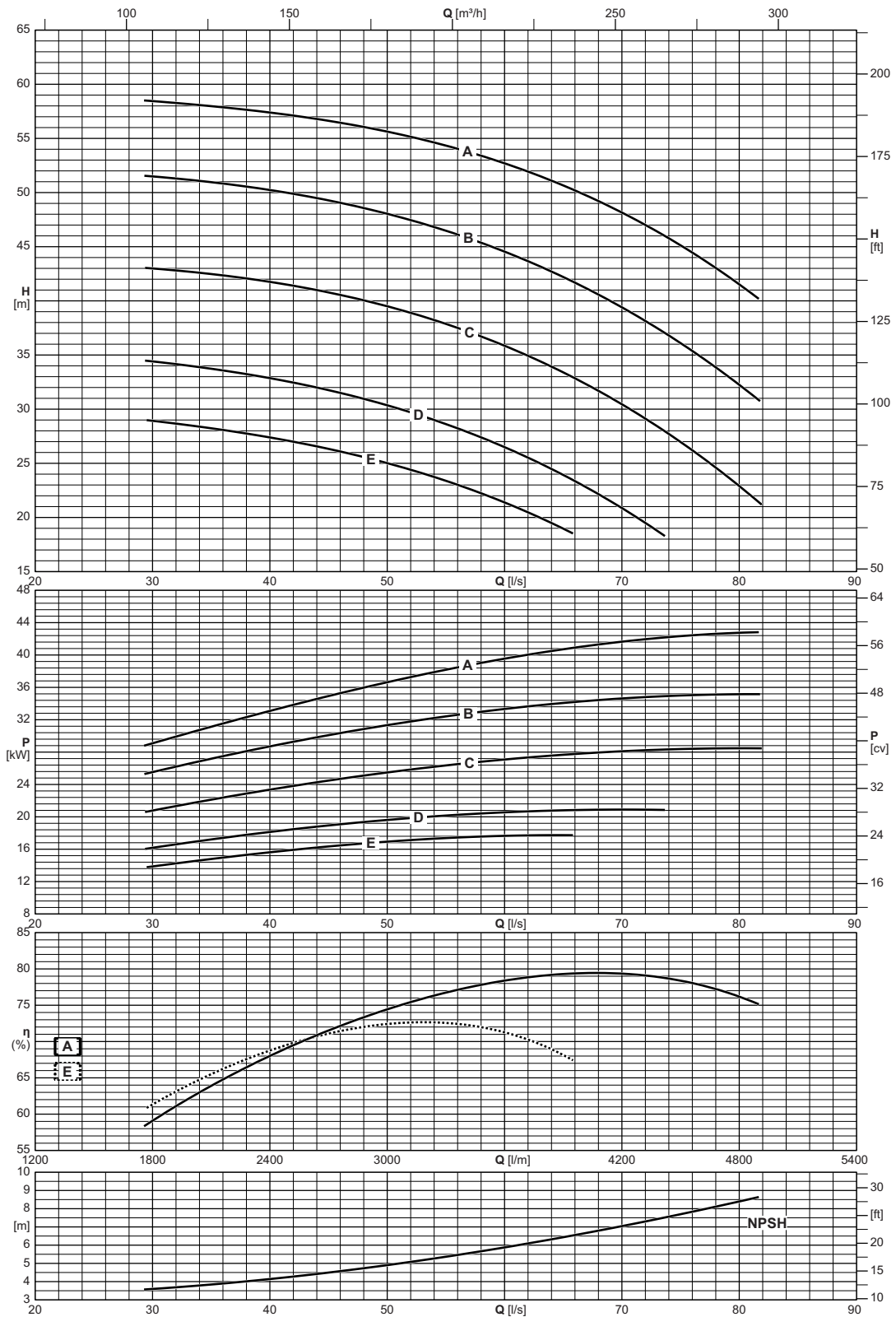

Type <i>Tun</i> Tipo	Inlet maximum pressure <i>Макс. давление на всасывании</i> Pressione massima in aspirazione
	[bar]
NCD2P100-200	16

NCD 2P100-250

2900 n [min⁻¹]

ErP Ready



Operating data
Рабочие характеристики
Caratteristiche di funzionamento

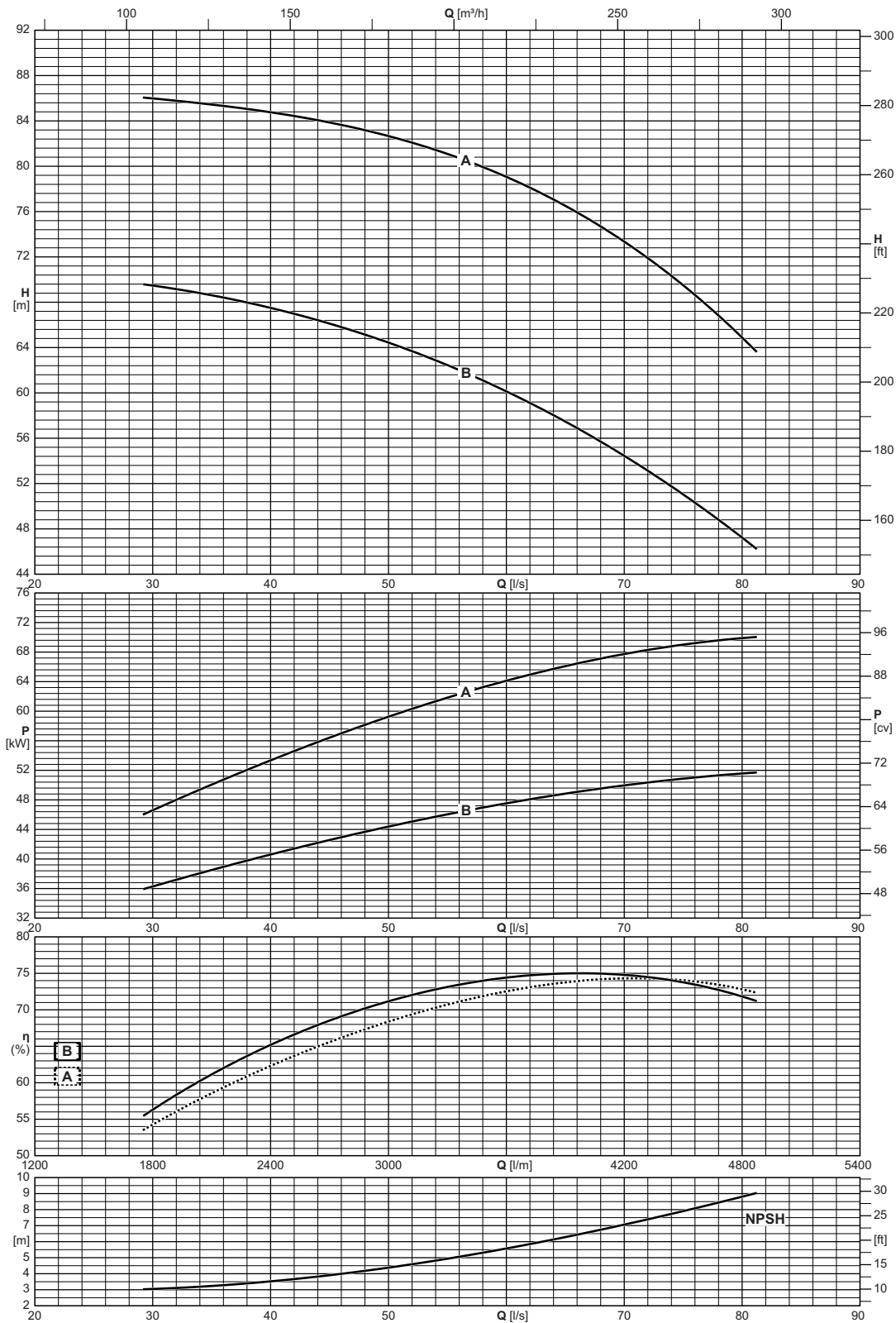

Type Тип Tipo	Inlet maximum pressure Макс. давление на всасывании Pressione massima in aspirazione
NCD2P100-250	[bar] 10

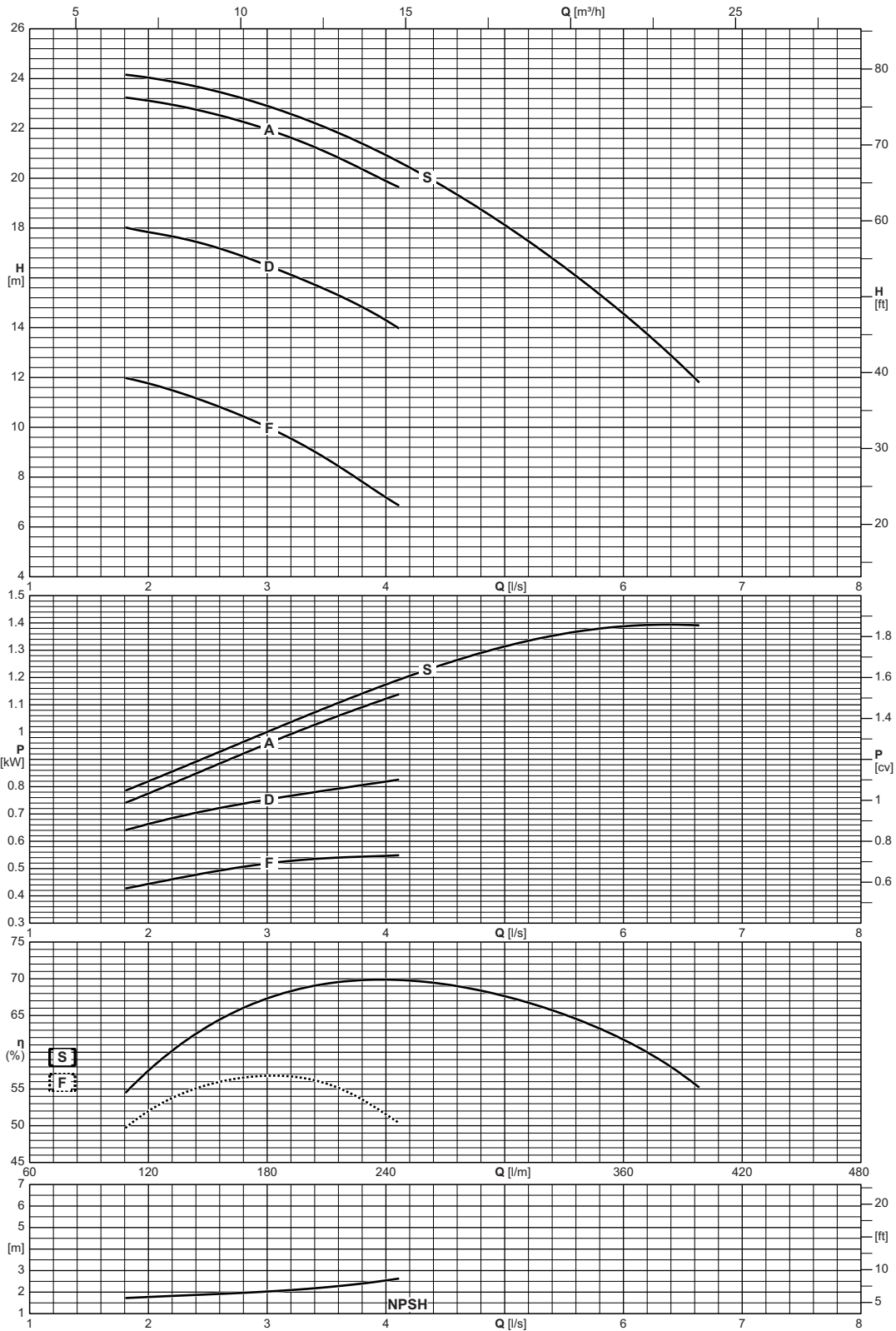

Type Typ Tipo	Inlet maximum pressure Макс. давление на всасывании Pressione massima in aspirazione
NCDS2P32-125	[bar] 10

Operating data
Рабочие характеристики
Caratteristiche di funzionamento

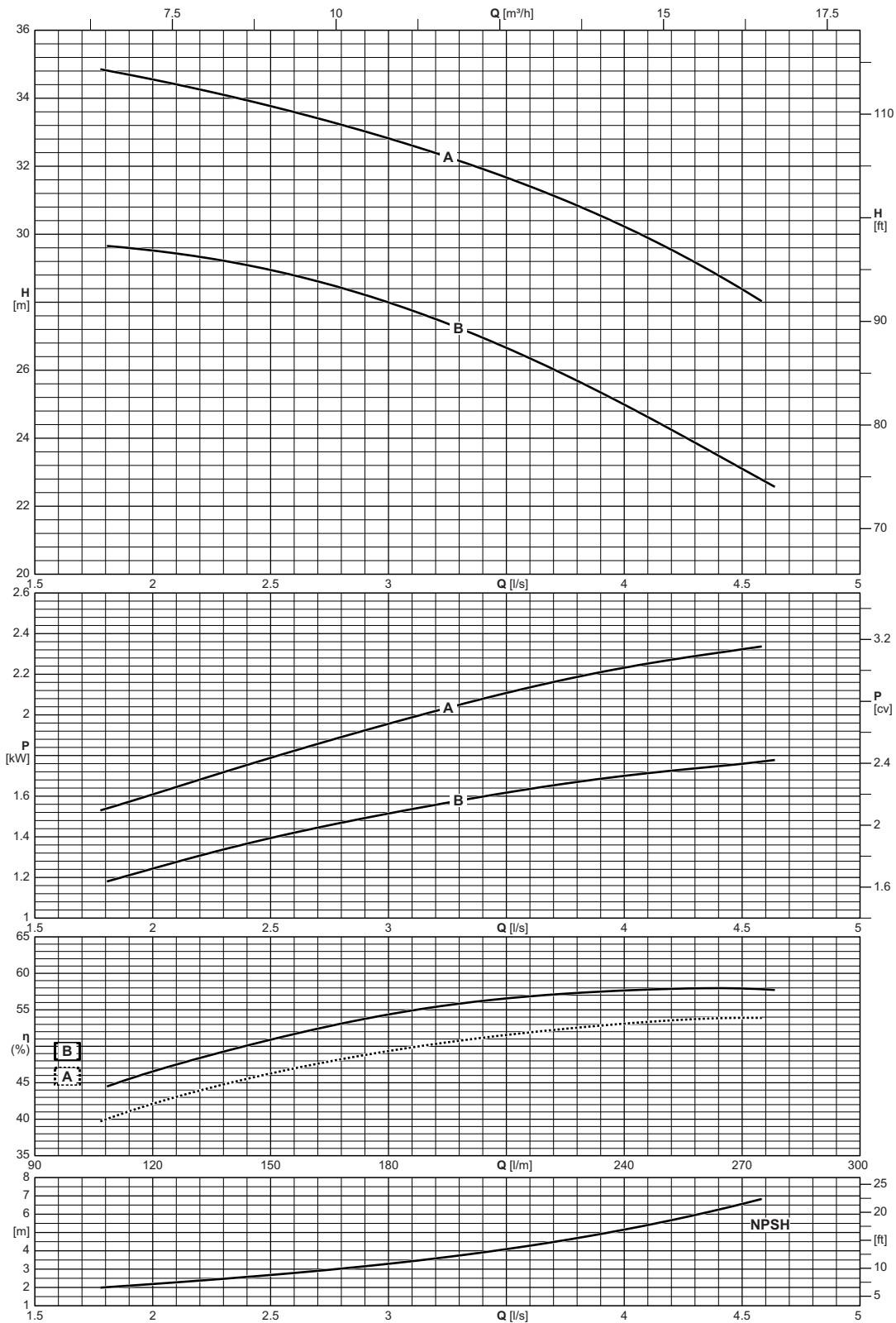

Type Тип Tipo	Inlet maximum pressure Макс. давление на всасывании Pressione massima in aspirazione
NCDS2P32-160	[bar] 10

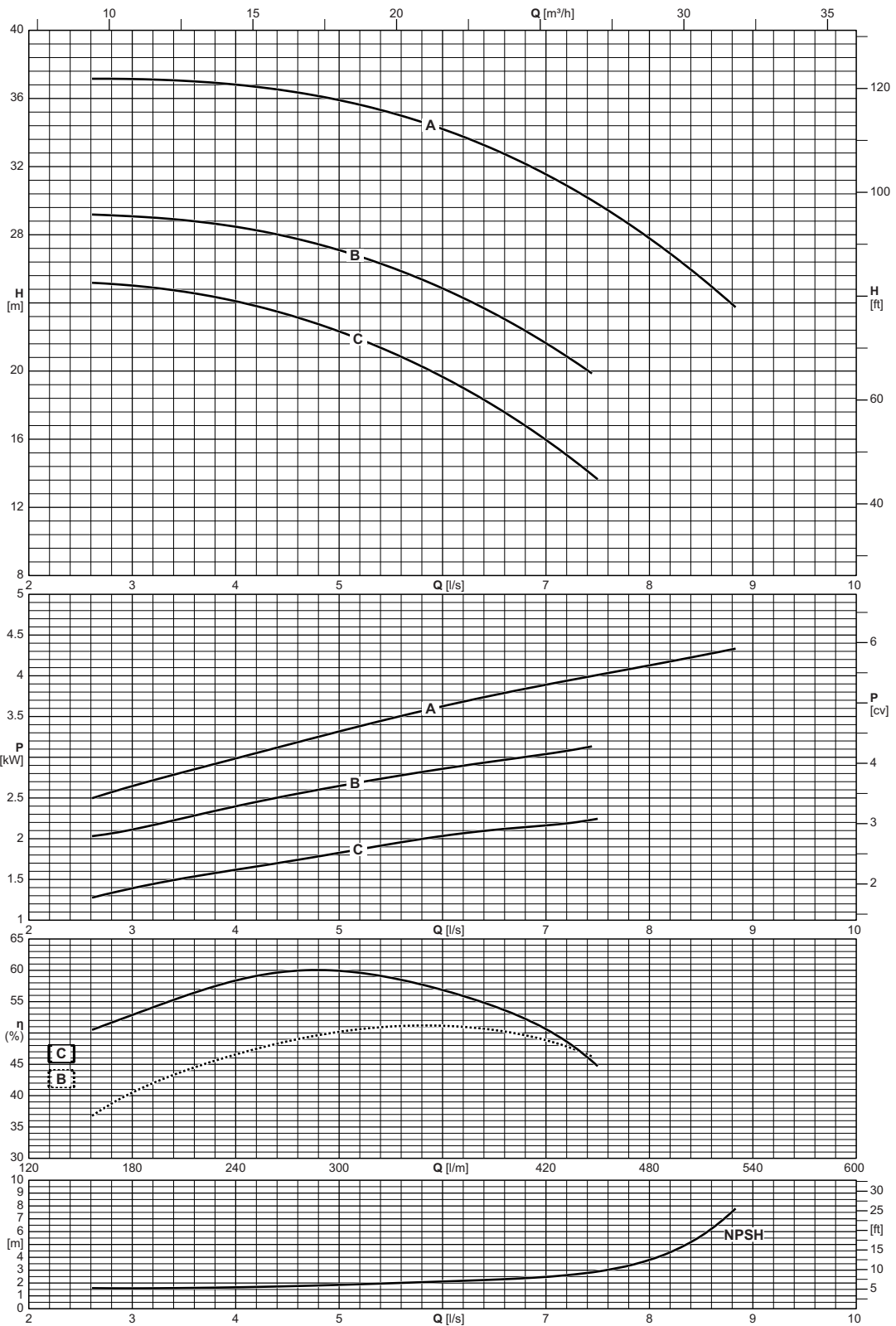

Type <i>Tun</i> Tipo	Inlet maximum pressure Макс. давление на всасывании Pressione massima in aspirazione
NCDS2P32L-160	[bar] 16

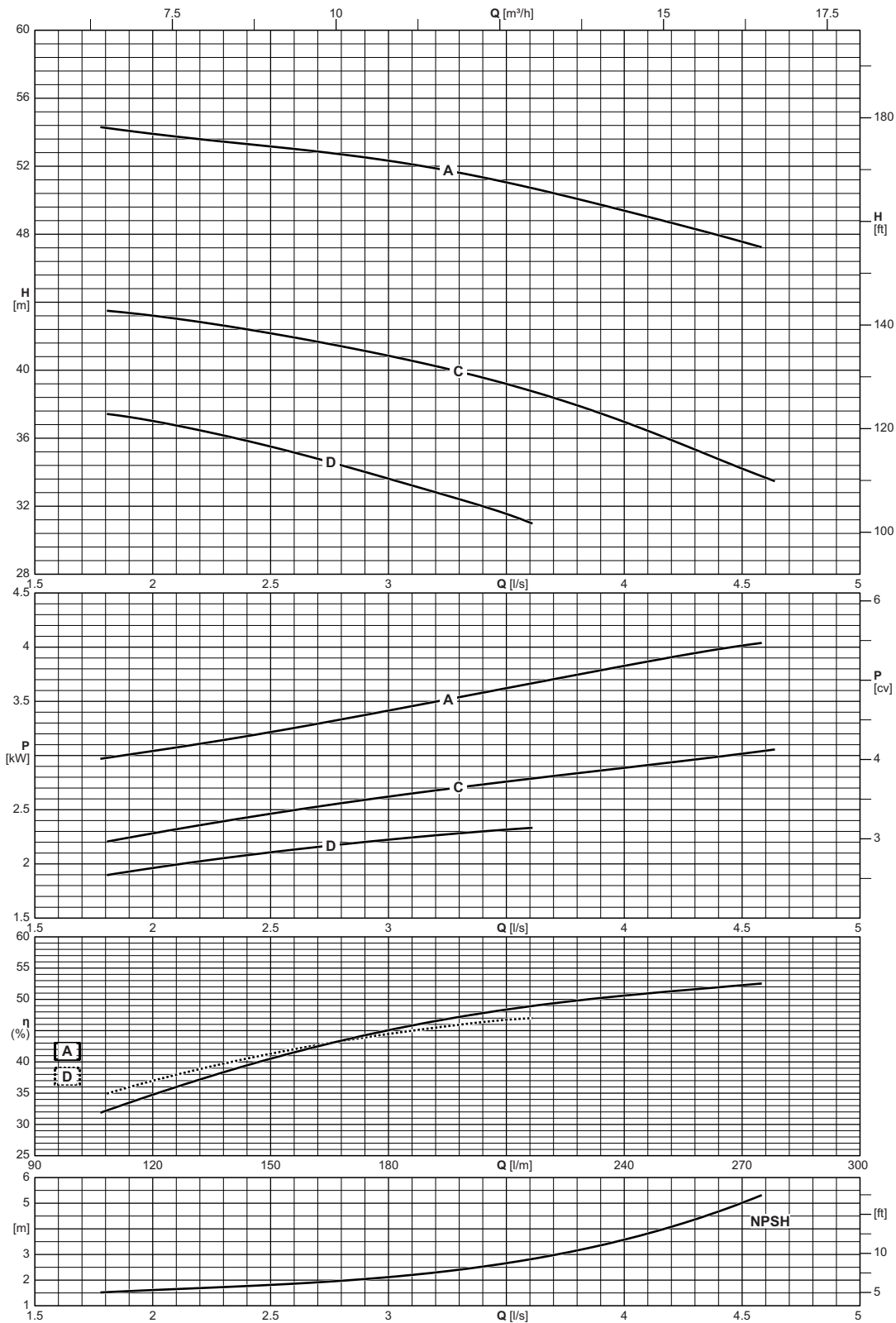

Type Тип Tipo	Inlet maximum pressure Макс. давление на всасывании Pressione massima in aspirazione
NCDS2P32-200	[bar] 10

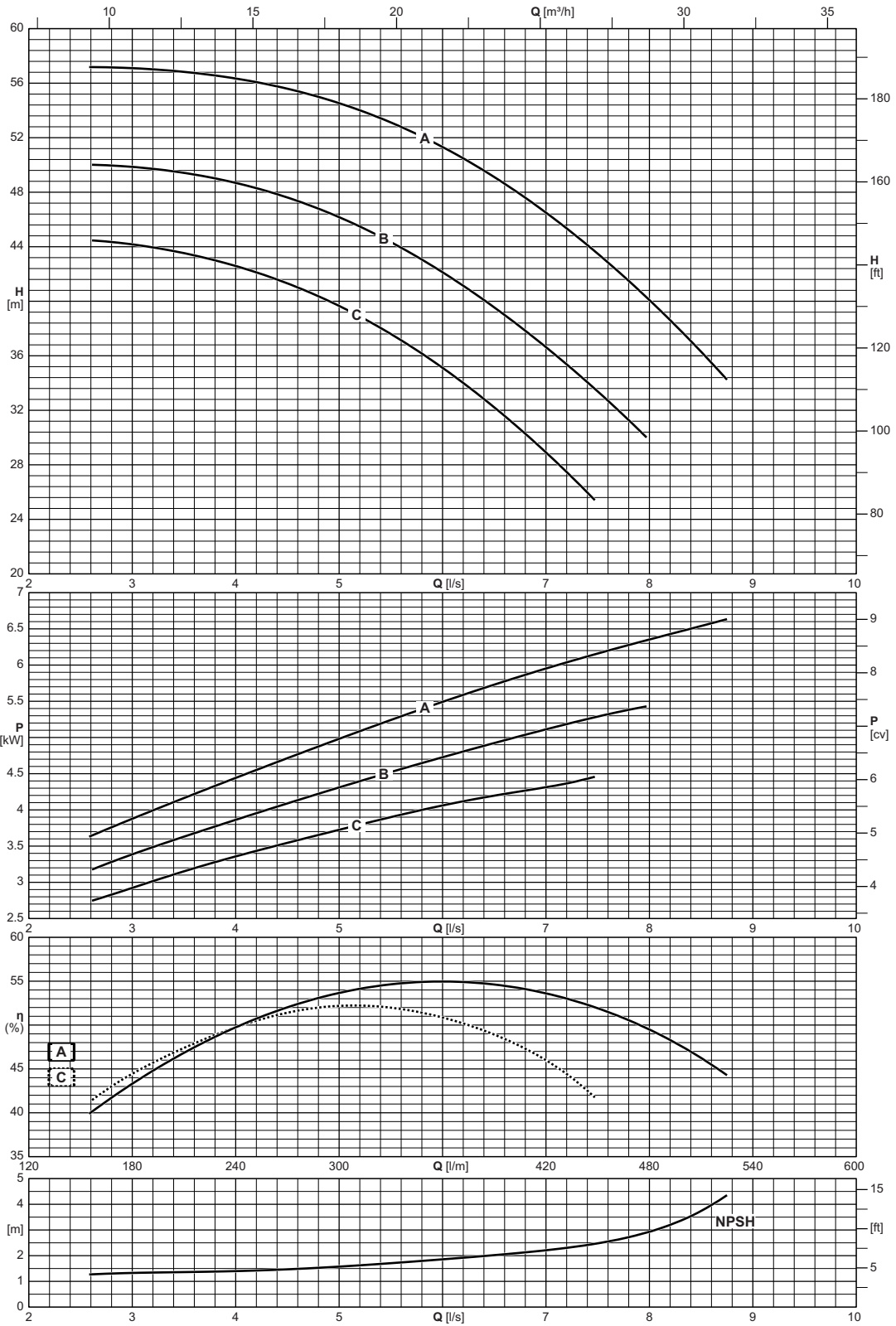

Type <i>Tun</i> Tipo	Inlet maximum pressure <i>Макс. давление на всасывании</i> Pressione massima in aspirazione
NCDS2P32L-200	[bar] 16

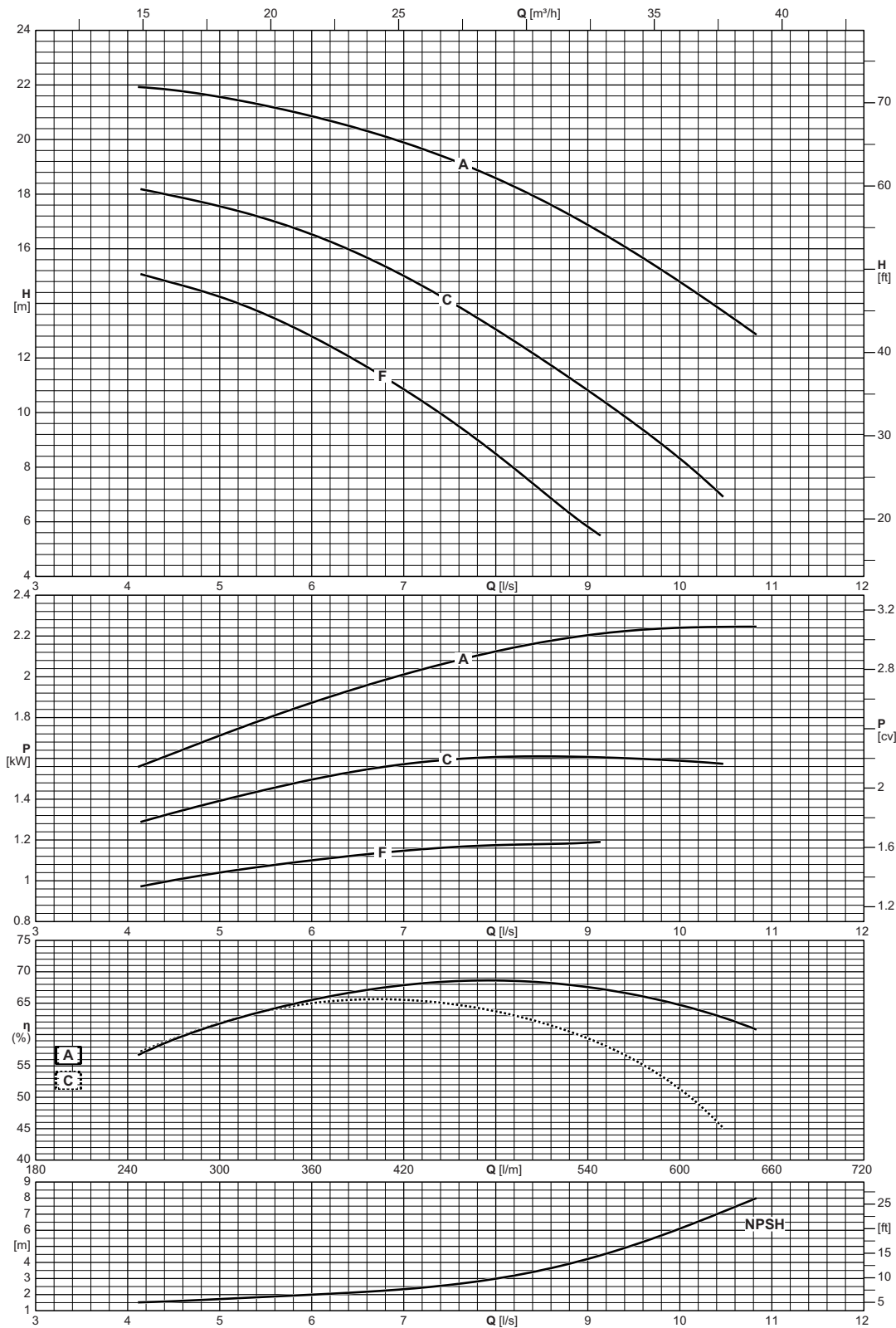

Type Тип Tipo	Inlet maximum pressure Макс. давление на всасывании Pressione massima in aspirazione
NCDS2P40-125	[bar] 10

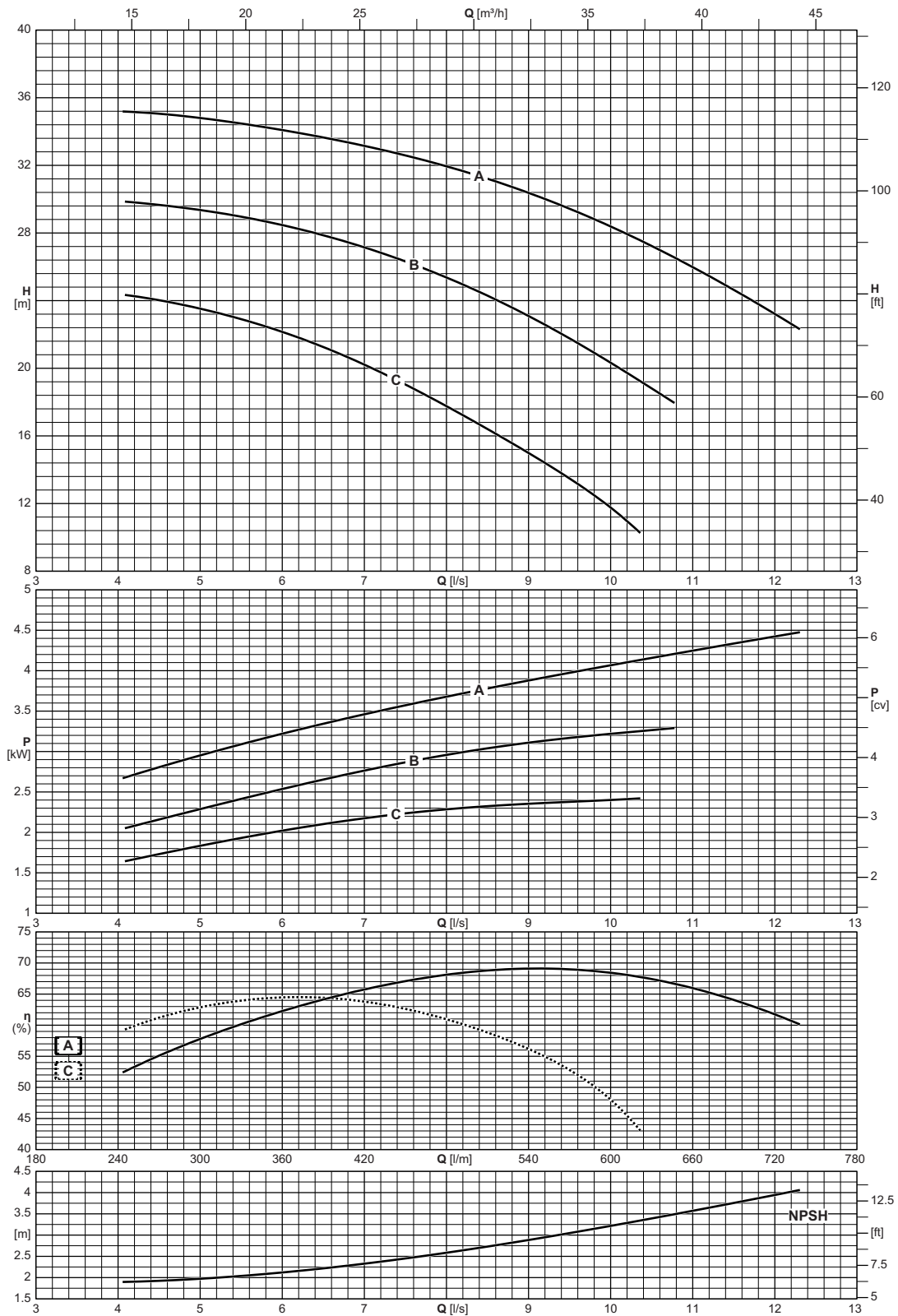

Type <i>Tun</i> Tipo	Inlet maximum pressure <i>Макс. давление на всасывании</i> Pressione massima in aspirazione
NCDS2P40-160	[bar] 16

NCDS 2P40-200

3450 n [min⁻¹]

ErP Ready



Operating data
Рабочие характеристики
Caratteristiche di funzionamento

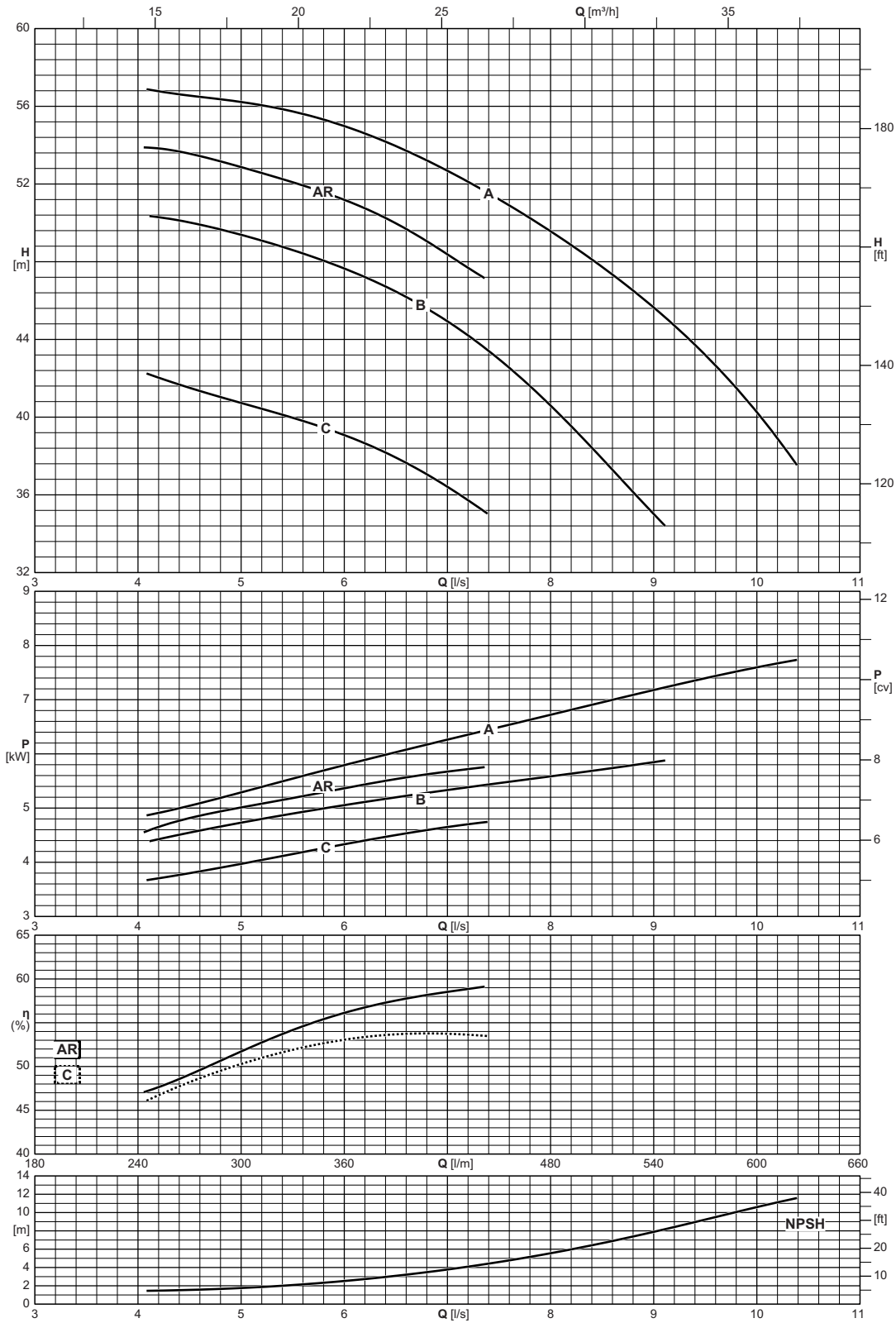

Type Тип Tipo	Inlet maximum pressure Макс. давление на всасывании Pressione massima in aspirazione
NCDS2P40-200	[bar] 16

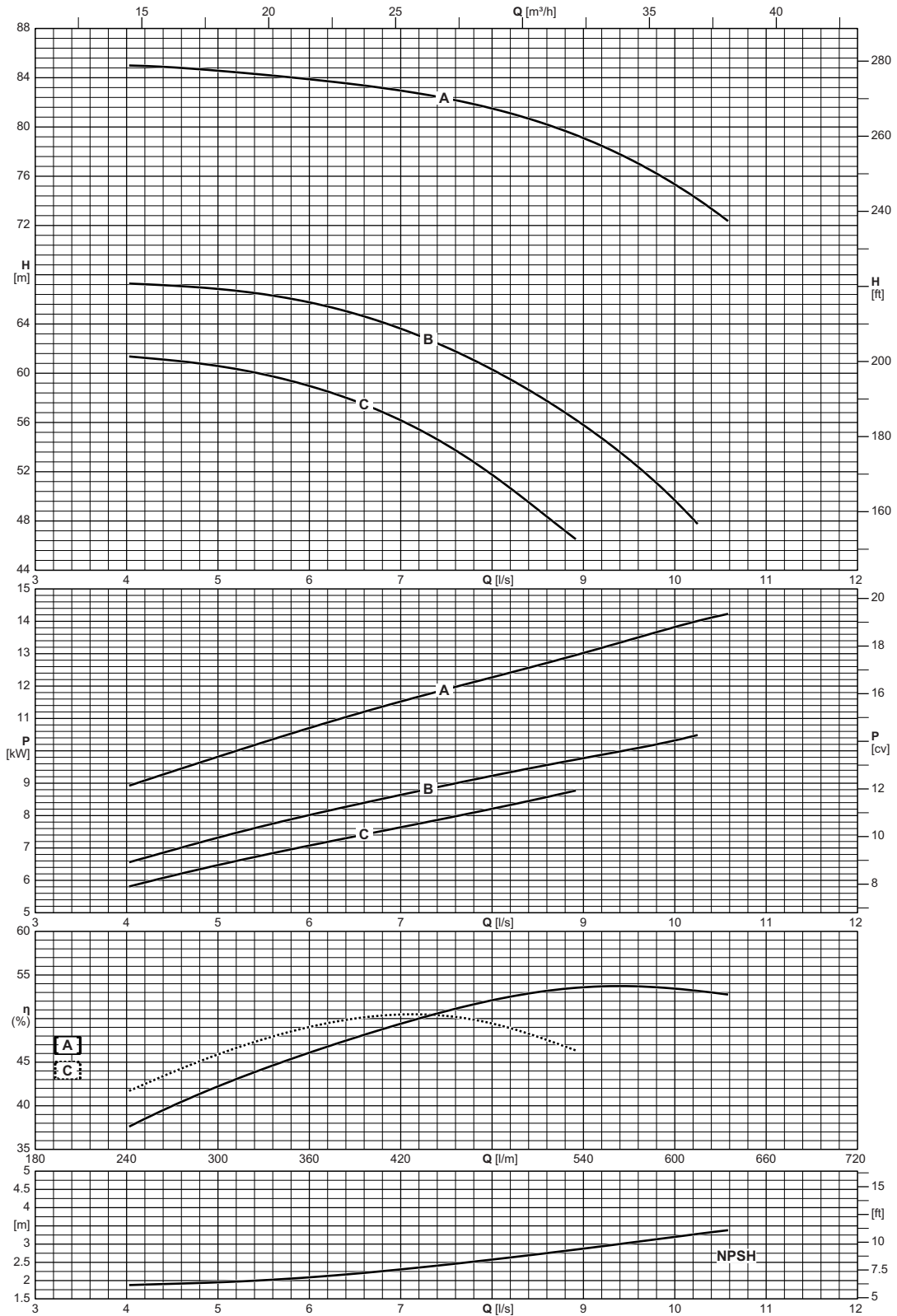

Type Typ Tipo	Inlet maximum pressure Макс. давление на всасывании Pressione massima in aspirazione
NCDS2P40-250	[bar] 10

NCDS 2P50-125

3450 n [min⁻¹]

ErP Ready



Operating data
Рабочие характеристики
Caratteristiche di funzionamento

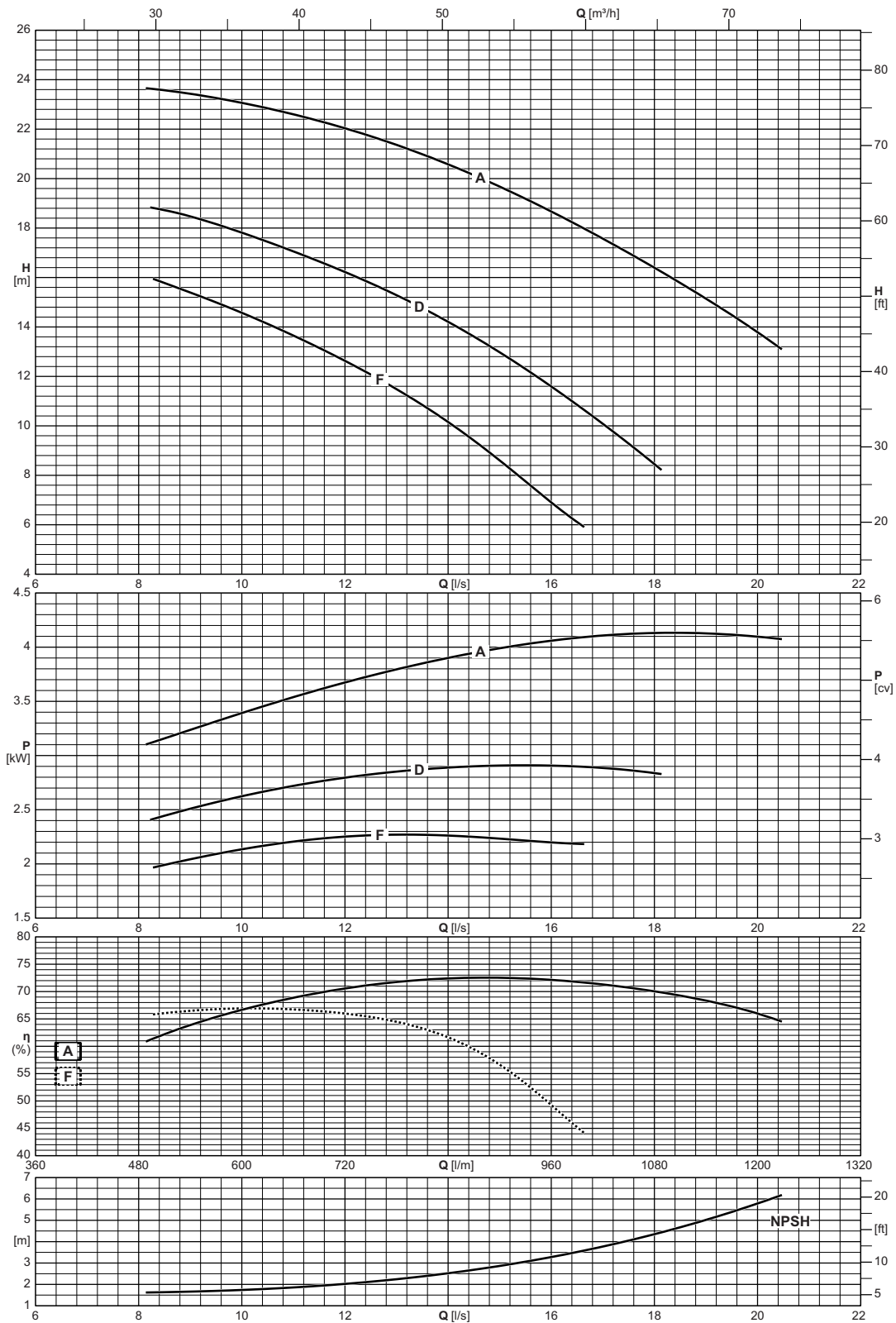

Type Тип Tipo	Inlet maximum pressure Макс. давление на всасывании Pressione massima in aspirazione
NCDS2P50-125	[bar] 16

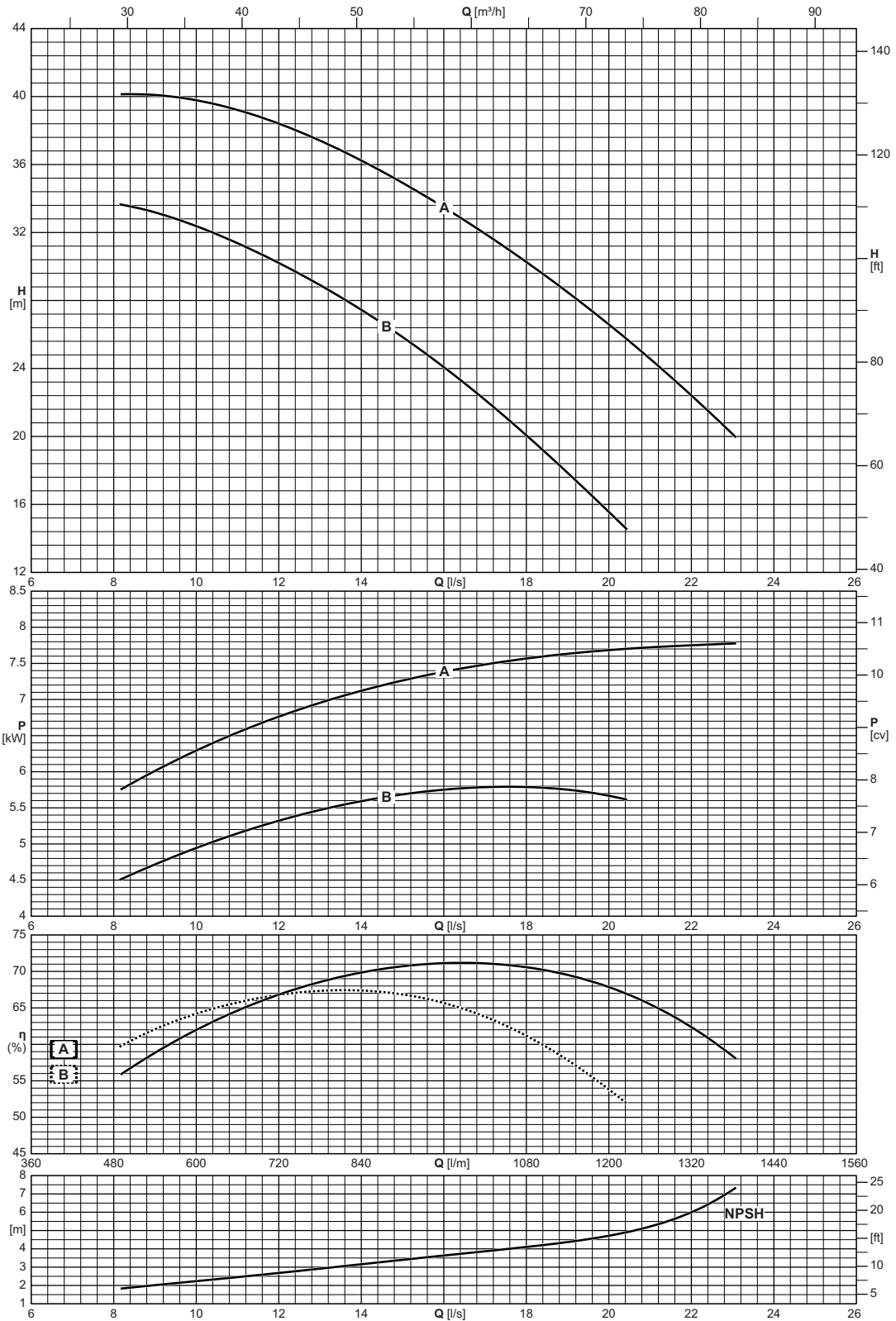

Type <i>Tun</i> Tipo	Inlet maximum pressure <i>Макс. давление на всасывании</i> Pressione massima in aspirazione
NCDS2P50-160	[bar] 16

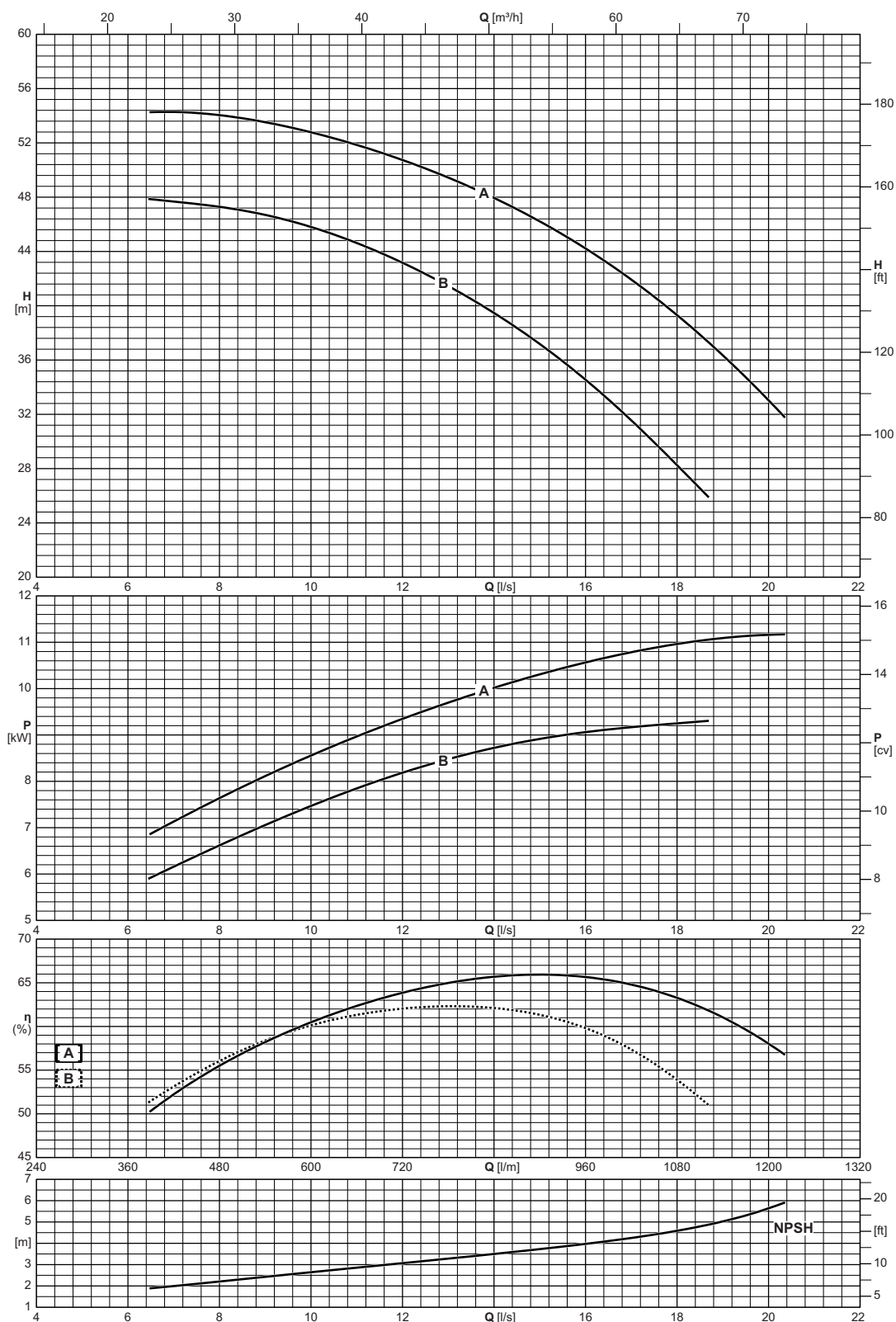

Type Тип Tipo	Inlet maximum pressure Макс. давление на всасывании Pressione massima in aspirazione
NCDS2P50-200	[bar] 10

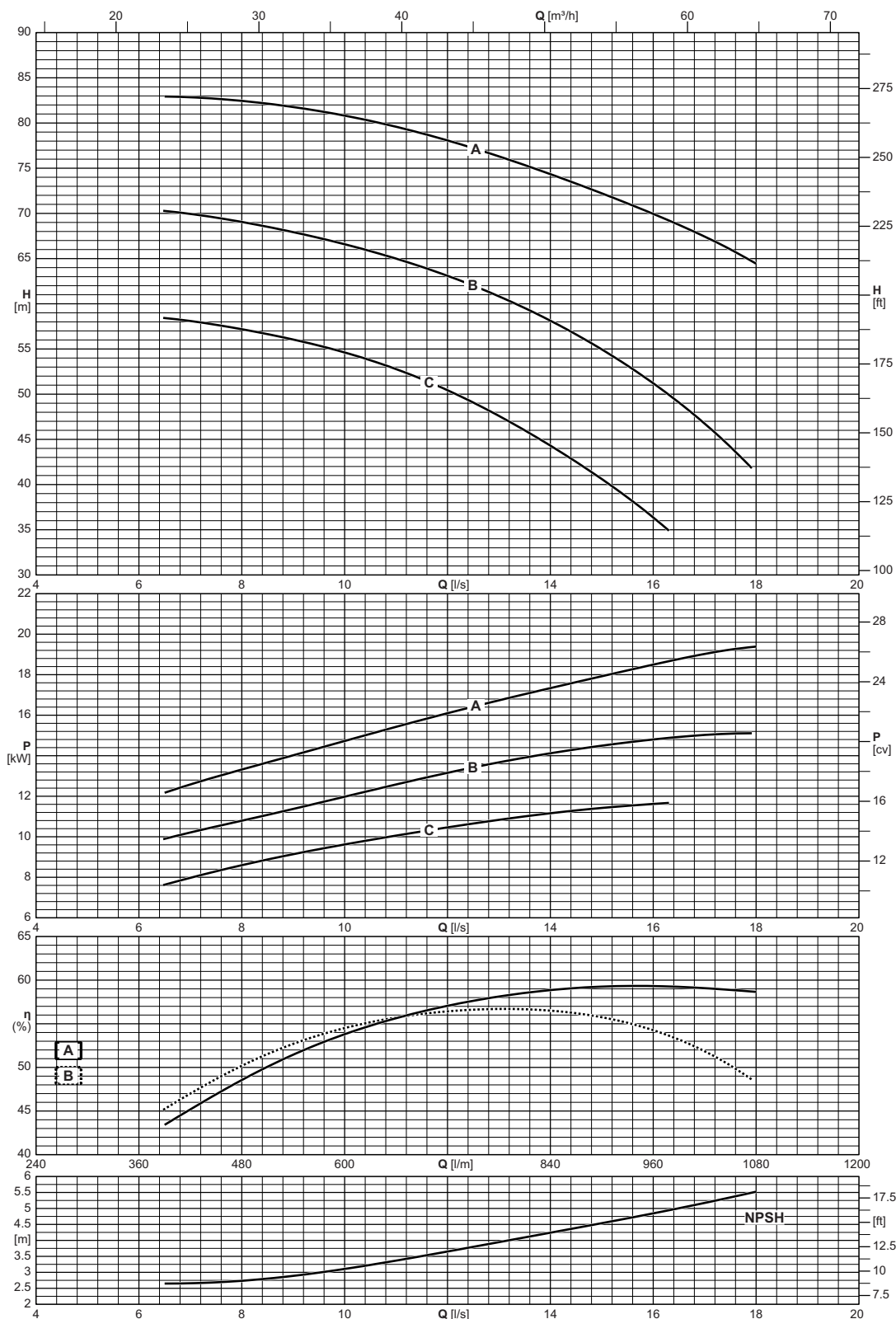

Type <i>Tun</i> Tipo	Inlet maximum pressure Макс. давление на всасывании Pressione massima in aspirazione [bar]
NCDS2P50-250	10

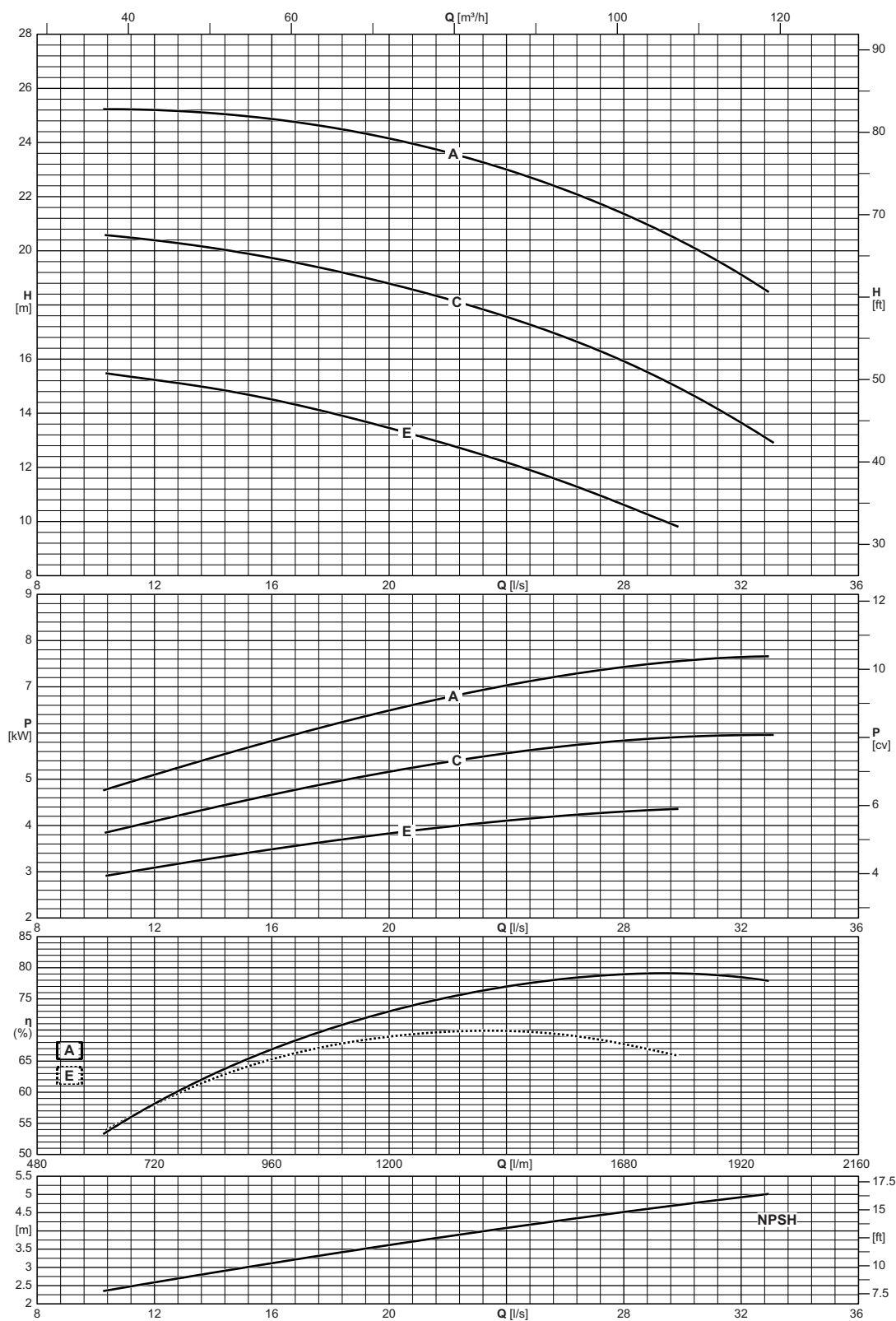

Type Тип Tipo	Inlet maximum pressure Макс. давление на всасывании Pressione massima in aspirazione
NCDS2P65-125	[bar] 16

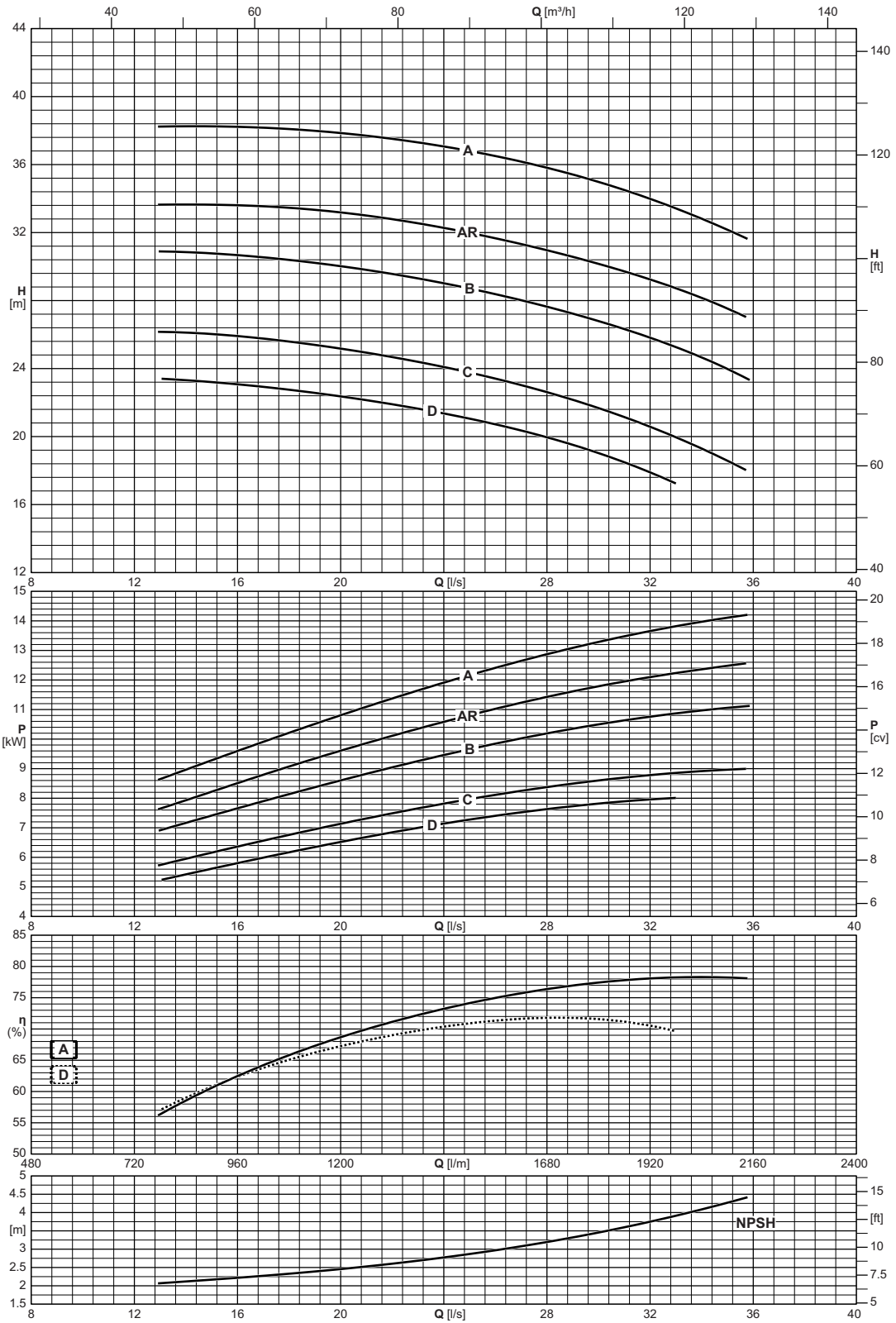

Type Тип Tipo	Inlet maximum pressure Макс. давление на всасывании Pressione massima in aspirazione
NCDS2P65-160	[bar] 16

Operating data
 Рабочие характеристики
 Caratteristiche di funzionamento

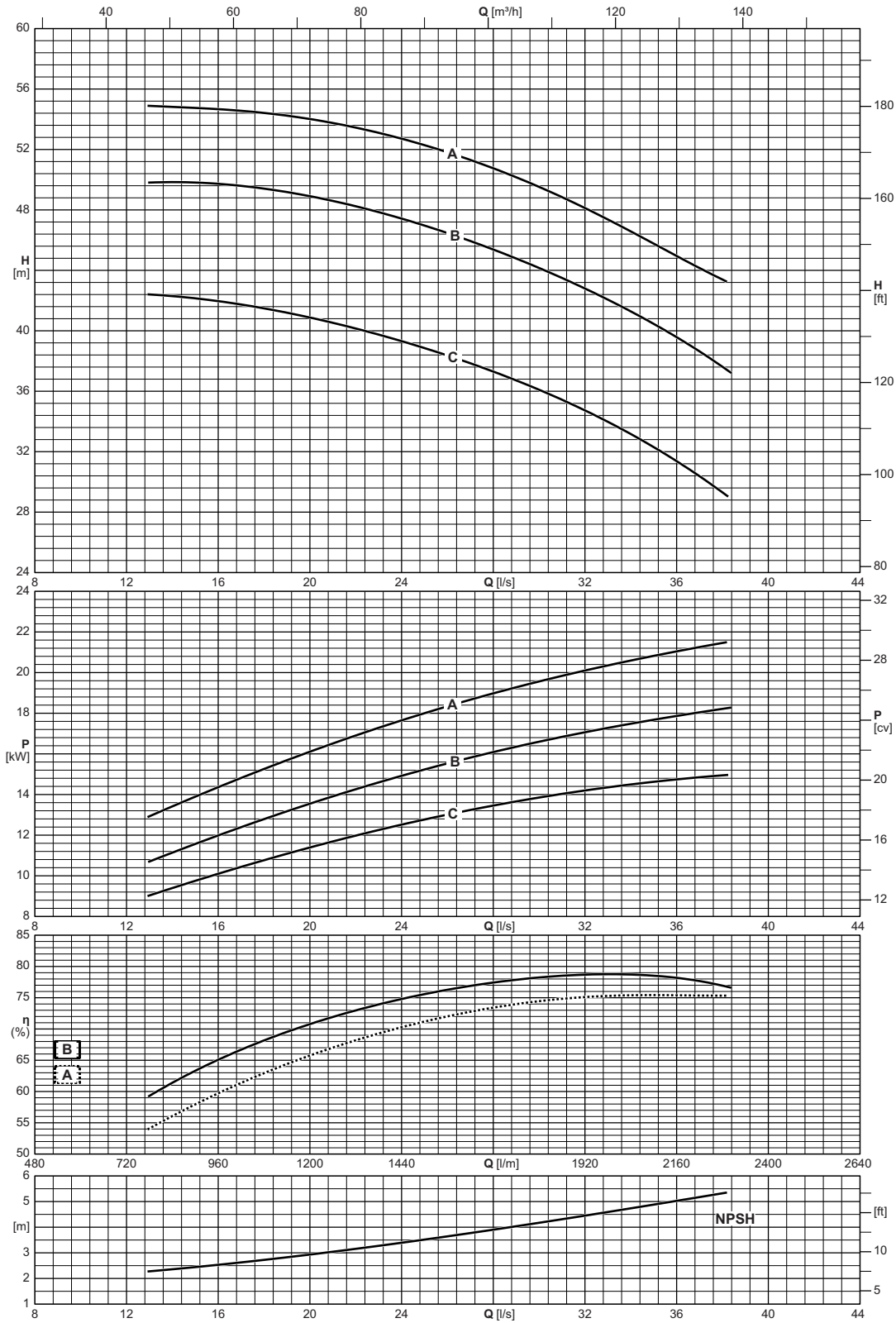

Type Тип Tipo	Inlet maximum pressure Макс. давление на всасывании Pressione massima in aspirazione
NCDS2P65-200	[bar] 16

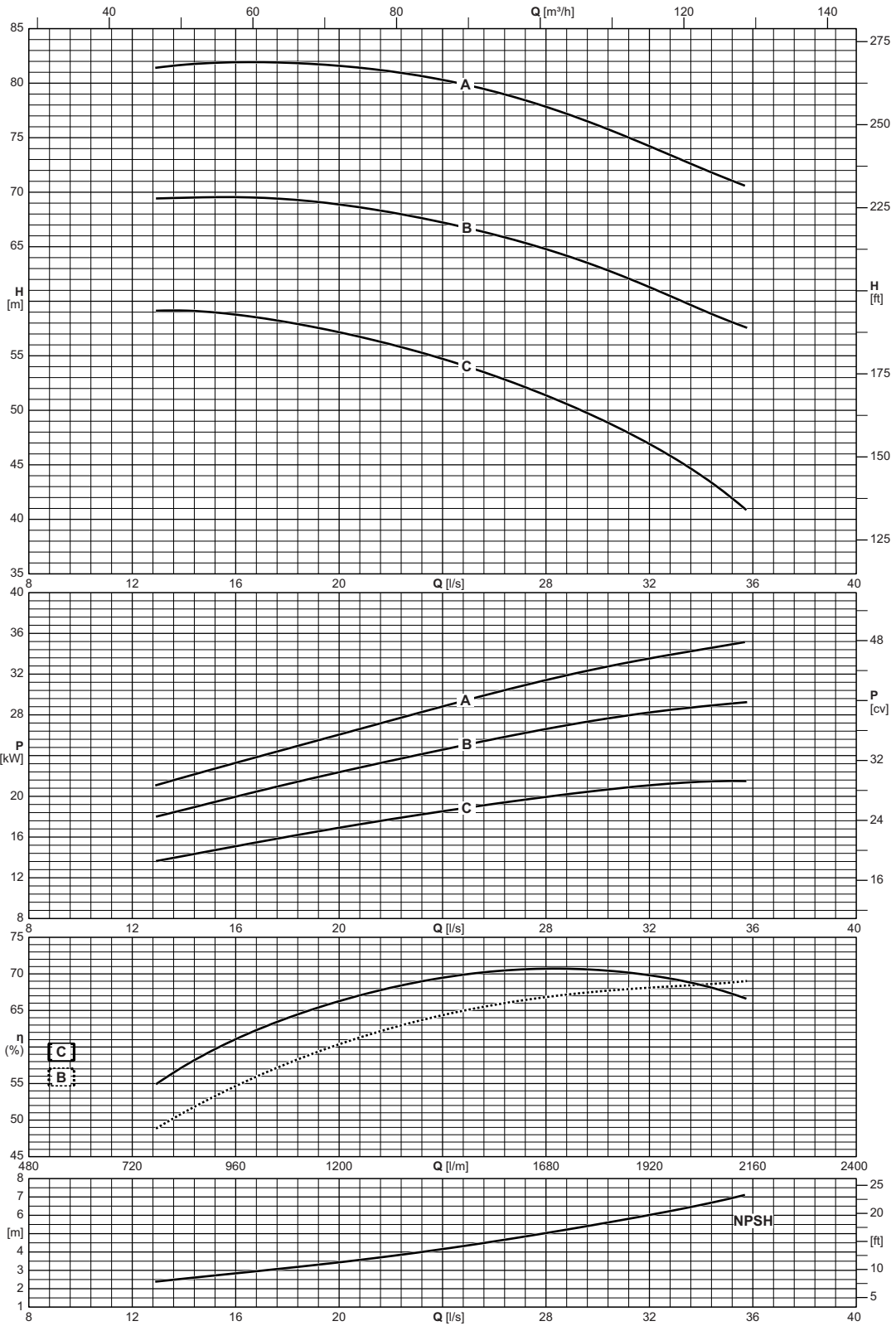

Type Тип Tipo	Inlet maximum pressure Макс. давление на всасывании Pressione massima in aspirazione [bar]
NCDS2P65-250	16

NCDS 2P80-160

3450 n [min⁻¹]

ErP Ready



Operating data
Рабочие характеристики
Caratteristiche di funzionamento

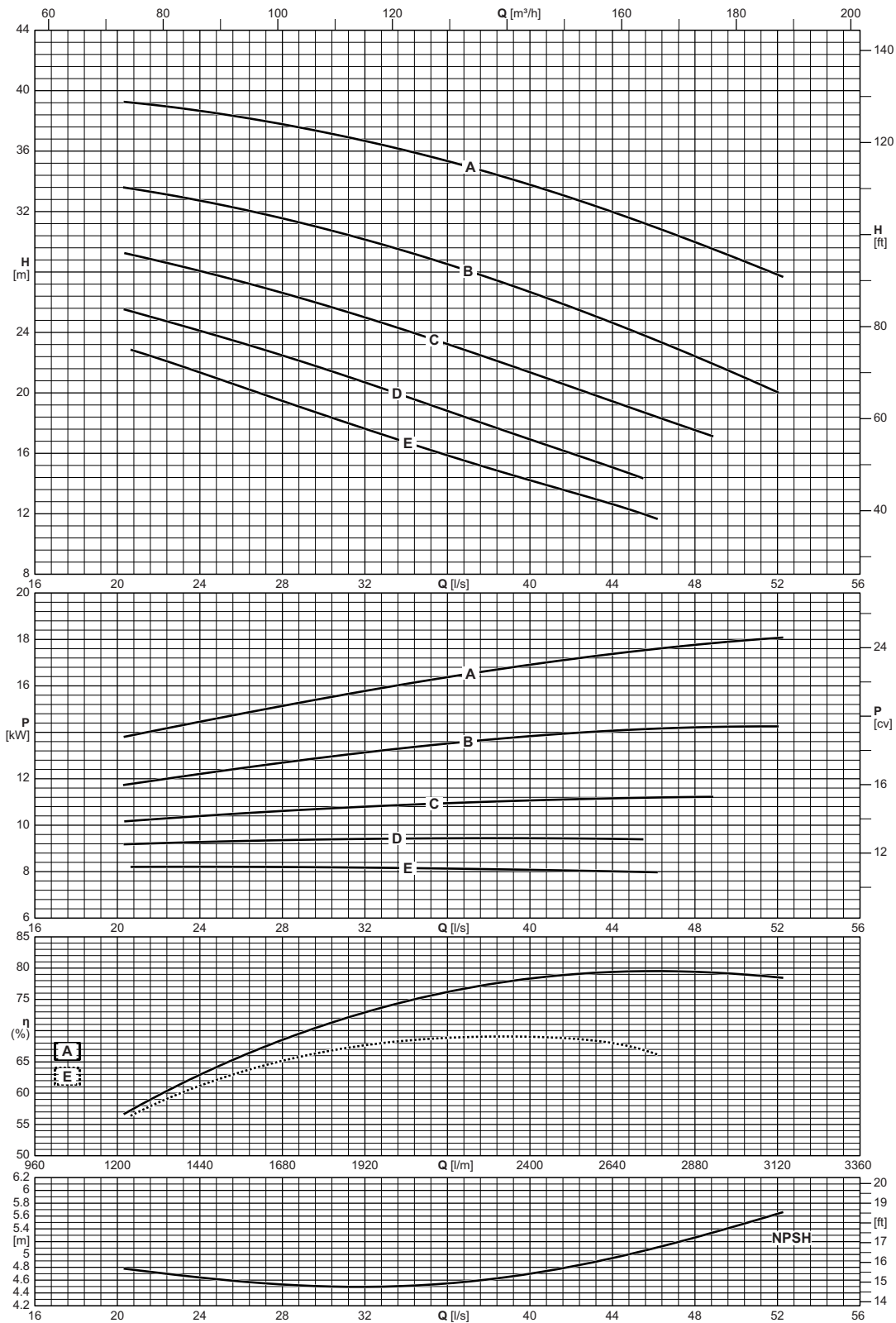

Type Тип Tipo	Inlet maximum pressure Макс. давление на всасывании Pressione massima in aspirazione
NCDS2P80-160	[bar] 16

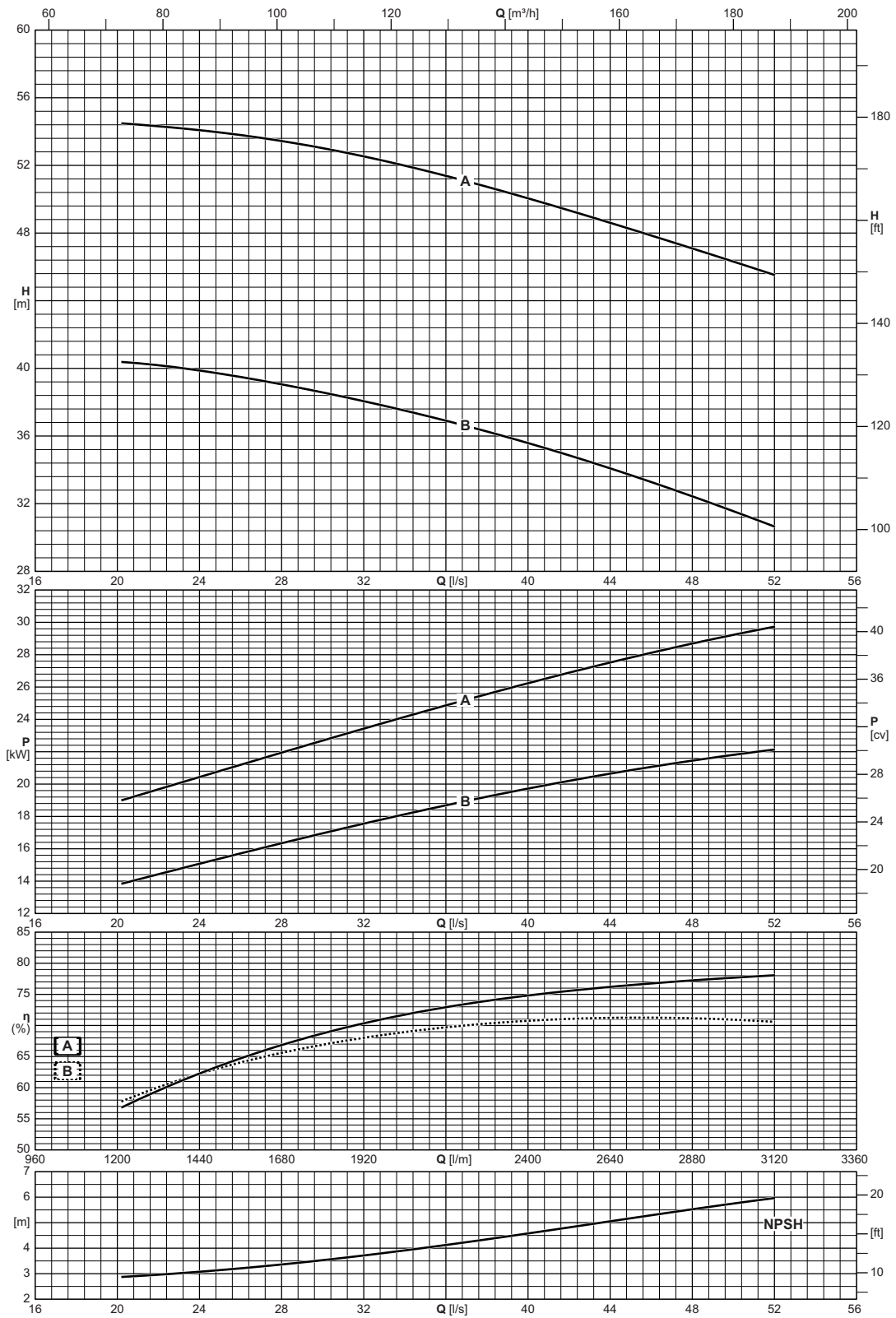

Type Typ Tipo	Inlet maximum pressure Макс. давление на всасывании Pressione massima in aspirazione
NCDS2P80-200	[bar] 10

NCDS 2P80-250

3450 n [min⁻¹]

ErP Ready



Operating data
Рабочие характеристики
Caratteristiche di funzionamento

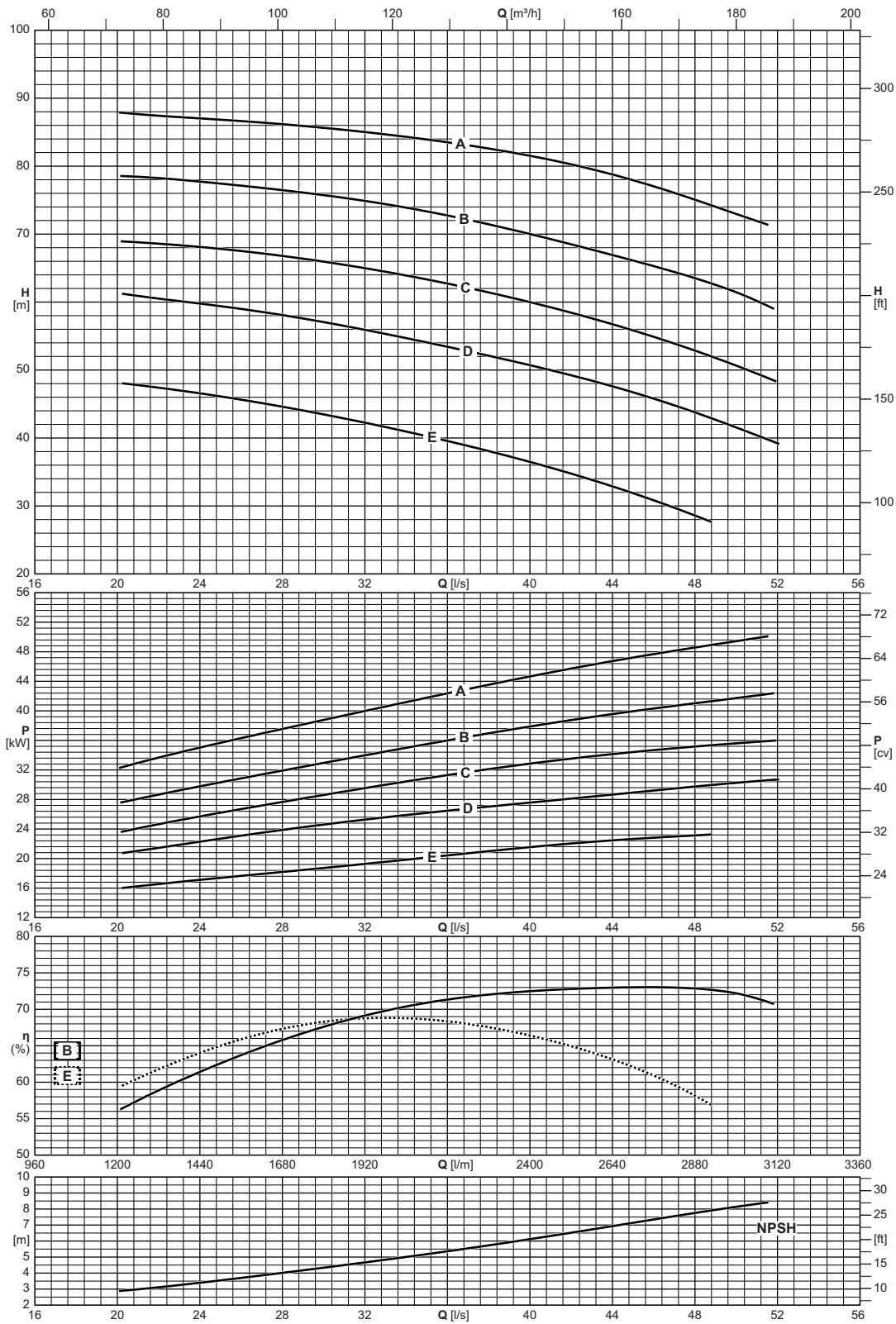

Type Тип Tipo	Inlet maximum pressure Макс. давление на всасывании Pressione massima in aspirazione
NCDS2P80-250	[bar] 16

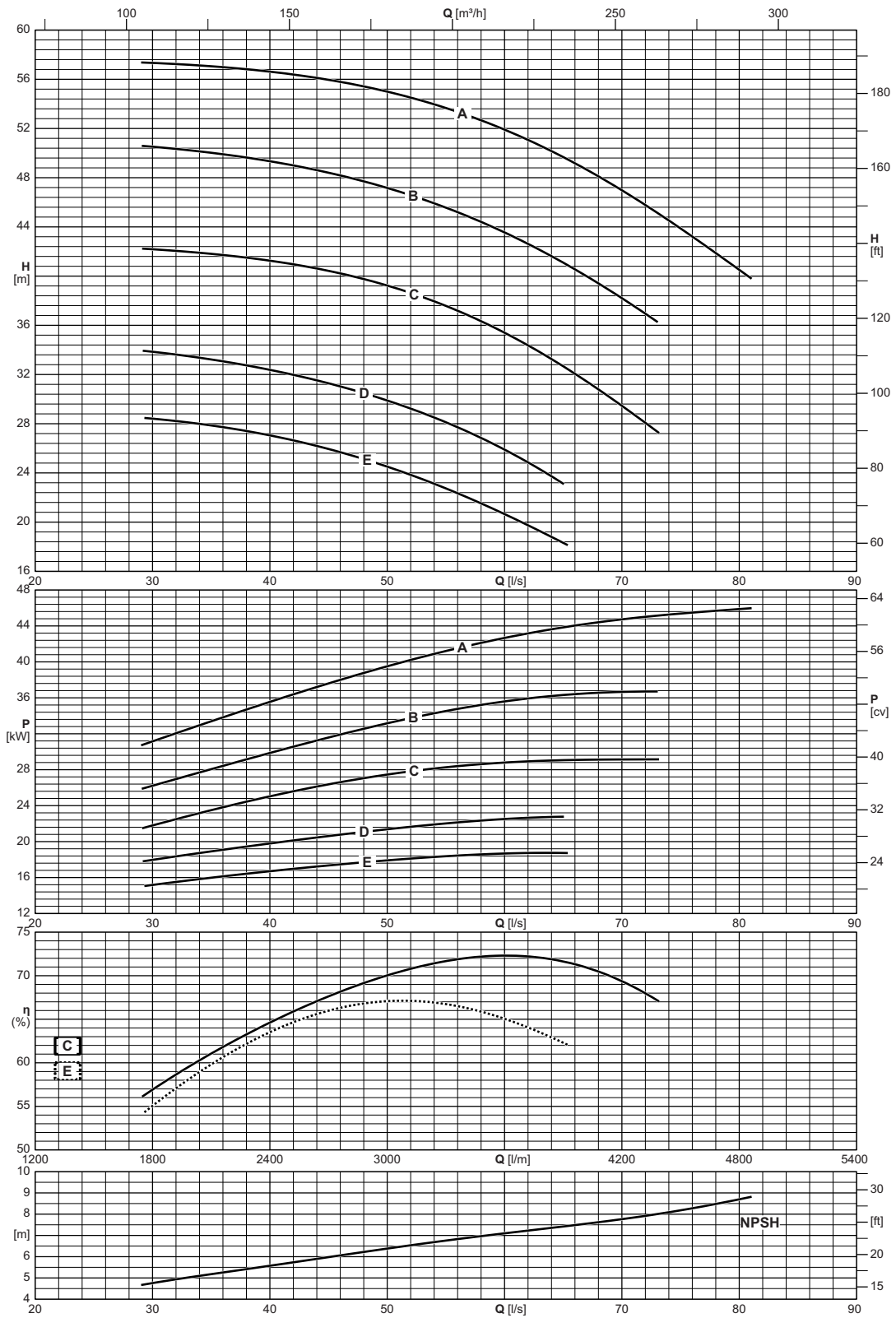

Type <i>Tun</i> Tipo	Inlet maximum pressure <i>Макс. давление на всасывании</i> Pressione massima in aspirazione
NCDS2P100-200	[bar] 16

NCDS 2P100-250

3450 n [min⁻¹]

ErP Ready



Operating data
Рабочие характеристики
Caratteristiche di funzionamento

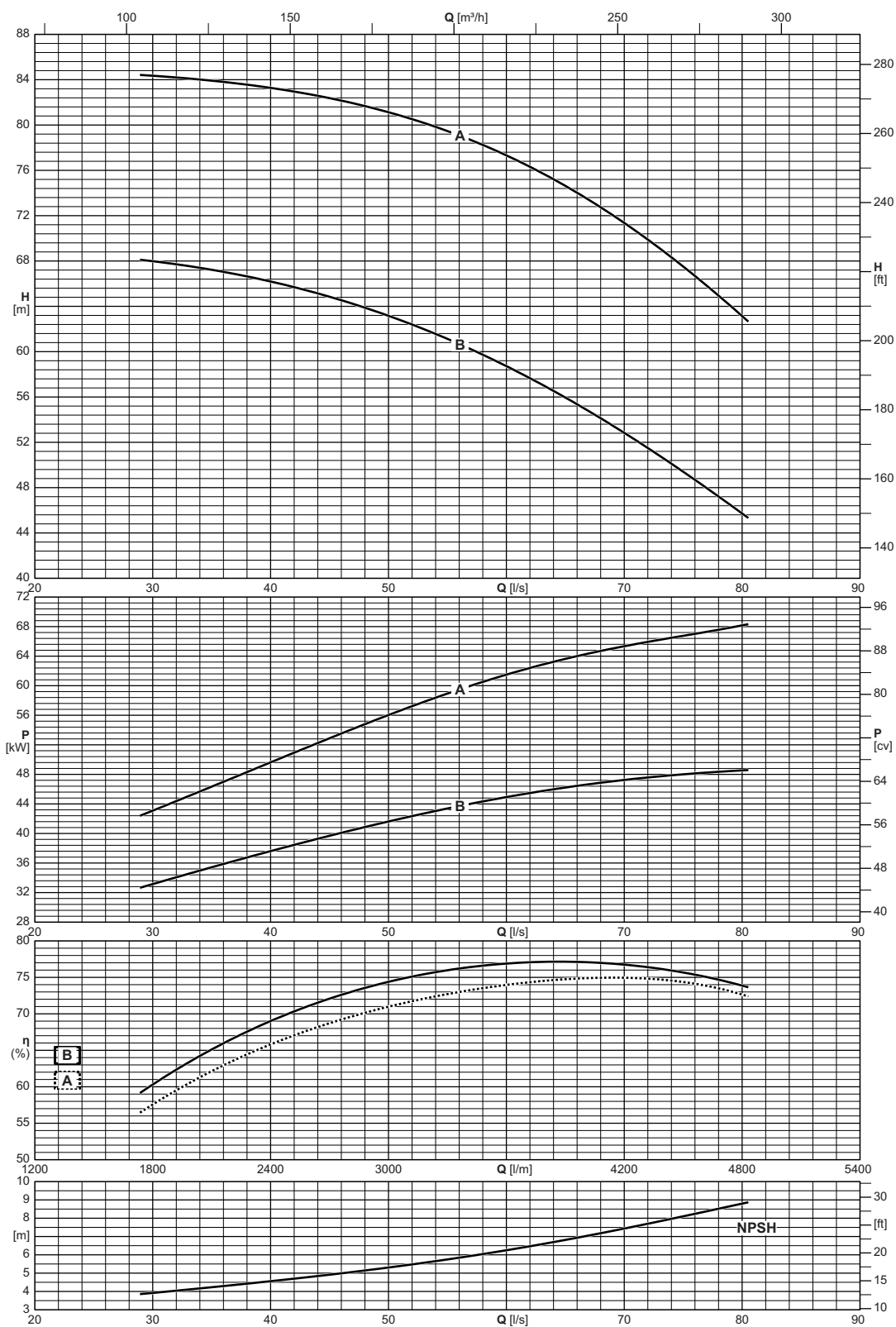

Type Тип Tipo	Inlet maximum pressure Макс. давление на всасывании Pressione massima in aspirazione
NCDS2P100-250	[bar] 10

Overall dimensions and weights
 Общие габариты и вес
 Dimensioni di ingombro e pesi

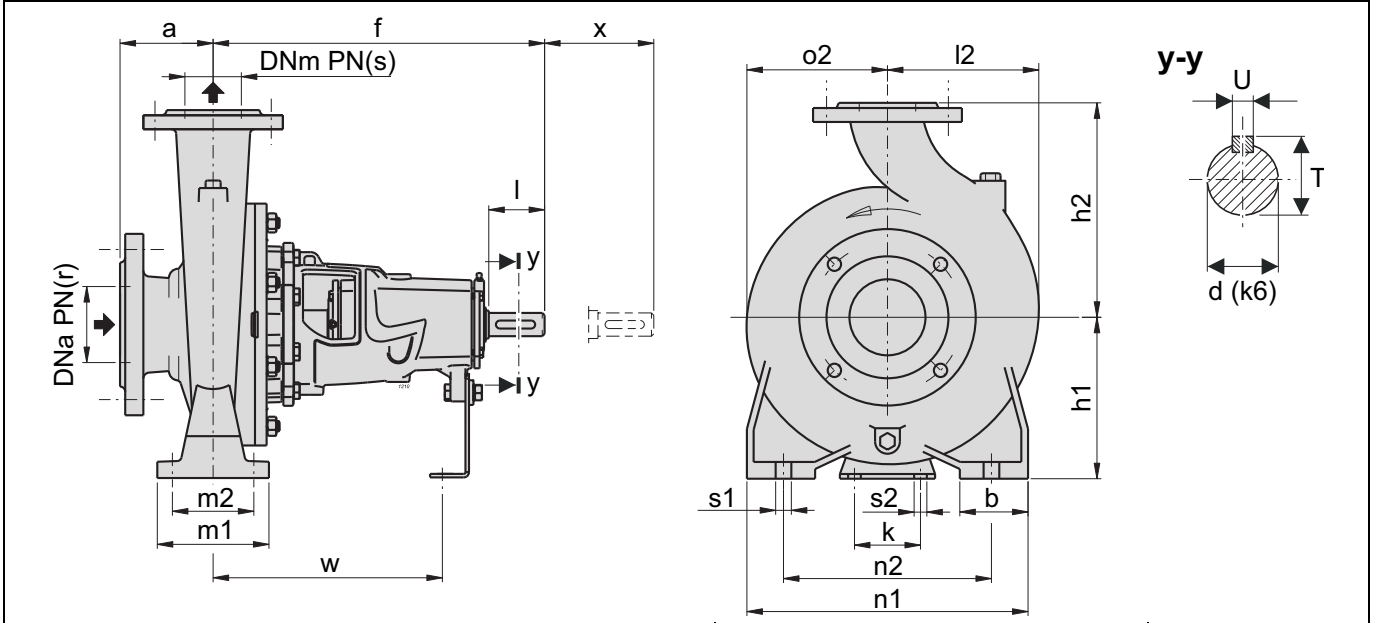

Type Tun Tipo	Weight Bec Peso [kg]	Dimensions pump Габариты насоса Dimensioni pompa											Duck foot pedestal dimensions Размеры опорных ножек Dimensioni piedi di appoggio								Shaft projection Выступ вала Sporgenza d'albero					
		DNa	DNm	r	s	a	f	h1	h2	l2	o2	b	m1	m2	n1	n2	k	w	s1	s2	d	l	T	U	x	
		[mm]																								
NCD(S)2P32-125	26	50	32	10-16	10-16	80	360	112	140	97	93	50	100	70	190	140	110	260	ø 14	ø 14	24	50	27	8	100	
NCD(S)2P32-160	33	50	32	10-16	10-16	80	360	132	160	120	120	50	100	70	240	190	110	260	ø 14	ø 14	24	50	27	8	100	
NCD(S)2P32L-160	31	50	32	10-16	10-16	80	360	132	160	120	120	50	100	70	240	190	110	260	ø 14	ø 14	24	50	27	8	100	
NCD(S)2P32L-200	40	50	32	10-16	10-16	80	360	160	180	140	140	50	100	70	240	190	110	260	ø 14	ø 14	24	50	27	8	100	
NCD(S)2P32-200	38	50	32	10-16	10-16	80	360	160	180	140	140	50	100	70	240	190	110	260	ø 14	ø 14	24	50	27	8	100	
NCD(S)2P40-125	28	65	40	10-16	10-16	80	360	112	140	113	100	50	100	70	210	160	110	260	ø 14	ø 14	24	50	27	8	100	
NCD(S)2P40-160	33	65	40	10-16	10-16	80	360	132	160	119	119	50	100	70	240	190	110	260	ø 14	ø 14	24	50	27	8	100	
NCD(S)2P40-200	40	65	40	10-16	10-16	100	360	160	180	140	140	50	100	70	265	212	110	260	ø 14	ø 14	24	50	27	8	100	
NCD(S)2P40-250	55	65	40	10-16	10-16	100	360	180	225	175	175	65	125	95	320	250	110	260	ø 14	ø 14	24	50	27	8	100	
NCD(S)2P50-125	34	65	50	10-16	10-16	100	360	132	160	137	121	50	100	70	240	190	110	260	ø 14	ø 14	24	50	27	8	100	
NCD(S)2P50-160	33	65	50	10-16	10-16	100	360	160	180	141	127	50	100	70	265	212	110	260	ø 14	ø 14	24	50	27	8	100	
NCD(S)2P50-200	44	65	50	10-16	10-16	100	360	160	200	153	140	50	100	70	265	212	110	260	ø 14	ø 14	24	50	27	8	100	
NCD(S)2P50-250	57	65	50	10-16	10-16	100	360	180	225	175	175	65	125	95	320	250	110	260	ø 14	ø 14	24	50	27	8	100	
NCD(S)2P65-125	38	80	65	10-16	10-16	100	360	160	180	155	134	65	125	95	280	212	110	260	ø 14	ø 14	24	50	27	8	100	
NCD(S)2P65-160	40	80	65	10-16	10-16	100	360	160	200	172	150	65	125	95	280	212	110	260	ø 14	ø 14	24	50	27	8	100	
NCD(S)2P65-200	48	80	65	10-16	10-16	100	360	180	225	175	155	65	125	95	320	250	110	260	ø 14	ø 14	24	50	27	8	140	
NCD(S)2P65-250	88	80	65	10-16	10-16	100	470	200	250	190	175	80	160	120	360	280	110	340	ø 18	ø 14	32	80	35	10	140	
NCD(S)2P80-160	48	100	80	10-16	10-16	125	360	180	225	193	165	65	125	95	320	250	110	260	ø 14	ø 14	24	50	27	8	140	
NCD(S)2P80-200	80	100	80	10-16	10-16	125	470	180	250	194	170	65	125	95	345	280	110	340	ø 14	ø 14	32	80	35	10	140	
NCD(S)2P80-250	92	100	80	10-16	10-16	125	470	200	280	210	191	80	160	120	400	315	110	340	ø 18	ø 14	32	80	35	10	140	
NCD(S)2P100-200	83	125	100	10-16	10-16	125	470	200	280	212	180	80	160	120	360	280	110	340	ø 18	ø 14	32	80	35	10	140	
NCD(S)2P100-250	103	125	100	10-16	10-16	140	470	225	280	233	205	80	160	120	400	315	110	340	ø 18	ø 14	32	80	35	10	140	
NCD(S)4P32-125	25	50	32	10-16	10-16	80	360	112	140	97	93	50	100	70	190	140	110	260	ø 14	ø 14	24	50	27	8	100	
NCD(S)4P32-160	33	50	32	10-16	10-16	80	360	132	160	120	120	50	100	70	240	190	110	260	ø 14	ø 14	24	50	27	8	100	
NCD(S)4P32-200	37	50	32	10-16	10-16	80	360	160	180	140	140	50	100	70	240	190	110	260	ø 14	ø 14	24	50	27	8	100	
NCD(S)4P40-160	33	65	40	10-16	10-16	80	360	132	160	119	119	50	100	70	240	190	110	260	ø 14	ø 14	24	50	27	8	100	
NCD(S)4P40-200	40	65	40	10-16	10-16	100	360	160	180	140	140	50	100	70	265	212	110	260	ø 14	ø 14	24	50	27	8	100	
NCD(S)4P40-250	55	65	40	10-16	10-16	100	360	180	225	175	175	65	125	95	320	250	110	260	ø 14	ø 14	24	50	27	8	100	
NCD(S)4P50-125	34	65	50	10-16	10-16	100	360	132	160	137	121	50	100	70	240	190	110	260	ø 14	ø 14	24	50	27	8	100	
NCD(S)4P50-160	33	65	50	10-16	10-16	100	360	160	180	141	127	50	100	70	265	212	110	260	ø 14	ø 14	24	50	27	8	100	
NCD(S)4P50-200	44	65	50	10-16	10-16	100	360	160	200	153	140	50	100	70	265	212	110	260	ø 14	ø 14	24	50	27	8	100	
NCD(S)4P50-250	57	65	50	10-16	10-16	100	360	180	225	175	175	65	125	95	320	250	110	260	ø 14	ø 14	24	50	27	8	100	
NCD(S)4P65-125	38	80	65	10-16	10-16	100	360	160	180	155	134	65	125	95	280	212	110	260	ø 14	ø 14	24	50	27	8	100	
NCD(S)4P65-160	40	80	65	10-16	10-16	100	360	160	200	172	150	65	125	95	280	212	110	260	ø 14	ø 14	24	50	27	8	100	
NCD(S)4P65-200	48	80	65	10-16	10-16	100	360	180	225	175	155	65	125	95	320	250	110	260	ø 14	ø 14	24	50	27	8	140	
NCD(S)4P65-250	89	80	65	10-16	10-16	100	470	200	250	190	175	80	160	120	360	280	110	340	ø 18	ø 14	32	80	35	10	140	
NCD(S)4P65-315	131	80	65	10-16	10-16	125	470	225	280	220	220	80	160	120	400	315	110	340	ø 18	ø 14	32	80	35	10	140	
NCD(S)4P80-160	48	100	80	10-16	10-16	125	360	180	225	193	165	65	125	95	320	250	110	260	ø 14	ø 14	24	50	27	8	140	
NCD(S)4P80-200	80	100	80	10-16	10-16	125	470	180	250	194	170	65	125	95	345	280	110	340	ø 14	ø 14	32	80	35	10	140	
NCD(S)4P80-250	92	100	80	10-16	10-16	125	470	200	280	210	191	80	160	120	400	315	110	340	ø 18	ø 14	32	80	35	10	140	
NCD(S)4P80-315	128	100	80	10-16	10-16	125	470	250	315	232	220	80	160	120	400	315	110	340	ø 18	ø 14	32	80	35	10	140	
NCD(S)4P80-400	184	100	80	10-16	10-16	125	530	280	355	268	268	80	160	120	435	355	110	370	ø 18	ø 14	42	110	45	12	140	
NCD(S)4P100-200	83	125	100	10-16	10-16	125	470	200	280	212	180	80	160	120	360	280	110	340	ø 18	ø 14	32	80	35	10	140	
NCD(S)4P100-250	103	125	100	10-16	10-16	140	470	225	280	233	205	80	160	120	400	315	110	340	ø 18	ø 14	32	80	35	10	140	
NCD(S)4P100-315	138	125	100	10-16	10-16	140	470	250	315	250	230	80	160	120	400	315	110	340	ø 18	ø 14	32	80	35	10	140	

Overall dimensions and weights
 Общие габариты и вес
 Dimensioni di ingombro e pesi

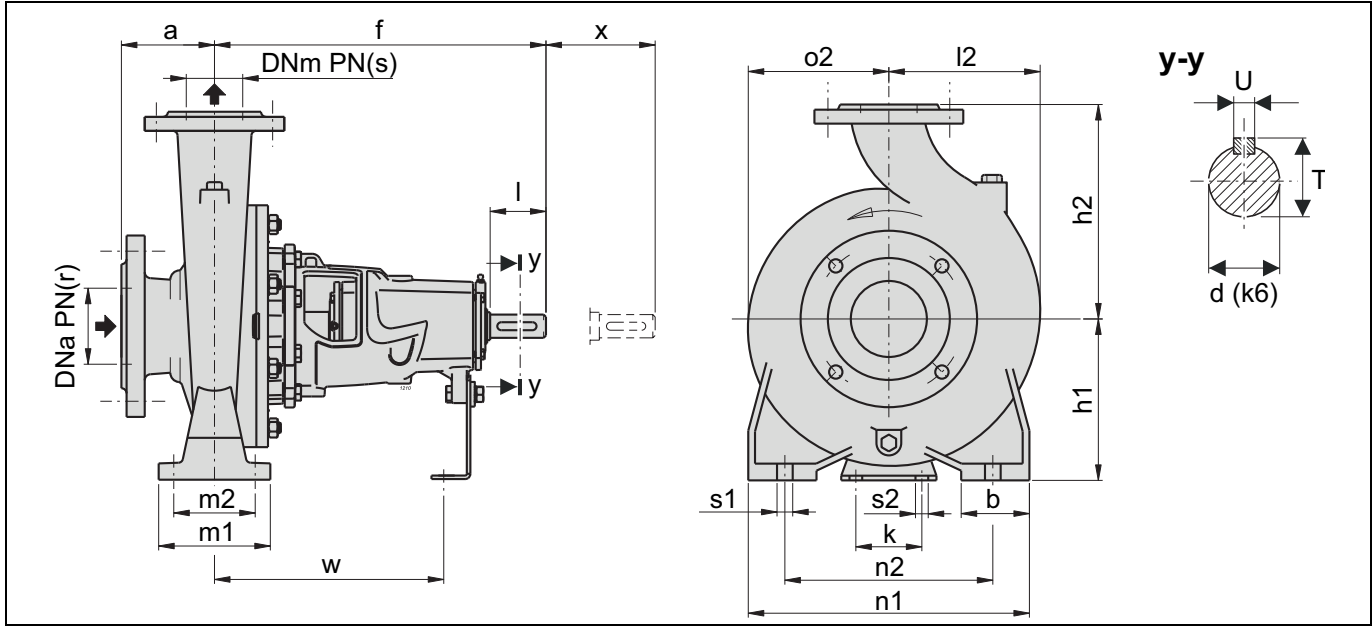

Type Тип Tipo	Weight Вес Peso [kg]	Dimensions pump Габариты насоса Dimensioni pompa										Duck foot pedestal dimensions Размеры опорных ножек Dimensioni piedi di appoggio								Shaft projection Выступ вала Sporgenza d'albero					
		DNa	DNm	r	s	a	f	h1	h2	l2	o2	b	m1	m2	n1	n2	k	w	s1	s2	d	l	T	U	x
		[mm]																							
NCD(S)4P100-400	199	125	100	10-16	10-16	140	530	280	355	280	268	100	200	150	500	400	110	370	∅ 22	∅ 14	42	110	45	12	140
NCD(S)4P125-250	125	150	125	10-16	10-16	140	470	250	355	268	235	80	160	120	400	315	110	340	∅ 18	∅ 14	32	80	35	10	140
NCD(S)4P125-315	189	150	125	10-16	10-16	140	530	280	355	278	247	100	200	150	500	400	110	370	∅ 22	∅ 14	42	110	45	12	140
NCD(S)4P125-400	221	150	125	10-16	10-16	140	530	315	400	305	280	100	200	150	500	400	110	370	∅ 22	∅ 14	42	110	45	12	140
NCD(S)4P150-315	200	200	150	10	10-16	160	530	280	400	298	260	100	200	150	550	450	110	370	∅ 22	∅ 14	42	110	45	12	140
NCD(S)4P150-400	246	200	150	10	10-16	160	530	315	450	328	295	100	200	150	550	450	110	370	∅ 22	∅ 14	42	110	45	12	140
NCD(S)4P200-315	327	250	200	16	16	180	630	355	450	370	322	125	250	190	630	500	110	463	∅ 27	∅ 14	55	110	59	16	200
NCD(S)4P200-400	350	250	200	16	16	180	630	355	500	370	322	125	250	190	630	500	110	463	∅ 27	∅ 14	55	110	59	16	200

Selection - dimensions and weights for base mounted electric pumps
 Подбор - габариты и вес электронасосов на раме
 Selezione - dimensioni e pesi elettropompe su base

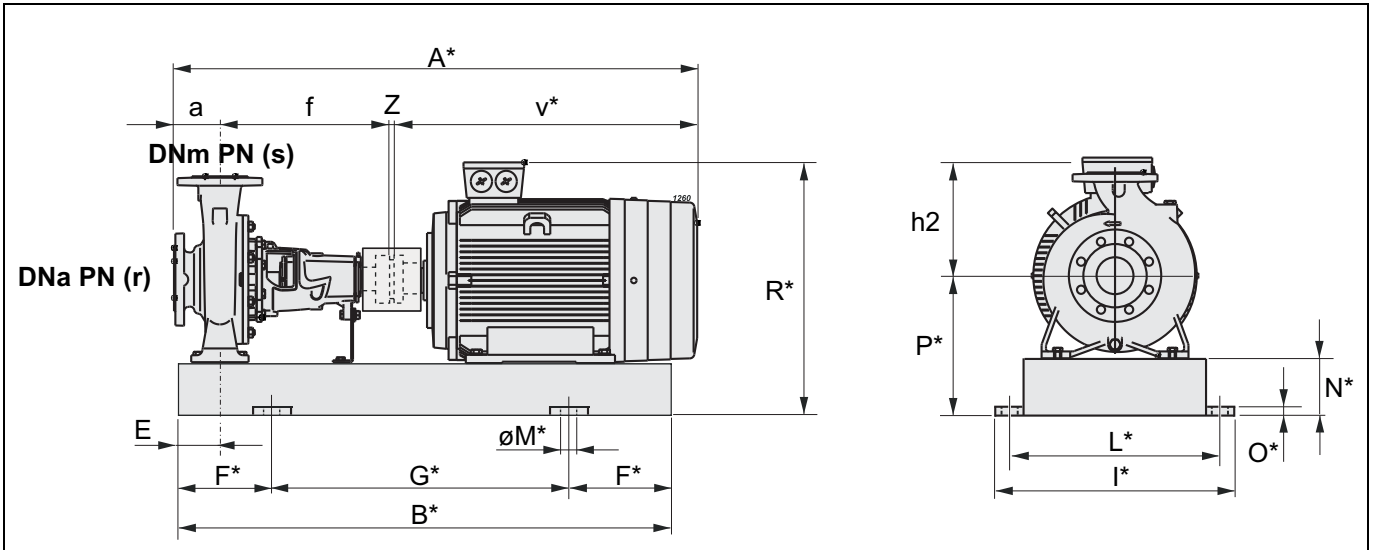

Pump Насос Pompa		Motor Двигатель Motore		Weight Вес Peso	BGAD	A	B	E	F	G	I	L	M	N	O	P	R	V	Z	a	f	h2	r	s	
Type Тип	DNa DNm [mm]	[kW]	Size Размер Grand.	[kg]	Type Тип	[mm]																			
NCD2P32-125	50 32	1,1	80	52	1002	739	649	60	100	449	320	270	ø 16	50	38	162	287	295	4	80	360	140	10-16	10-16	
NCD2P32-125	50 32	1,5	90S	56	1003	799	665	60	100	465	320	270	ø 16	50	38	162	300	355	4	80	360	140	10-16	10-16	
NCD2P32-160	50 32	2,2	90L	72	1004	829	690	60	100	490	370	320	ø 16	65	38	197	335	385	4	80	360	160	10-16	10-16	
NCD2P32-160	50 32	3	100L	107	1006	849	724,5	60	100	524,5	370	320	ø 16	65	38	197	347	405	4	80	360	160	10-16	10-16	
NCD2P32L-160	50 32	4	112M	85	1007	884	732	60	100	532	370	320	ø 16	65	38	197	369	440	4	80	360	160	10-16	10-16	
NCD2P32-200	50 32	4	112M	91	1012	884	742	60	100	542	370	320	ø 16	80	38	240	412	440	4	80	360	180	10-16	10-16	
NCD2P32-200	50 32	5,5	132S	105	1013	899	773	60	150	473	405	355	ø 16	80	38	240	432	455	4	80	360	180	10-16	10-16	
NCD2P32L-200	50 32	7,5	132S	112	1013	899	773	60	150	473	405	355	ø 16	80	38	240	432	455	4	80	360	180	10-16	10-16	
NCD2P40-125	65 40	2,2	90L	62	1005	829	690	60	100	490	340	290	ø 16	50	38	162	300	385	4	80	360	140	10-16	10-16	
NCD2P40-160	65 40	4	112M	87	1007	884	732	60	100	532	370	320	ø 16	65	38	197	369	440	4	80	360	160	10-16	10-16	
NCD2P40-160	65 40	5,5	132S	96	1017	899	773	60	150	473	405	355	ø 16	65	38	197	389	455	4	80	360	160	10-16	10-16	
NCD2P40-200	65 40	7,5	132S	121	1019	919	773	60	150	473	395	345	ø 16	80	38	240	432	455	4	100	360	180	10-16	10-16	
NCD2P40-250	65 40	15	160M	246	1021	1091	909,5	72,5	150	609,5	450	400	ø 20	100	42	280	531	627	4	100	360	225	10-16	10-16	
NCD2P50-125	65 50	4	112M	88	1007	904	732	60	100	532	370	320	ø 16	65	38	197	369	440	4	100	360	160	10-16	10-16	
NCD2P50-160	65 50	7,5	132S	115	1019	919	773	60	150	473	395	345	ø 16	80	38	240	432	455	4	100	360	180	10-16	10-16	
NCD2P50-200	65 50	11	160M	209	1024	1091	897	60	150	597	465	415	ø 16	80	38	240	491	627	4	100	360	200	10-16	10-16	
NCD2P50-250	65 50	18,5	160L	250	1062	1091	953,5	72,5	150	653,5	450	400	ø 20	100	42	280	531	627	4	100	360	225	10-16	10-16	
NCD2P65-125	80 65	7,5	132S	105	1066	919	785,5	72,5	150	485,5	410	360	ø 16	80	38	240	432	455	4	100	360	180	10-16	10-16	
NCD2P65-160	80 65	15	160M	199	1070	1091	909,5	72,5	150	609,5	465	415	ø 16	80	38	240	491	627	4	100	360	200	10-16	10-16	
NCD2P65-200	80 65	22	180M	292	1026	1129	963,5	72,5	150	663,5	500	450	ø 20	100	42	280	550	665	4	100	360	225	10-16	10-16	
NCD2P65-250	80 65	37	200L	427	1029	1312	1164	90	200	764	540	490	ø 20	100	42	300	600	738	4	100	470	250	10-16	10-16	
NCD2P80-160	100 80	18,5	160L	241	1062	1116	953,5	72,5	150	653,5	450	400	ø 20	100	42	280	531	627	4	125	360	225	10-16	10-16	
NCD2P80-200	100 80	30	200L	367	1038	1337	1171,5	97,5	200	771,5	540	490	ø 20	100	42	300	600	738	4	125	470	250	10-16	10-16	
NCD2P80-250	100 80	55	250M	566	1042	1469	1312	120	200	912	635	585	ø 20	120	42	370	745	870	4	125	470	280	10-16	10-16	
NCD2P100-200	125 100	45	225M	512	1050	1374	1220	120	200	820	585	535	ø 20	120	42	345	675	775	4	125	470	280	10-16	10-16	
NCD2P100-250	125 100	75	280S	773	1052	1614	1379	130	250	879	695	645	ø 20	140	42	420	815	1000	4	140	470	280	10-16	10-16	

BGAD = Base and coupling
 * = Indicatives values according to the type of motor installed.

BGAD = Рама и муфта
 * = Приблизит. значения в завис. от марки двигателя.

BGAD = Base e giunto
 * = Valori indicativi in funzione della marca di motore utilizzato.

o Motor in IE4 efficiency class according to EU REGULATION 2019/1781. Available in other efficiency classes for non-EU markets.

o Двигатель класса эффективности IE4 в соответствии с РЕГЛАМЕНТОМ UE2019/1781. Имеются варианты других классов эффективности для рынков за пределами ЕС.

o Motore in classe di efficienza IE4 in conformità al REGOLAMENTO UE2019/1781. Disponibili in altre classi di efficienza per mercati extra UE.

Selection - dimensions and weights for base mounted electric pumps
 Подбор - габариты и вес электронасосов на раме
 Selezione - dimensioni e pesi elettropompe su base

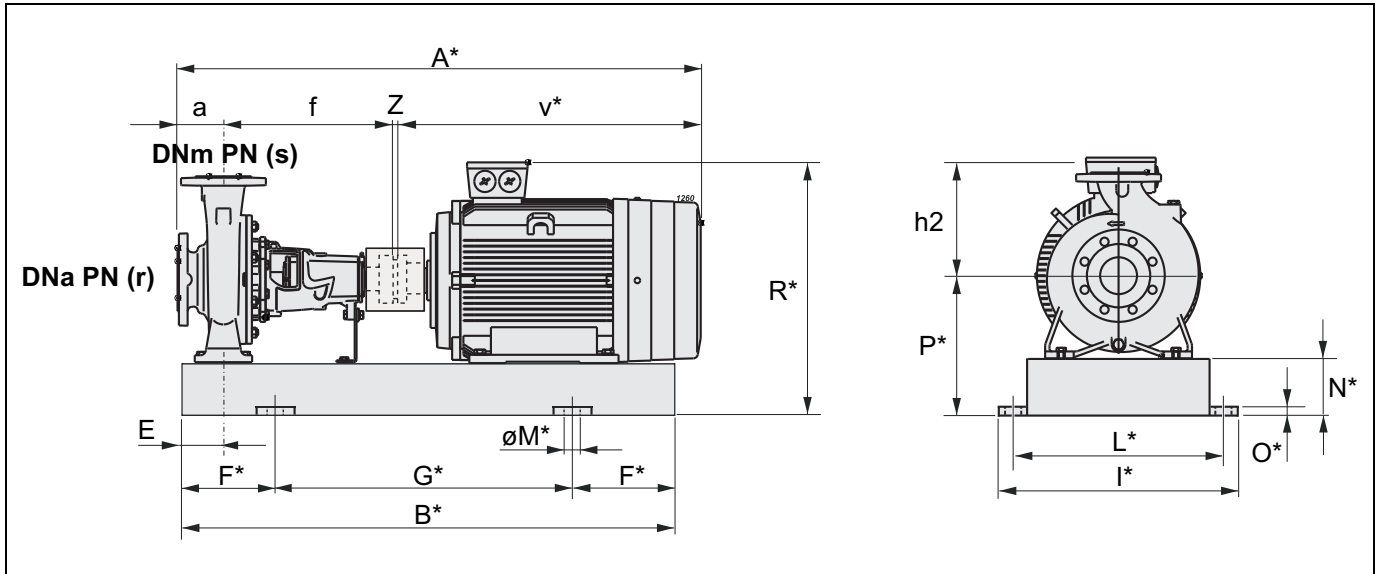

Pump Насос Pompa		Motor Двигатель Motore		Weight Вес Peso	BGAD	A*	B*	E	F*	G*	I*	L*	M*	N*	O*	P*	R*	V*	Z	a	f	h2	r	s		
Type Тип Tipo	DNa [mm]	DNm [mm]	[kW]	Size Размер Grand.	[kg]	Type Тип Tipo	[mm]																			
NCDS2P32-125	50	32	1,1	80	52	1002	739	649	60	100	449	320	270	Ø 16	50	38	162	287	295	4	80	360	140	10-16	10-16	
NCDS2P32-125	50	32	1,5	90S	56	1003	799	665	60	100	465	320	270	Ø 16	50	38	162	300	355	4	80	360	140	10-16	10-16	
NCDS2P32-160	50	32	2,2	90L	72	1004	829	690	60	100	490	370	320	Ø 16	65	38	197	335	385	4	80	360	160	10-16	10-16	
NCDS2P32-160	50	32	3	100L	107	1006	849	724,5	60	100	524,5	370	320	Ø 16	65	38	197	347	405	4	80	360	160	10-16	10-16	
NCDS2P32L-160	50	32	4	112M	85	1007	884	732	60	100	532	370	320	Ø 16	65	38	197	369	440	4	80	360	160	10-16	10-16	
NCDS2P32-200	50	32	4	112M	91	1012	884	742	60	100	542	370	320	Ø 16	80	38	240	412	440	4	80	360	180	10-16	10-16	
NCDS2P32-200	50	32	5,5	132S	104	1013	899	773	60	150	473	405	355	Ø 16	80	38	240	432	455	4	80	360	180	10-16	10-16	
NCDS2P32L-200	50	32	7,5	132S	112	1013	899	773	60	150	473	405	355	Ø 16	80	38	240	432	455	4	80	360	180	10-16	10-16	
NCDS2P40-125	65	40	2,2	90L	61	1005	829	690	60	100	490	340	290	Ø 16	50	38	162	300	385	4	80	360	140	10-16	10-16	
NCDS2P40-160	65	40	4	112M	86	1007	884	732	60	100	532	370	320	Ø 16	65	38	197	369	440	4	80	360	160	10-16	10-16	
NCDS2P40-160	65	40	5,5	132S	96	1017	899	773	60	150	473	405	355	Ø 16	65	38	197	389	455	4	80	360	160	10-16	10-16	
NCDS2P40-200	65	40	7,5	132S	121	1019	919	773	60	150	473	395	345	Ø 16	80	38	240	432	455	4	100	360	180	10-16	10-16	
NCDS2P40-250	65	40	15	160M	244	1021	1091	909,5	72,5	150	609,5	450	400	Ø 20	100	42	280	531	627	4	100	360	225	10-16	10-16	
NCDS2P50-125	65	50	4	112M	88	1007	904	732	60	100	532	370	320	Ø 16	65	38	197	369	440	4	100	360	160	10-16	10-16	
NCDS2P50-125	65	50	5,5	132S	98	1017	919	773	60	150	473	405	355	Ø 16	65	38	197	389	455	4	100	360	160	10-16	10-16	
NCDS2P50-160	65	50	7,5	132S	115	1019	919	773	60	150	473	395	345	Ø 16	80	38	240	432	455	4	100	360	180	10-16	10-16	
NCDS2P50-200	65	50	11	160M	208	1024	1091	897	60	150	597	465	415	Ø 16	80	38	240	491	627	4	100	360	200	10-16	10-16	
NCDS2P50-250	65	50	18,5	160L	249	1062	1091	953,5	72,5	150	653,5	450	400	Ø 20	100	42	280	531	627	4	100	360	225	10-16	10-16	
NCDS2P65-125	80	65	7,5	132S	105	1066	919	785,5	72,5	150	485,5	410	360	Ø 16	80	38	240	432	455	4	100	360	180	10-16	10-16	
NCDS2P65-160	80	65	15	160M	198	1070	1091	909,5	72,5	150	609,5	465	415	Ø 16	80	38	240	491	627	4	100	360	200	10-16	10-16	
NCDS2P65-200	80	65	22	180M	291	1026	1129	963,5	72,5	150	663,5	500	450	Ø 20	100	42	280	550	665	4	100	360	225	10-16	10-16	
NCDS2P65-250	80	65	37	200L	426	1029	1312	1164	90	200	764	540	490	Ø 20	100	42	300	600	738	4	100	470	250	10-16	10-16	
NCDS2P80-160	100	80	18,5	160L	241	1062	1116	953,5	72,5	150	653,5	450	400	Ø 20	100	42	280	531	627	4	125	360	225	10-16	10-16	
NCDS2P80-200	100	80	30	200L	367	1038	1337	1171,5	97,5	200	771,5	540	490	Ø 20	100	42	300	600	738	4	125	470	250	10-16	10-16	
NCDS2P80-250	100	80	55	250M	565	1042	1469	1312	120	200	912	635	585	Ø 20	120	42	370	745	870	4	125	470	280	10-16	10-16	
NCDS2P100-200	125	100	45	225M	511	1050	1374	1220	120	200	820	585	535	Ø 20	120	42	345	675	775	4	125	470	280	10-16	10-16	
NCDS2P100-250	125	100	75	280S	734	1052	1564	1379	130	250	879	695	645	Ø 20	140	42	420	810	950	4	140	470	280	10-16	10-16	

BGAD = Base and coupling
 * = Indicatives values according to the type of motor installed.

BGAD = Рама и муфта
 * = Приблизит. значения в завис. от марки двигателя.

BGAD = Base e giunto
 * = Valori indicativi in funzione della marca di motore utilizzato.

o Motor in IE4 efficiency class according to EU REGULATION 2019/1781. Available in other efficiency classes for non-EU markets.

o Двигатель класса эффективности IE4 в соответствии с РЕГЛАМЕНТОМ UE2019/1781. Имеются варианты других классов эффективности для рынков за пределами ЕС.

o Motore in classe di efficienza IE4 in conformità al REGOLAMENTO UE2019/1781. Disponibili in altre classi di efficienza per mercati extra UE.

Selection - dimensions and weights for base mounted electric pumps
 Подбор - габариты и вес электронасосов на раме
 Selezione - dimensioni e pesi elettropompe su base

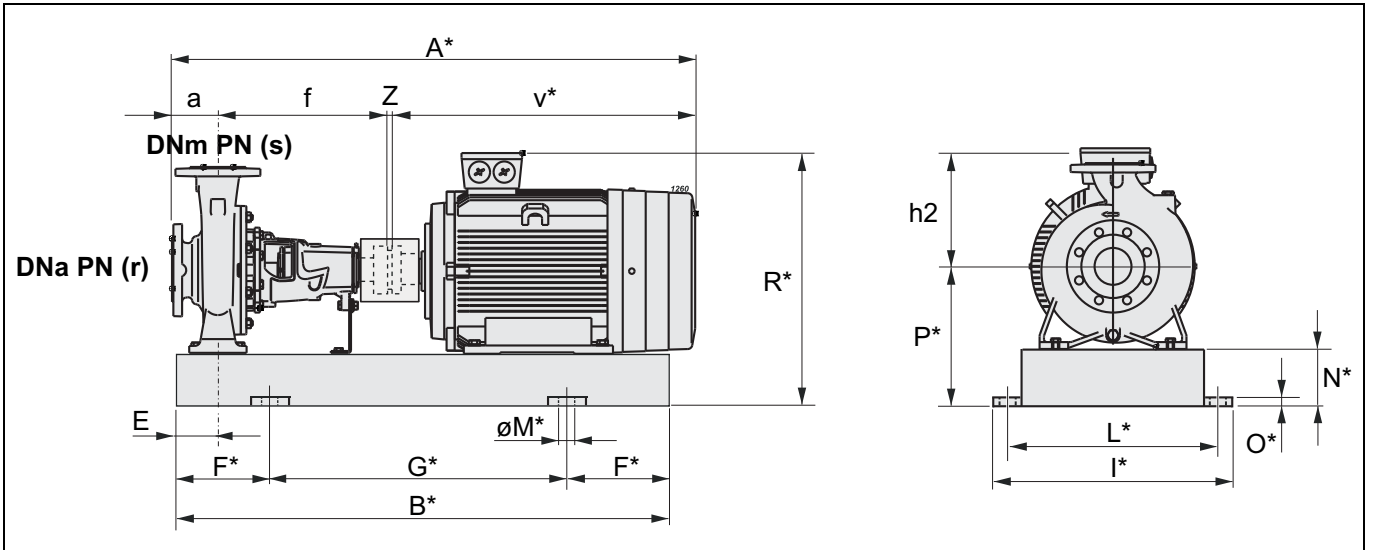

Pump Насос Pompa		Motor Двигатель Motore		Weight Вес Peso	BGAD	A *	B *	E	F *	G *	I *	L *	M *	N *	O *	P *	R *	V *	Z	a	f	h2	r	s
Type Тип	DNa DNm [mm]	[kW]	Size Размер Grand.	[kg]	Type Тип	[mm]																		
NCD4P32-200	50 32	0,75	80	79	1011	739	649	60	100	449	370	320	∅ 16	80	38	240	365	295	4	80	360	180	10-16	10-16
NCD4P40-160	65 40	0,75	80	24305	1016	739	659	60	100	459	370	320	∅ 16	65	38	197	322	295	4	80	360	160	10-16	10-16
NCD4P40-200	65 40	1,1	90S	85	1020	819	665	60	100	465	395	345	∅ 16	80	38	240	378	355	4	100	360	180	10-16	10-16
NCD4P40-250	65 40	3	100L	131	1023	869	737	72,5	100	537	450	400	∅ 20	100	42	280	430	405	4	100	360	225	10-16	10-16
NCD4P50-125	65 50	0,75	80	24306	1016	759	659	60	100	459	370	320	∅ 16	65	38	197	322	295	4	100	360	160	10-16	10-16
NCD4P50-160	65 50	1,1	90S	78	1020	819	665	60	100	465	395	345	∅ 16	80	38	240	378	355	4	100	360	180	10-16	10-16
NCD4P50-200	65 50	2,2	100L	105	1009	869	724,5	60	100	524,5	395	345	∅ 16	80	38	240	390	405	4	100	360	200	10-16	10-16
NCD4P50-250	65 50	4	112M	129	1025	904	744,5	72,5	100	544,5	450	400	∅ 20	100	42	280	452	440	4	100	360	225	10-16	10-16
NCD4P65-125	80 65	1,1	90S	84	1081	819	677,5	72,5	100	477,5	410	360	∅ 16	80	38	240	378	355	4	100	360	180	10-16	10-16
NCD4P65-160	80 65	1,5	90L	91	1082	849	702,5	72,5	100	502,5	410	360	∅ 16	80	38	240	378	385	4	100	360	200	10-16	10-16
NCD4P65-200	80 65	3	100L	124	1023	869	737	72,5	100	537	450	400	∅ 20	100	42	280	430	405	4	100	360	225	10-16	10-16
NCD4P65-250	80 65	5,5	132S	182	1032	1029	913	90	150	613	490	440	∅ 20	100	42	300	492	455	4	100	470	250	10-16	10-16
NCD4P65-315	80 65	11	160M	329	1034	1226	1047	90	150	747	530	480	∅ 20	120	42	345	596	627	4	125	470	280	10-16	10-16
NCD4P80-160	100 80	2,2	100L	120	1023	894	737	72,5	100	537	450	400	∅ 20	100	42	280	430	405	4	125	360	225	10-16	10-16
NCD4P80-200	100 80	4	112M	161	1039	1039	854,5	72,5	150	554,5	475	425	∅ 20	100	42	280	452	440	4	125	470	250	10-16	10-16
NCD4P80-250	100 80	7,5	132M	198	1085	1089	951	90	150	651	530	480	∅ 20	100	42	300	492	490	4	125	470	280	10-16	10-16
NCD4P80-315	100 80	15	160L	328	1072	1226	1091	90	200	691	530	480	∅ 20	120	42	370	621	627	4	125	470	315	10-16	10-16
NCD4P80-400	100 80	30	200L	565	1046	1417	1262	95	200	862	565	515	∅ 20	140	42	420	720	758	4	125	530	355	10-16	10-16
NCD4P100-200	125 100	5,5	132S	176	1032	1054	913	90	150	613	490	440	∅ 20	100	42	300	492	455	4	125	470	280	10-16	10-16
NCD4P100-250	125 100	11	160M	301	1034	1241	1047	90	150	747	530	480	∅ 20	120	42	345	596	627	4	140	470	280	10-16	10-16
NCD4P100-315	125 100	18,5	180M	393	1044	1279	1101	90	200	701	530	480	∅ 20	120	42	370	640	665	4	140	470	315	10-16	10-16
NCD4P100-400	125 100	37	225S	643	1055	1467	1275	110	200	875	630	580	∅ 20	140	42	420	750	793	4	140	530	355	10-16	10-16
NCD4P125-250	150 125	15	160L	325	1072	1241	1091	90	200	691	530	480	∅ 20	120	42	370	621	627	4	140	470	355	10-16	10-16
NCD4P125-315	150 125	30	200L	549	1054	1432	1254	110	200	854	630	580	∅ 20	140	42	420	720	758	4	140	530	355	10-16	10-16
NCD4P125-400	150 125	55	250M	861	1058	1554	1362	110	250	862	630	580	∅ 22	160	50	475	850	880	4	140	530	400	10-16	10-16
NCD4P150-315	200 150	37	225S	653	1061	1487	1275	110	200	875	680	630	∅ 20	140	42	420	750	793	4	160	530	400	10	10-16
NCD4P150-400	200 150	75	280S	1002	1064	1707	1409	110	250	909	680	630	∅ 22	160	50	475	870	1013	4	160	530	450	10	10-16
NCD4P200-315	250 200	75	280S	-	1090	1827	1582	140	300	982	760	710	∅ 22	180	50	535	930	1013	4	180	630	450	16	16
NCD4P200-400	250 200	132	315M	1630	1068	2135	1807	130	300	1207	780	730	∅ 22	180	50	535	1090	1321	4	180	630	500	16	16

BGAD = Base and coupling
 * = Indicatives values according to the type of motor installed.

BGAD = Рама и муфта
 * = Приблизит. значения в завис. от марки двигателя.

BGAD = Base e giunto
 * = Valori indicativi in funzione della marca di motore utilizzato.

○ Motor in IE4 efficiency class according to EU REGULATI ON 2019/1781. Available in other efficiency classes for non-EU markets.

○ Двигатель класса эффективности IE4 в соответствии с РЕГЛАМЕНТОМ UE2019/1781. Имеются варианты других классов эффективности для рынков за пределами ЕС.

○ Motore in classe di efficienza IE4 in conformità al REGOLAMENTO UE2019/1781. Disponibili in altre classi di efficienza per mercati extra UE.

Selection - dimensions and weights for base mounted electric pumps
 Подбор - габариты и вес электронасосов на раме
 Selezione - dimensioni e pesi elettropompe su base

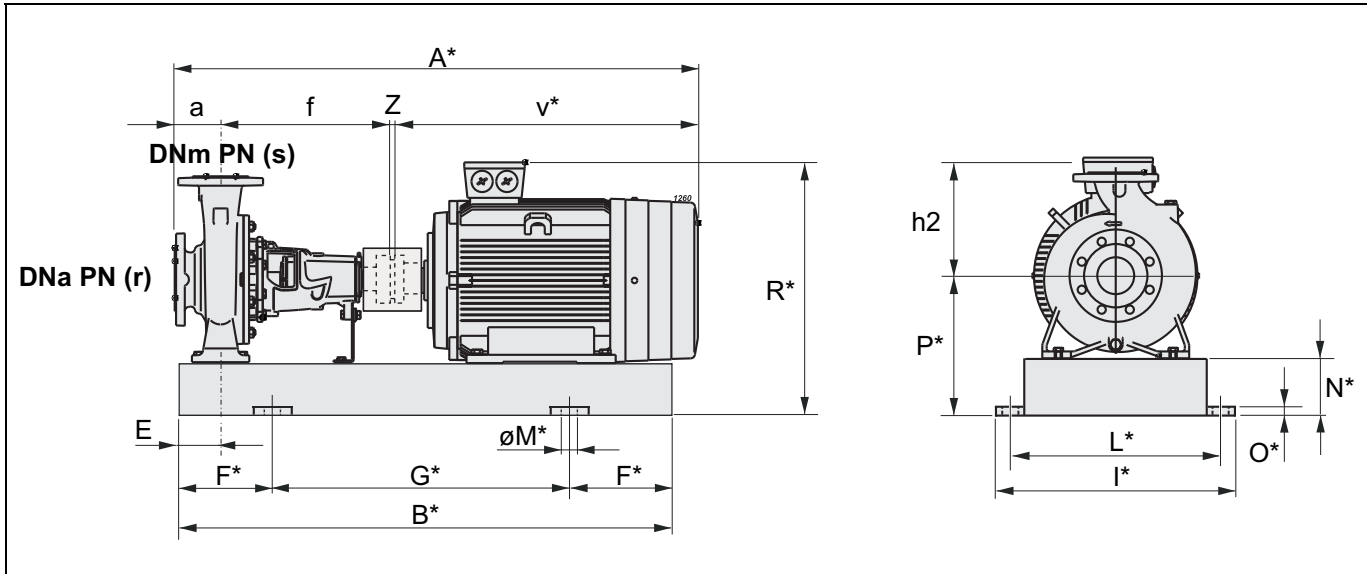

Pump Насос Помпа		Motor Двигатель Motore		Weight Вес Peso	BGAD	A*	B*	E	F*	G*	I*	L*	M*	N*	O*	P*	R*	V*	Z	a	f	h2	r	s					
Type Тип Tipo	DNa [mm]	DNm [mm]	[kW]	Size Размер Grand.	[kg]	Type Тип Tipo	[mm]																						
NCDS4P32-200	50	32	0,75	80	80	1011	739	649	60	100	449	370	320	ø 16	80	38	240	365	295	4	80	360	180	10-16	10-16				
NCDS4P40-160	65	40	0,75	80	24305	1016	739	659	60	100	459	370	320	ø 16	65	38	197	322	295	4	80	360	160	10-16	10-16				
NCDS4P40-200	65	40	1,1	90S	85	1020	819	665	60	100	465	395	345	ø 16	80	38	240	378	355	4	100	360	180	10-16	10-16				
NCDS4P40-250	65	40	3	100L	131	1023	869	737	72,5	100	537	450	400	ø 20	100	42	280	430	405	4	100	360	225	10-16	10-16				
NCDS4P50-160	65	50	1,1	90S	78	1020	819	665	60	100	465	395	345	ø 16	80	38	240	378	355	4	100	360	180	10-16	10-16				
NCDS4P50-200	65	50	2,2	100L	105	1009	869	724,5	60	100	524,5	395	345	ø 16	80	38	240	390	405	4	100	360	200	10-16	10-16				
NCDS4P50-250	65	50	4	112M	127	1025	904	744,5	72,5	100	544,5	450	400	ø 20	100	42	280	452	440	4	100	360	225	10-16	10-16				
NCDS4P65-125	80	65	1,1	90S	84	1081	819	677,5	72,5	100	477,5	410	360	ø 16	80	38	240	378	355	4	100	360	180	10-16	10-16				
NCDS4P65-160	80	65	1,5	90L	91	1082	849	702,5	72,5	100	502,5	410	360	ø 16	80	38	240	378	385	4	100	360	200	10-16	10-16				
NCDS4P65-200	80	65	3	100L	124	1023	869	737	72,5	100	537	450	400	ø 20	100	42	280	430	405	4	100	360	225	10-16	10-16				
NCDS4P65-250	80	65	5,5	132S	182	1032	1029	913	90	150	613	490	440	ø 20	100	42	300	492	455	4	100	470	250	10-16	10-16				
NCDS4P65-315	80	65	11	160M	327	1034	1226	1047	90	150	747	530	480	ø 20	120	42	345	596	627	4	125	470	280	10-16	10-16				
NCDS4P80-160	100	80	2,2	100L	120	1023	894	737	72,5	100	537	450	400	ø 20	100	42	280	430	405	4	125	360	225	10-16	10-16				
NCDS4P80-200	100	80	4	112M	161	1039	1039	854,5	72,5	150	554,5	475	425	ø 20	100	42	280	452	440	4	125	470	250	10-16	10-16				
NCDS4P80-250	100	80	7,5	132M	197	1085	1089	951	90	150	651	530	480	ø 20	100	42	300	492	490	4	125	470	280	10-16	10-16				
NCDS4P80-315	100	80	15	160L	328	1072	1226	1091	90	200	691	530	480	ø 20	120	42	370	621	627	4	125	470	315	10-16	10-16				
NCDS4P80-400	100	80	30	200L	565	1046	1417	1262	95	200	862	565	515	ø 20	140	42	420	720	758	4	125	530	355	10-16	10-16				
NCDS4P100-200	125	100	5,5	132S	176	1032	1054	913	90	150	613	490	440	ø 20	100	42	300	492	455	4	125	470	280	10-16	10-16				
NCDS4P100-250	125	100	11	160M	301	1034	1241	1047	90	150	747	530	480	ø 20	120	42	345	596	627	4	140	470	280	10-16	10-16				
NCDS4P100-315	125	100	18,5	180M	390	1044	1279	1101	90	200	701	530	480	ø 20	120	42	370	640	665	4	140	470	315	10-16	10-16				
NCDS4P100-400	125	100	37	225S	641	1055	1467	1275	110	200	875	630	580	ø 20	140	42	420	750	793	4	140	530	355	10-16	10-16				
NCDS4P125-250	150	125	15	160L	322	1072	1241	1091	90	200	691	530	480	ø 20	120	42	370	621	627	4	140	470	355	10-16	10-16				
NCDS4P125-315	150	125	30	200L	546	1054	1432	1254	110	200	854	630	580	ø 20	140	42	420	720	758	4	140	530	355	10-16	10-16				
NCDS4P125-400	150	125	55	250M	861	1058	1554	1362	110	250	862	630	580	ø 22	160	50	475	850	880	4	140	530	400	10-16	10-16				
NCDS4P150-315	200	150	37	225S	653	1061	1487	1275	110	200	875	680	630	ø 20	140	42	420	750	793	4	160	530	400	10	10-16				
NCDS4P150-400	200	150	75	280S	898	1064	1714	1409	110	250	909	680	630	ø 22	160	50	475	865	1020	4	160	530	450	10	10-16				
NCDS4P200-315	250	200	75	280S	-	1090	1834	1582	140	300	982	760	710	ø 22	180	50	535	925	1020	4	180	630	450	16	16				
NCDS4P200-400	250	200	132	315M	1515	1068	2137	1807	130	300	1207	780	730	ø 22	180	50	535	1090	1323	4	180	630	500	16	16				

BGAD = Base and coupling
 * = Indicatives values according to the type of motor installed.

BGAD = Рама и муфта
 * = Приблизит. значения в завис. от марки двигателя.

BGAD = Base e giunto
 * = Valori indicativi in funzione della marca di motore utilizzato.

o Motor in IE4 efficiency class according to EU REGULATION 2019/1781. Available in other efficiency classes for non-EU markets.

o Двигатель класса эффективности IE4 в соответствии с РЕГЛАМЕНТОМ UE2019/1781. Имеются варианты других классов эффективности для рынков за пределами ЕС.

o Motore in classe di efficienza IE4 in conformità al REGOLAMENTO UE2019/1781. Disponibili in altre classi di efficienza per mercati extra UE.

Flanges (UNI EN 1092-2)
 Фланцы (UNI EN 1092-2)
 Flange (UNI EN 1092-2)

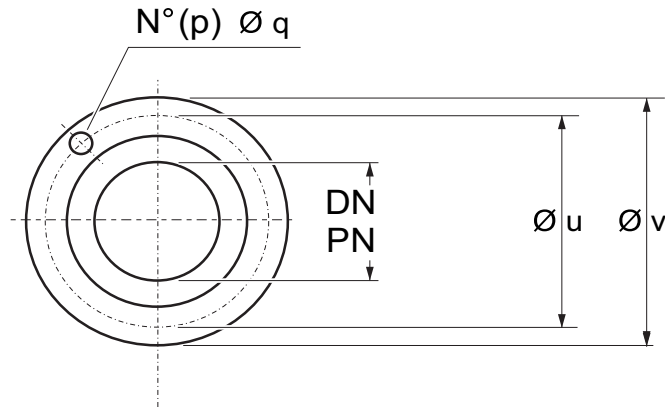

Port \varnothing \varnothing отверстия \varnothing Восса		Holes Отверстия Fori		$\varnothing u$	$\varnothing v$
DN [mm]	PN [bar]	p No	q \varnothing [mm]	[mm]	
32	10/16	4	19	100	140
40	10/16	4	19	110	150
50	10/16	4	19	125	165
65	10/16	4	19	145	185
80	10/16	8	19	160	200
100	10/16	8	19	180	220
125	10/16	8	19	210	250
150	10/16	8	23	240	285
200	10	8	23	295	340
200	10	12	23	295	340
200	16	12	23	295	340
250	16	12	28	355	405

caprari

The dimensions have an indicative value. Executive drawing will be supplied on request upon order.
CAPRARI S.p.A. reserves the right to make changes to improve its products at any time and without any notice

Размеры являются ориентировочными. Чертеж будет предоставлен по запросу при заказе. CAPRARI S.p.A. оставляет за собой право вносить изменения с целью улучшения своих продуктов в любое время и без предварительного уведомления.

Le dimensioni hanno valore indicativo. Il disegno esecutivo sarà fornito su richiesta in fase d'ordine.
CAPRARI S.p.A. si riserva facoltà di apportare modifiche atte a migliorare i propri prodotti in qualsiasi momento e senza preavviso alcuno.